

**CONSOLIDATED TO 30 JUNE 2012**

**LAWS OF SEYCHELLES**

**CIVIL AVIATION ACT**

Act 4 of 2005  
S.I. 7 of 2007

*[1st April, 2005]*

**ARRANGEMENT OF SECTIONS**

**Part I - Preliminary**

1. Short title and commencement
2. Interpretation

**Part II - Regulation of Civil Aviation**

3. Power to give effect to Chicago Convention etc and regulate air navigation
4. Mortgaging of aircraft registered in Seychelles
5. Control of aviation in time of war or emergency
6. Investigation of air accidents
7. Dangerous flying
8. Licensing of air transport and commercial flying
9. Information as to air transport undertakings and use of customs aerodromes

**Part III - Aerodromes and Other Land**

10. Indication of presence of obstructions near aerodromes
11. Trespassing on aerodromes

**Part IV - Liability for damage, etc. caused by aircraft**

12. Liability of aircraft in respect of trespass, nuisance and surface damage
13. Nuisance caused by aircraft on aerodromes

**Part V - Miscellaneous**

14. Detention and sale of aircraft for unpaid aircraft charges or air navigation charges
15. Application of law of wreck and salvage to aircraft
16. Exemption of aircraft and parts thereof from seizure on patent claims

**Part VI - Supplemental**

17. Orders and regulations
18. Detention of aircraft
19. Extraterritorial effect
20. Offences under the Act
21. Application of criminal law to aircraft
22. Savings

## **Part VII - General**

23. Payment of fines
24. Transitional
25. Repeal

---

1. This Act may be cited as the Civil Aviation Act.

2. In this Act —

“aerodrome” means any area of land or water designed, equipped, set apart or commonly used for affording facilities for the landing and departure of aircraft and includes any area or space, whether on the ground, on the roof of a building or elsewhere, which is designed, equipped or set apart for affording facilities for the landing and departure of aircraft capable of descending or climbing vertically;

“Chicago Convention” means the Convention on International Civil Aviation done at Chicago on the seventh day of December 1944 as amended by any subsequent convention or agreement;

“Government aerodrome” means an aerodrome under the control of the Seychelles Civil Aviation Authority, and a naval, military or air force aerodrome;

“land” includes any estate or other interest in land and easement.

(2) Any reference in this Act to the carrying out of works on land shall be construed as including a reference to the making of excavations on the land or the carrying out of levelling operations, on the land, and references to the maintenance of works or to interference with works shall be construed accordingly.

(3) For the avoidance of doubt it is hereby declared that in this Act the expression “loss or damage” includes, in relation to persons, loss of life and personal injury.

(4) Any reference in this Act to goods or articles shall be construed as including a reference to mails or animals.

(5) Any reference in this Act to the Republic shall, unless the context otherwise requires, be construed as including a reference to the territorial waters adjacent to the Republic.

(6) Any power conferred by this Act shall be in addition to and not in derogation of any other power so conferred.

## **Part II - Regulation of Civil Aviation**

**3.** (1) The Minister may, by regulations, make such provision as appears to him to be requisite or expedient —

- (a) for carrying out the Chicago Convention, any Annex thereto relating to international standards and recommended practices (being an Annex adopted in accordance with the Convention) and any amendment of the Convention or any such Annex made in accordance with the Convention; or
- (b) for carrying out any other international agreement relating to aviation; or
- (c) generally for regulating air navigation.

(2) The Minister may, by regulations, make provision —

- (a) as to the registration of aircraft in the Republic;
- (b) for prohibiting aircraft from flying unless certificates of airworthiness issued, or validated under the regulations are in force with respect to them and except upon compliance with such conditions as to maintenance or repair as may be specified in the regulations;
- (c) for the licensing, inspection and regulation of aerodromes, for access to aerodromes and places where aircraft have landed, for access to aircraft factories for the purpose of inspecting work therein carried on in relation to aircraft or parts thereof and for prohibiting or regulating the use of unlicensed aerodromes;
- (d) for prohibiting persons from engaging in, or being employed in or (except in the maintenance at unlicensed aerodromes of aircraft not used for or in connection with commercial, industrial or other gainful purposes) in connection with, air navigation in such capacities as may be specified in the regulations except in accordance with

provisions in that behalf contained in the regulations, and for the licensing of those employed at aerodromes licensed under the regulations in the inspection or supervision of aircraft;

- (e) as to the conditions under which, and in particular the aerodromes to or from which, aircraft entering or leaving the Republic may fly, and as to the conditions under which aircraft may fly from one part of the Republic to another;
- (f) as to the conditions under which passengers and goods may be carried by air and under which aircraft may be used for other commercial, industrial or gainful purposes, and for prohibiting the carriage by air of goods of such classes as may be specified in the regulations;
- (g) for minimising or preventing interference with the use or effectiveness of apparatus used in connection with air navigation, and for prohibiting or regulating the use of such apparatus as aforesaid and the display of signs and lights liable to endanger aircraft;
- (h) generally for securing the safety, efficiency and regularity of air navigation and the safety of aircraft and of persons and property carried therein, for preventing aircraft endangering other persons and property and, in particular, for the detention of aircraft for any of the purposes specified in this paragraph;
- (i) for requiring persons engaged in, or employed in or in connection with, air navigation to supply meteorological information for the purposes of air navigation;
- (j) for regulating the making of signals and other communications by or to aircraft and persons carried therein;
- (k) for regulating the use of the civil air ensign and any other ensign established by the Minister for purposes connected with air navigation;
- (l) for prohibiting aircraft from flying over such areas in the Republic as may be specified in the regulations;
- (m) for applying, adapting or modifying, or enabling the Minister responsible for finance to apply, adapt or modify, the enactments relating to customs in relation to aerodromes and to aircraft and to persons and property carried therein and for preventing smuggling by air, and for permitting, or enabling the Minister responsible for finance to permit, in connection with air navigation, subject to such

conditions as appear to the Minister responsible for finance to be requisite or expedient for the protection of the revenue or the importation of goods into the Republic without payment of duty;

- (n) as to the manner and conditions of the issue, validation, renewal, extension or variation of any certificate, licence or other document required by the regulations (including the examinations and tests to be undergone), and as to the form, custody, production, cancellation, suspension, endorsement and surrender of any such documents;
- (o) for regulating, or enabling the Minister after consultation with the Minister responsible for finance to regulate, the charges that may be made for the use of aerodromes licensed under the regulations and for services provided at aerodromes;
- (p) for prescribing, or enabling the Minister after consultation with the Minister responsible for finance to prescribe, the fees to be paid in respect of the issue, validation, renewal, extension or variation of any certificate, licence or other document or the undergoing of any examination or test required by, or in pursuance of, the regulations and in respect of any other matters in respect of which it appears to the Minister after consultation with the Minister responsible for finance to be expedient for the purpose of the regulations to charge fees;
- (q) for exempting from the provisions of the regulations or any of them any aircraft or persons or classes of aircraft or persons;
- (r) for prohibiting aircraft from taking off or landing in the Republic unless there are in force in respect of those aircraft such certificates of compliance with standards as to noise as may be specified in the regulations and except upon compliance with the conditions of those certificates.

(3) Regulations under this section may make different provision with respect to different classes of aircraft, aerodromes, persons or property and with respect to different circumstances and with respect to different parts of the Republic but shall, so far as practicable, be so framed as not to discriminate in like circumstances between aircraft registered in the Republic operated on charter terms by one air transport undertaking and such aircraft so operated by another such undertaking.

(4) Regulations under this section may, for the purpose of securing compliance with the provisions thereof, provide for the imposition of penalties not exceeding a fine of R200,000 and imprisonment for a term not exceeding two years and, in the case of any provision having effect by virtue of paragraph (1) of subsection

(2) of this section, may also for that purpose provide for the taking of such steps (including firing on aircraft) as may be specified in the regulations.

4. (1) The Minister may, by regulations, make provision for the mortgaging of aircraft registered in Seychelles.

(2) Regulations made under this section may —

- (a) make provision for a register of mortgages;
- (b) make provision as respects the rights and liabilities of mortgagors and mortgagees of aircraft and as respects the priority inter se of such rights and the relationship of such rights to other rights in or over such aircraft;
- (c) make provision specifying the fees to be paid in respect of the making or deletion of entries in the register of mortgages, of the inspection of the register and of making copies thereof;
- (d) make provision for the imposition of penalties not exceeding 5 years' imprisonment and fine of R100,000 in respect of making of false statements in connection with matters relating to mortgages of aircraft and in respect of the forgery of documents relating to such matters.

5. (1) In time of war, whether actual or imminent, or of great national emergency, the Minister may by Order regulate or prohibit, either absolutely or subject to such conditions as may be contained in the Order, the navigation of all or any descriptions of aircraft over the Republic or any portion thereof, and may by Order provide for taking possession of the using for the purposes of the naval, military or air forces of the Republic any aerodrome, or any aircraft in the Republic, or any machinery, plant, material or things found in or on any such aerodrome or such aircraft, and for regulating or prohibiting the use, erection, building, maintenance or establishment of any aerodrome, or flying school, or any class or description thereof.

(2) An Order under this section may make, for the purposes of the Order, such provision as Regulations under section 3 of this Act may by virtue of subsection (4) of that section make for the purpose of securing compliance with provisions thereof having effect by virtue of paragraph (1) of subsection (2) of that section.

(3) Any person who suffers direct injury or loss owing to the operation of an Order of the Minister under this section shall be entitled to receive compensation from the Minister from such public funds as he may lawfully apply for the purpose, the amount thereof to be fixed, in default of agreement, by an arbitrator to be agreed upon or failing agreement to be appointed by the Chief Justice:

Provided that no compensation shall be payable by reason of the operation of a general Order under this section prohibiting flying in the Republic or any part thereof.

6. (1) The Minister may make regulations providing for the investigation of any accident arising out of or in the course of air navigation and either occurring in or over the Republic or occurring elsewhere to aircraft registered in the Republic.

(2) Regulations under this section may contain provisions—

- (a) requiring notice to be given of any such accident as aforesaid in such manner and by such persons as may be specified;
- (b) applying, with or without modification, for the purpose of investigations held with respect to any such accidents any of the provisions of any law in force in the Republic relating to the investigation of deaths or accidents;
- (c) prohibiting, pending investigation, access to or interference with aircraft to which an accident has occurred, and authorising any person, so far as may be necessary for the purposes of an investigation, to have access to, examine, remove, take measures for the preservation of, or otherwise deal with, any such aircraft;
- (d) authorising or requiring the cancellation, suspension, endorsement or surrender of any licence or certificate granted in the Republic under this Act or any Regulation or Order made under this Act, or the withdrawal or suspension of any validation conferred in the Republic of a licence granted by a competent authority elsewhere, where it appears on an investigation that the licence or certificate ought to be cancelled, suspended, endorsed or surrendered, or the validation withdrawn or suspended as the case may be, and requiring the production of any such licence or certificate for the purpose of being so dealt with:

Provided that nothing in this section shall limit the powers of any authority under any law relating to merchant shipping.

(3) If any person contravenes or fails to comply with any regulation under this section, he shall be liable, on conviction, to a fine not exceeding R100,000 or to imprisonment for a term not exceeding 1 year.

7. (1) Where an aircraft is flown in such a manner as to be the cause of unnecessary danger to any person or property on land or water, the pilot or the person in charge of the aircraft, and also the owner thereof unless he proves to the satisfaction of the court that the aircraft was so flown without his actual fault or privity, shall be liable

on conviction to a fine not exceeding R200,000 or to imprisonment for a term not exceeding 2 years or to both such fine and such imprisonment.

In this section, the expression “owner” in relation to an aircraft includes any person by whom the aircraft is hired at the time of the offence.

(2) The provisions of this section shall be in addition to and not in derogation of the powers conferred on the Minister by section 3 of this Act.

**8.** (1) The Minister may make regulations —

- (a) to secure that aircraft shall not be used in the Republic by any person —
  - (i) for plying, while carrying passengers or goods for hire or reward, on such journeys or classes of journeys (whether beginning and ending at the same point or at different points) as may be specified in the regulations; or
  - (ii) for such flying undertaken for the purpose of any trade or business as may be so specified, except under the authority of, and in accordance with, a licence granted to the said person by the licensing authority specified in the regulations;
- (b) as to the circumstances in which a licence under the regulations may or shall be granted, refused, revoked or suspended, and in particular as to the matters to which the licensing authority specified in the regulations is to have regard in deciding whether to grant or refuse such a licence;
- (c) as to appeals from the licensing authority by persons interested in the grant, refusal, revocation or suspension of any licence under the regulations;
- (d) as to the conditions which may be attached to such a licence (including conditions as to the fares, freight or other charges to be charged by the holder of the licence), and for securing compliance with any conditions so attached;
- (e) as to the information to be furnished by an applicant for, or the holder of, such a licence to such authorities as may be specified in the regulations;
- (f) prescribing the fees to be paid in respect of the grant of any licence under the regulations, or enabling such fees to be prescribed by any person or authority specified in that behalf by the regulations,



and such regulations may make different provision as respects different classes of aircraft and different classes of licences.

(2) Regulations made under this section may, for the purpose of securing compliance with the regulations, provide for the imposition of the following penalties, namely —

- (a) in the case of a first offence against the regulations, a fine not exceeding R200,000 or imprisonment for a term not exceeding 2 years or both such fine and such imprisonment; and
- (b) in the case of a second or subsequent offence against the regulations, a fine not exceeding R1,000,000 or imprisonment for a term not exceeding 5 years or both such fine and such imprisonment.

9. (1) The Minister may make regulations —

- (a) requiring any person —
  - (i) who carries on the business of carrying passengers or goods in aircraft for hire or reward on such journeys (whether beginning and ending at the same point or at different points) as may be specified in the regulations; or
  - (ii) who is the holder of a licence in respect of a customs aerodrome,

to furnish to such authorities as may be specified in the regulations such information relating to the use of aircraft for the purpose of his said business and to the persons employed in connection with that use, or, as the case may be, relating to the use of the aerodrome and to the persons employed in aircraft arriving thereat or departing therefrom, as may be prescribed by the regulations;

- (b) requiring the owner, or the pilot or other person in charge of any aircraft arriving at, or departing from, any customs aerodrome to furnish to the holder of the licence in respect of that aerodrome such information as may be necessary to enable the holder of the said licence to comply with such of the provisions of the regulations as relate to him;
- (c) prescribing the times at which, and the form and manner in which, any information required under the regulations is to be furnished:

Provided that a person carrying on such a business as is mentioned in subparagraph (i) of paragraph (a) of this subsection shall not be required to furnish information relating to the use of aircraft on journeys wholly outside the Republic unless the person carrying on the business is either a citizen of the Republic or a body corporate incorporated under the law of the Republic.

(2) Regulations under this section may provide for imposing on any person who contravenes or fails to comply with any provision of the regulations such penalties (not exceeding a fine of R100,000 and a further fine of R25,000 for every day on which the contravention or non-compliance continues after conviction therefor) as may be specified in the regulations.

(3) No information with respect to any particular undertaking which has been obtained by virtue of regulations under this section shall, without the consent of the person carrying on that undertaking, be disclosed otherwise than in connection with the execution of such regulations, and if any person discloses any such information in contravention of this subsection, he shall be liable on conviction to imprisonment for a term not exceeding 1 year or to a fine not exceeding R100,000 or to both such fine and such imprisonment.

Nothing in this subsection shall apply to the disclosure of any information for the purposes of any legal proceedings which may be taken by virtue of this subsection or regulations made under this section or for the purpose of any report of any such proceedings, but, save as aforesaid, the restriction imposed by this subsection shall, in relation to any legal proceedings (including arbitration), extend so as to prohibit and prevent any person who is in possession of any such information so obtained from disclosing, and from being required by any court or arbitrator to disclose, that information (whether as a witness or otherwise) except with the consent of the person carrying on the undertaking to which the information relates.

(4) In this section, the expression “customs aerodrome” means an aerodrome for the time being appointed as a place of landing or departure of aircraft for the purposes of the enactments relating to customs.

### **Part III - Aerodromes and Other Land**

**10.** (1) If the Minister is satisfied, with respect to any building, structure or erection in the vicinity of any aerodrome to which this section applies that, in order to avoid danger to aircraft flying in that vicinity in darkness or conditions of poor visibility, provision ought to be made (whether by lighting or otherwise) for giving to such aircraft warning of the presence of that building, structure or erection, he may by order in writing authorise (subject to any conditions specified in the order) the proprietor of the aerodrome, and any person acting under the proprietor's instruction —

- (a) to execute, install, maintain, operate, and, as occasion requires, to repair and alter, such works and apparatus as may be necessary for

enabling such warning to be given in the manner specified in the order; and

- (b) so far as may be necessary for exercising any of the powers conferred by the order to enter upon and pass over (with or without vehicles) any such land as may be specified in the order:

Provided that no such order shall be made in relation to any building, structure or erection if it appears to the Minister that there have been made, and are being carried out, satisfactory arrangements for the giving of such warning as aforesaid of the presence of the building, structure or erection.

(2) The Minister shall, before making any such order as aforesaid cause to be published, in such manner as he thinks best for informing persons concerned, notice of the proposal to make the order and of the place where copies of the draft order may be obtained free of charge, and take into consideration any representations with respect to the order which may, within such period not being less than two months after the publication of the notice as may be specified therein, be made to him by any person appearing to him to have an interest in any land which would be affected by the order; and at the end of that period the order may, subject to the provisions of this section, be made with such modification (if any) of the original draft as the Minister thinks proper.

(3) Every such order as aforesaid shall provide —

- (a) that, except in a case of emergency, no works shall be executed on any land in pursuance of the order unless, at least fourteen days previously, the proprietor of the aerodrome to which the order relates has served in the manner prescribed by the order on the occupier of that land, and on every other person known by the proprietor to have an interest therein, a written notice containing such particulars of the nature of the proposed works, and the manner in which and the time at which it is proposed to execute them, as may be prescribed by or in accordance with the order; and
- (b) that if, within fourteen days after service of the said notice on any person having such an interest, the proprietor of the aerodrome receives a written intimation of objection on the part of that person to the proposals contained in the notice, being an intimation which specifies the grounds of objection, then, unless and except in so far as the objection is withdrawn, no step shall be taken in pursuance of the notice without the specific sanction of the Minister, and shall also provide for requiring the proprietor of the aerodrome to which the order relates to pay to any person having an interest in any land affected by the order such compensation for any loss or damage which that person may suffer in consequence of the order as may, in default of agreement, be determined from time to time by a single

arbitrator appointed by the Chief Justice and, for the purposes of this subsection, any expense reasonably incurred in connection with the lawful removal of any apparatus installed in pursuance of such an order, and so much of any expense incurred in connection with the repair, alteration, demolition or removal of any building, structure or erection to which such an order relates as is attributable to the operation of the order, shall be deemed to be loss or damage suffered in consequence of the order.

(4) The ownership of anything shall not be taken to be affected by reason only that it is placed in, or affixed to, any land in pursuance of such an order as aforesaid; and (subject, to the provisions of the next following subsection) so long as any such order in respect of an aerodrome is in force, no person shall, except with the consent of the proprietor of the aerodrome, willfully interfere with any works or things which, to the knowledge of that person, are works or things executed or placed, in, on or over any land in pursuance of the order.

If any person contravenes the foregoing provisions of this subsection, he shall be liable, on conviction, to imprisonment for a term not exceeding 1 year or to a fine not exceeding R100,000 or to both such fine and such imprisonment; and every person who wilfully obstructs a person in the exercise of any of the powers conferred by such an order as aforesaid shall be liable on conviction to a fine not exceeding R50,000.

(5) Nothing in this section shall operate, in relation to any building, structure or erection, so as to restrict the doing of any work for the purpose of repairing, altering, demolishing or removing the building, structure or erection:

Provided that —

- (a) notice of the doing of that work is given as soon as may be to the proprietor of that aerodrome; and
- (b) the giving of warning of the presence of the building, structure or erection in the manner provided by any order under this section in force in relation thereto is not interrupted.

(6) In this section —

- (a) the expression “aerodrome to which this section applies” means a Government aerodrome or any premises which, by virtue of regulations made under section 3 of this Act, are for the time being licensed as an aerodrome for public use; and
- (b) the expression “proprietor of the aerodrome” means, in relation to any premises used or appropriated for use as an aerodrome, the person carrying on or entitled to carry on the business of an

aerodrome in those premises or, in the case of a Government aerodrome, the officer in charge of the aerodrome.

**11.** If any person trespasses on any land forming part of a Government aerodrome or an aerodrome licensed in pursuance of regulations under section 3 of this Act, he shall be liable on conviction to a fine not exceeding R25,000:

Provided that no person shall be liable to any penalty under this section unless it is proved that, at the material time, notices warning trespassers of their liability under this section were posted so as to be readily seen and read by members of the public in such positions on or near the boundary of the aerodrome as appear to the court to be proper.

#### **Part IV - Liability for damage, etc., caused by aircraft**

**12.** (1) No action shall lie in respect of trespass or in respect of nuisance, by reason only of the flight of an aircraft over any property at a height above the ground, which, having regard to wind, weather and all the circumstances of the case, is reasonable, or the ordinary incidents of such flight so long as the provisions of Part II and this Part of this Act and any regulations or order made thereunder being provisions which extend to the Republic, are duly complied with.

(2) Where material loss or damage is caused to any person or property on land or water by, or by a person in, or an article or person falling from, an aircraft while in flight, taking off or landing, then unless the loss or damage was caused or contributed to by the negligence of the person by whom it was suffered, damages in respect of the loss or damage shall be recoverable without proof of negligence or intention or other cause of action, as if the loss or damage had been caused by the wilful act, neglect or default of the owner of the aircraft:

Provided that where material loss or damage is caused as aforesaid in circumstances in which —

- (a) damages are recoverable in respect of the said loss or damage by virtue only of the foregoing provisions of this subsection, and
- (b) a legal liability is created in some person other than the owner to pay damages in respect of the said loss or damage, the owner shall be entitled to be indemnified by that other person against any claim in respect of the said loss or damage.

**13.** (1) Regulations under section 3 of this Act may provide for regulating the conditions under which noise and vibration may be caused by aircraft on aerodromes and may provide that subsection (2) of this section shall apply to any aerodrome as respects which provision as to noise and vibration caused by aircraft is so made.

(2) No action shall lie in respect of nuisance by reason only of the noise and vibration caused by aircraft on an aerodrome to which this subsection applies by virtue of regulations under section 3 of this Act as long as the provisions of any such regulations are duly complied with.

#### **Part V – Miscellaneous**

**14.** (1) Where default is made in the payment of airport charges or air navigation charges incurred in respect of any aircraft at an aerodrome to which this section applies, the aerodrome authority may, subject to the provisions of this section —

- (a) detain, pending payment, either —
  - (i) the aircraft in respect of which the charges were incurred (whether or not they were incurred by the person who is the operator of the aircraft at the time when the detention begins); or
  - (ii) any other aircraft of which the person in default is the operator at the time when the detention begins; and
- (b) if the charges are not paid within 56 days of the date when the detention begins, sell the aircraft in order to satisfy the charges.

(2) An aerodrome authority shall not detain or continue to detain an aircraft under this section by reason of any alleged default in the payment of airport charges or air navigation charges to the operator of the aircraft or any other person claiming an interest therein —

- (a) disputes that the charges, or any of them, are due or, if the aircraft is detained under subsection (1)(a)(i) above, that the charges in question were incurred in respect of that aircraft; and
- (b) gives to the aerodrome authority, pending the determination of the dispute, sufficient security for the payment of the charges which are alleged to be due.

(3) An aerodrome authority shall not sell an aircraft under this section without the leave of the court and the court shall not give leave except on proof—

- (a) that a sum is due to the aerodrome authority for airport charges or air navigation charges;
- (b) that default has been made in the payment thereof; and
- (c) that the aircraft which the aerodrome authority seeks leave to sell is liable to sale under this section by reason of the default.

(4) An aerodrome authority proposing to apply for leave to sell an aircraft under this section shall take such steps as may be prescribed —

- (a) for bringing the proposed application to the notice of persons whose interests may be affected by the determination of the court thereon; and
- (b) for affording to any such person an opportunity of becoming a party to the proceedings on the application,

and, if leave is given, the aerodrome authority shall secure that the aircraft is sold for the best price that can reasonably be obtained.

(5) Failure to comply with any requirement of subsection (4) above in respect of any sale, while actionable as against the aerodrome authority concerned at the suit of any person suffering loss in consequence thereof, shall not, after the sale has taken place, be a ground for impugning its validity.

(6) The proceeds of any sale under this section shall be applied as follows, and in the following order, that is to say —

- (a) in payment of any tax chargeable on imported goods which is due in consequence of the aircraft's having been brought into Seychelles;
- (b) in payment of the expenses incurred by the aerodrome authority in detaining, keeping and selling the aircraft, including their expenses in connection with the application to the court;
- (c) in payment of the airport charges and air navigation charges which the court has found to be due, and the surplus, if any, shall be paid to or among the person or persons whose interests in the aircraft have been divested by reason of the sale.

(7) The power of detention and sale conferred by this section in respect of an aircraft extends to the equipment of the aircraft and any stores for use in connection with its operation (being equipment and stores carried in the aircraft) whether or not the property of the person who is its operator, and references to the aircraft in subsections (2) to (6) above include, except where the context otherwise requires, references to any such equipment and stores.

(8) The power of detention conferred by this section in respect of an aircraft extends to any aircraft documents carried in it, and any such documents may, if the aircraft is sold under this section, be transferred by the aerodrome authority to the purchaser.

(9) The power conferred by this section to detain an aircraft in respect of which charges have been incurred may be exercised on the occasion on which the charges have been incurred or on any subsequent occasion when the aircraft is on any aerodrome in Seychelles.

(10) This section applies to any Government aerodrome or any aerodrome licensed in pursuance of regulations under section 3 of this Act; and in this section —

“aerodrome authority” in relation to any aerodrome, means the person owning or managing it;

“airport charges” means charges payable to an aerodrome authority for the use of, or for services provided at, an aerodrome;

“air navigation charges” means any fees or charges payable by virtue of regulations made under this Act;

“aircraft documents”, in relation to any aircraft, means any certificate of registration, maintenance or airworthiness of that aircraft, any log book relating to the use of that aircraft or its equipment and any similar document.

(11) Nothing in this section shall prejudice any rights of an aerodrome authority to recover any charges, or any part thereof by action.

**15.** (1) Any services rendered in assisting, or in saving life from, or in saving the cargo or apparel of, an aircraft in, on or over the sea or any tidal water, or on or over the shores of the sea or any tidal water shall be deemed to be salvage services in all cases in which they would have been salvage services if they had been rendered in relation to a vessel; and where salvage services are rendered by an aircraft to any property or person, the owner of the aircraft shall be entitled to the same reward for those services as he would have been entitled to if the aircraft had been a vessel.

The foregoing provisions of this subsection shall have effect notwithstanding that the aircraft concerned is a foreign aircraft and notwithstanding that the services in question are rendered elsewhere than within the limits of the territorial waters adjacent to any part of the Republic.

(2) The Minister may by regulations direct that any provisions of any law of the Republic for the time being in force which relate to wreck, to salvage of life or property or to the duty of rendering assistance to vessels in distress shall, with such exceptions, adaptations and modifications, if any, as may be specified in the regulations, applied in relation to aircraft as those provisions apply in relation to vessels.



(3) the purposes of this section, any provisions of any law of the Republic which relate to vessels laid by or neglected as unfit for sea service shall be deemed to be provisions relating to wreck.

**16.** (1) Any lawful entry into the Republic or any lawful transit across the Republic, with or without landings, of an aircraft to which this section applies shall not entail any seizure or detention of the aircraft or any proceedings being brought against the owner or operator thereof or any other interference therewith by or on behalf of any person in the Republic on the ground that the construction, mechanism, parts, accessories or operation of the aircraft is or are an infringement of any patent, design or model.

(2) The importation into, and storage in, the Republic of spare parts and spare equipment for an aircraft to which this section applies and the use and installation thereof in the repair of such an aircraft shall not entail any seizure or detention of the aircraft or of the spare parts or spare equipment or any proceedings being brought against the owner or operator of the aircraft or the owner of the spare parts or spare equipment or any other interference with the aircraft by or on behalf of any person in the Republic on the ground that the spare parts or spare equipment or their installation are or is an infringement of any patent, design or model:

Provided that this subsection shall not apply in relation to any spare parts or spare equipment which are sold or distributed in the Republic or are exported from the Republic for sale or distribution.

(3) This section applies —

- (a) to an aircraft, other than an aircraft used in military, customs or police services, registered in any country or territory in the case of which there is for the time being in force a declaration made by the Minister, with a view to the fulfilment of the provisions of the Chicago Convention to which this section relates, that the benefits of those provisions apply to that country or territory, and
- (b) to such other aircraft as the Minister may by regulations specify.

## **Part VI – Supplemental**

**17.** (1) Any order or regulation made under this Act, or instructions given by the Minister thereunder, may contain such incidental and supplementary provisions as appear to the Minister to be necessary or expedient for the purposes of the order, regulation or instructions; and any such regulation may authorize the Minister to give instructions for the purposes of the regulation in respect of such matters as may be specified in the regulation.

(2) Any reference in this Act to the provisions of regulations shall include a reference to the provisions of any order or regulation made or instruction given under the regulations.

**18.** Any order or regulation made under this Act in relation to aircraft may provide for the detention of aircraft to secure compliance with the order or regulation, as the case may be, or with any provision of this Act and may make such further provision as appears to the Minister to be necessary or expedient for securing such detention.

**19.** Notwithstanding that any regulation or order made under this Act by the Minister has effect only as part of the law of the Republic, no provision contained in the order or regulation shall, on the ground that it would have extra-territorial operation, be deemed to be invalid in so far as it applies to aircraft registered in the Republic wherever they may be, or prohibits, requires or regulates —

- (a) the doing of anything by persons in, or any of the personnel of, such aircraft as aforesaid, wherever they may be, or
- (b) the doing of anything in relation to such aircraft as aforesaid by other persons being citizens of the Republic, wherever they may be.

For the purposes of this section, the personnel of an aircraft shall be deemed to include the commander or other person in charge of the aircraft and all other members of the crew of the aircraft.

**20.** Any offence under this Act or under an order or regulation made thereunder shall, for the purpose of conferring jurisdiction, be deemed to have been committed in any place where the offender may for the time being be.

**21.** (1) Any act or omission taking place on board an aircraft under the control of the Republic which is in flight elsewhere than in or over the Republic, which if taking place in the Republic would constitute an offence under the law in force in the Republic shall constitute that offence but this section shall not apply to any act or omission which is expressly or impliedly authorised by or under that law when taking place outside the Republic.

(2) No proceeding for any offence under the law in force in the Republic committed on board an aircraft which is in flight elsewhere than in or over the Republic (other than an offence under this Act or any order or regulation made thereunder) shall be instituted except by or with the consent of the Attorney General.

(3) For the purpose of conferring jurisdiction, any offence under the law in force in the Republic committed on board an aircraft in flight shall be deemed to have been committed in any place in the Republic where the offender may for the time being be.

(4) For the purpose of this section, the period during which an aircraft is in flight shall be deemed to include any period from the moment when power is applied for the purpose of the aircraft taking off on a flight until the moment when landing run (if any) at the termination of that flight ends; and any reference in this section to an aircraft in flight shall include a reference to an aircraft during any period when it is on the surface of the sea or land but not within the territorial limits of any country.

(5) In this section —

“an aircraft under the control of the Republic” means an aircraft —

- (a) which is for the time being registered in the Republic;
- (b) which is not for the time being registered in any country but in the case of which either the operator of the aircraft or each person entitled as owner to any legal or beneficial interest in it satisfies the following requirements, namely —
  - (i) that he is a person qualified to be the owner of a legal or beneficial interest in an aircraft registered in the Republic; and
  - (ii) that he resides or has his principal place of business in the Republic; or
- (c) which being for the time being registered in another country is for the time being chartered by demise to a person who or to persons each of whom satisfies the requirements aforesaid.

**22.** (1) Subject to subsection (2), nothing in this Act shall apply to any aircraft belonging to, or exclusively employed in the service of, the Republic.

(2) The Minister may, by regulation, apply to any such aircraft as is referred to in subsection (1), with or without modification, any of the provisions of this Act or any orders or regulations made thereunder.

(3) Nothing in this Act or in any instrument made thereunder shall prejudice or affect the rights, powers or privileges of any general or local lighthouse authority.

#### **Part VII - General**

**23.** Where a person who is not a resident of Seychelles or a body corporate that is incorporated outside Seychelles is convicted of an offence under this Act or an order or regulation made thereunder and a fine is imposed, the Court may order the person or body corporate to pay the equivalent sum in any foreign currency specified by the Court.

**24.** The provisions of the Air Navigation (Overseas Territories) Order —

- (a) shall have effect as if they were provisions of regulations made under this Act; and
- (b) may be amended by the Minister in exercise of the powers conferred by this Act.

**25.** The Civil Aviation Act 1949 (Overseas Territories) Order, 1969 is repealed.

---

**LAWS OF SEYCHELLES**  
**CIVIL AVIATION ACT**  
**SUBSIDIARY LEGISLATION**

**Paragraph 1 of the Schedule**

**The Air Navigation (Overseas Territories) Order**

S.I. 35 of 1976.  
S.I. 72 of 1976.

*Made .. .. . 17th March 1976*

*Laid before Parliament . . . . 5th April 1976*

*Coming into Operation -*

*(a) for the purposes of Articles 87 and 89 26th April 1976*

*(b) for all other purposes .. .. . 1st November 1976*

ARRANGEMENT OF ORDER

CITATION, COMMENCEMENT AND REVOCATION

1. Citation and commencement.
2. Revocation.

PART I

REGISTRATION AND MARKING OF AIRCRAFT

3. Aircraft to be registered.
4. Registration of aircraft in Seychelles.
5. Nationality and registration marks.

PART II

AIR OPERATORS' CERTIFICATES

6. Issue of air operators' certificates.

### PART III

#### AIRWORTHINESS AND EQUIPMENT OF AIRCRAFT

7. Certificate of airworthiness to be in force.
8. Issue, renewal, etc., of certificates of airworthiness.
9. Certification of maintenance.
10. Maintenance of General Purpose Category aircraft.
11. Inspection, overhaul, repair, replacement and modification.
12. Licensing of maintenance engineers.
13. Equipment of aircraft.
14. Radio equipment of aircraft.
15. Aircraft, engine and propeller log books.
16. Aircraft weight schedule.
17. Access and inspection for airworthiness purposes.

### PART VI

#### AIRCRAFT CREW AND LICENSING

18. Composition of crew of aircraft.
19. Members of flight crew - requirement of licences.
20. Grant, Renewal and Effect of Flight Crew Licences.
21. Validation of licences.
22. Personal flying log book.
23. Instruction in flying.
24. Glider pilot - minimum age.

### PART V

#### OPERATION OF AIRCRAFT

25. Operations Manual.

26. Training manual.
27. Public transport - operator's responsibilities.
28. Loading - public transport aircraft and suspended loads.
29. Public transport - operating conditions.
30. Aircraft registered in Seychelles - aerodrome operating minima.
31. Aircraft not registered in Seychelles - aerodrome operating minima.
32. Pre-flight action by commander of aircraft.
33. Pilots to remain at controls.
34. Public transport of passengers - duties of commander.
35. Operation of radio in aircraft.
36. Use of flight data recorders and preservation of records.
37. Towing of gliders.
38. Towing, picking up and raising of persons and articles.
39. Dropping of persons and articles.
40. Carriage of weapons and of munitions of war.
41. Carriage of dangerous goods.
42. Method of carriage of persons.
43. Exits and break-in markings.
44. Imperilling safety of aircraft.
45. Imperilling safety of any person or property.
46. Drunkenness in aircraft.
47. Smoking in aircraft.
48. Authority of commander of aircraft.
49. Stowaways.

## PART VI

## FATIGUE OF CREW

50. Application and interpretation of Part VI.
51. Fatigue of crew - operators responsibilities.
52. Fatigue of crew - responsibilities of crew.
53. Flight times - responsibilities of flight crews.

## PART VII

### DOCUMENTS AND RECORDS

54. Documents to be carried.
55. Records to be kept.
56. Production of documents and records.
57. Preservation of documents, etc.
58. Revocation, suspension and variation of certificates, licences and other documents.
59. Offences in relation to documents and records.

## PART VII

### CONTROL OF AIR TRAFFIC

60. Rules of the air and air traffic control.
61. Licensing of air traffic controllers and student air traffic controllers.
62. Prohibition of unlicensed air traffic controllers.
63. Incapacity of air traffic controllers.
64. Power to prohibit or restrict flying.
65. Balloons, kites and airships.

## PART IX

### AERODROMES, AERONAUTICAL LIGHTS AND DANGEROUS LIGHTS

66. Aerodromes: public transport of passengers and instruction in flying.



67. Use of Government aerodromes.
68. Licensing of aerodromes.
69. Radio Equipment at aerodromes.
70. Records at aerodromes.
71. Charges at aerodromes licensed for public use.
72. Use of aerodromes by aircraft of Contracting States and of the Commonwealth.
73. Noise and vibration caused by aircraft on aerodromes.
74. Aeronautical lights.
75. Dangerous lights.
76. Customs airports.

#### PART X

#### GENERAL

77. Prohibited Areas.
78. Restriction with respect to aerial photography and survey from aircraft registered outside Seychelles.
79. Mandatory Reporting.
80. Power to prevent aircraft flying.
81. Right of access to aerodromes and other places.
82. Obstruction of persons.
83. Enforcement of directions.
84. Penalties.
85. Extra-territorial effect of the Order.
86. Application of Order to British-controlled aircraft not registered in Seychelles.
87. Exemption from Order.
88. Appeal to Supreme Court.

- 89. Regulations by the Minister: Fees
- 90. Interpretation.
- 91. Saving.
- 92. Small aircraft.

## SCHEDULES

- Schedule 1 - Part A. Table of General Classification of Aircraft.  
Part B. Nationality and Registration Marks of Aircraft Registered in Seychelles.  
Part C. Aircraft Dealers Certificate - Conditions.
- Schedule 2 - A and B conditions.
- Schedule 3 - Categories of Aircraft.
- Schedule 4 - Maintenance Engineers: Privileges of Licences.
- Schedule 5 - Aircraft Equipment.
- Schedule 6 - Radio equipment to be carried in aircraft.
- Schedule 7 - Aircraft, Engine and Propeller Log Books.
- Schedule 8 - Areas Specified in connection with the Carriage of Flight Navigators as Members of the Flight Crews of Public Transport Aircraft.
- Schedule 9 - Flight Crew of Aircraft: Licences and Ratings.
- Schedule 10 - Air Traffic Controllers: Ratings.
- Schedule 11 - Public Transport: Operational Requirements.
- Schedule 12 - Documents to be Carried by Aircraft Registered in Seychelles.
- Schedule 13 - Penalties.
- Schedule 14 - Rules of the Air and Air Traffic Control.
- Schedule 15 - Air Navigation (General) Regulations.

## CITATION, COMMENCEMENT AND REVOCATION

*Citation and commencement*

1. (1) This Order may be cited as the Air Navigation (Overseas Territories) Order.

(2) This Order shall come into operation -

(a) on 26th April, 1976, for the purposes of Articles 87 and 89;

(b) on 1st November 1976, for all other purposes.

*Revocation*

2. (1) Subject to the following provisions of this Article, the following Orders are hereby revoked, in so far as they apply as part of the law of Seychelles -

The Colonial Air Navigation Order 1961(a);

The Colonial Air Navigation (Amendment) Order 1962(b);

The Colonial Air Navigation (Amendment) Order 1963(c);

The Colonial Air Navigation (Amendment) Order 1965(d);

The Colonial Air Navigation (Amendment) Order 1968(e);

The Colonial Air Navigation (Amendment) Order 1972(f):

---

(a) S.I. 1961/2316 (1961 III, p.4146).

(b) S.I. 1962/2597 (1962 III, p. 3485).

(c) S.I. 1963/1966 (1963 III, p. 3831).

(d) S.I. 1965/588 (1965 I, p. 1845).

(e) S.I. 1968/1090 (1968 II, p. 2943).

(f) S.I. 1972/445 (1972 I, p. 1649).

Provided that the Thirteenth Schedule to the Colonial Air Navigation Order 1961 (which specifies fees) as substituted by Article 11 of the Colonial Air Navigation (Amendment) Order 1968 shall remain in force until revoked and replaced by fees prescribed under Article 89 of this Order, and in the meantime may be varied by the Minister as if prescribed by him under that Article.

(2) Section 38(2) of the Interpretation Act 1989(g) of the United Kingdom (which relates to the effect of repeals) shall apply to this Order as if this Order were an Act of Parliament and as if the Orders revoked by paragraph (1) of this Article were Acts of Parliament thereby repealed.

(3) Notwithstanding the revocation of the Orders mentioned in paragraph (1) of this Article, any instrument (that is to say any regulation, direction, instrument, rule or other requirement, any notice and any certificate, licence, approval, permission, exemption, log book, record or other document) issued, made, served or granted under those Orders, or under any enactment revoked by any of those Orders, if in force at the commencement of this Order, shall (except to the extent that such instrument is inconsistent with the provisions of this Order, and without prejudice to Article 58 of this Order or to any power to amend any such instrument) continue in force until superseded, revoked or otherwise terminated and, so far as it could have been issued, made, served or granted under this Order and this Order shall apply to or in relation to such instrument accordingly:

Provided that any such instrument which is expressed to remain in force for a definite period shall not remain in force after the expiration of that period unless it shall be renewed in accordance with the provisions of this Order or in accordance with any prescribed provisions.

---

(g) 1889 c. 63.

## PART I

### REGISTRATION AND MARKING OF AIRCRAFT

#### *Aircraft to be Registered*

3. (1) An aircraft shall not fly in or over Seychelles unless it is registered in:
- (a) Seychelles or some part of the Commonwealth; or
  - (b) a Contracting State; or
  - (c) some other country in relation to which there is in force an agreement between the Government of Seychelles and the Government of that country which makes provision for the flight over Seychelles of aircraft registered in that country:

Provided that:

- (i) a glider may fly unregistered, and shall be deemed to be registered in Seychelles for the purposes of Articles 13, 14, 19 and 32 of this Order, on any flight which:
  - (a) begins and ends in Seychelles without passing over any other country, and
  - (b) is not for the purpose of public transport or aerial work;
- (ii) any aircraft may fly unregistered on any flight which:
  - (a) begins and ends in Seychelles without passing over any other country, and
  - (b) is in accordance with the "B Conditions" set forth in Schedule 2 to this Order;
- (iii) this paragraph shall not apply to any kite or captive balloon.

(2) If an aircraft flies over Seychelles in contravention of paragraph (1) of this Article in such manner or circumstances that if the aircraft had been registered in Seychelles an offence against this Order or any regulations made thereunder would have been committed, the like offence shall be deemed to have been committed in respect of that aircraft.

#### *Registration of aircraft in Seychelles*

4. (1) The Minister shall be the authority for the registration of aircraft in Seychelles and shall cause a register to be kept.

(2) Subject to the provisions of this Article, an aircraft shall not be registered or continue to be registered in Seychelles if it appears to the Minister that:

- (a) the aircraft is registered outside Seychelles and that such registration does not cease by operation of law upon the aircraft being registered in Seychelles; or
- (b) an unqualified person holds any legal or beneficial interest by way of ownership in the aircraft or any share therein; or
- (c) the aircraft could more suitably be registered in some other part of the Commonwealth; or
- (d) it would be inexpedient in the public interest for the aircraft to be or to continue to be registered in Seychelles.

(3) The following persons and no others shall be qualified to hold a legal or beneficial interest by way of ownership in an aircraft registered in Seychelles or a share therein:

- (a) the Government of Seychelles;
- (b) citizens of Seychelles or British subjects;
- (c) citizens of the Republic of Ireland;
- (d) British protected persons;
- (e) bodies incorporated in Seychelles or some part of the Commonwealth and having their principal place of business in Seychelles or in any part of the Commonwealth;
- (f) firms carrying on business in Scotland.

In this sub-paragraph "firm" has the same meaning as in the Partnership Act 1890(a).

(4) If an unqualified person residing or having a place of business in Seychelles holds a legal or beneficial interest by way of ownership in an aircraft, or a share therein, the Minister, upon being satisfied that the aircraft may otherwise be properly so registered, may register the aircraft in Seychelles. The person aforesaid shall not cause or permit the aircraft, while it is registered in pursuance of this paragraph, to be used for the purpose of public transport or aerial work.

(5) If an aircraft is chartered by demise to a person qualified as aforesaid the Minister may, whether or not an unqualified person is entitled as owner to a legal or beneficial interest therein, register the aircraft in Seychelles in the name of the charterer upon being satisfied that the aircraft may otherwise be properly so registered, and

subject to the provisions of this Article the aircraft may remain so registered during the continuation of the charter.

(6) Application for the registration of an aircraft in Seychelles shall be made in writing to the Minister, and shall include or be accompanied by such particulars and evidence relating to the aircraft and the ownership and chartering thereof as he may require to enable him to determine whether the aircraft may properly be registered in Seychelles and to issue the certificate referred to in paragraph (8) of this Article. In particular, the application shall include the proper description of the aircraft according to column 4 of the "General Classification of Aircraft" set forth in Part A of Schedule 1 to this Order.

(7) Upon receiving an application for the registration of an aircraft in Seychelles and being satisfied that the aircraft may properly be so registered, the Minister shall register the aircraft, wherever it maybe, and shall include in the register the following particulars:

- (a) the number of the certificate;
- (b) the nationality mark of the aircraft, and the registration mark assigned to it by the Minister,
- (c) the name of the constructor of the aircraft and its designation;
- (d) the serial number of the aircraft;
- (e)
  - (i) the name and address of every person who is entitled as owner to a legal interest in the aircraft or a share therein, or in the case of an aircraft which is the subject of a charter by demise, the name and address of the charterer by demise; and
  - (ii) in the case of an aircraft registered in pursuance of paragraph (4) or (5) of this Article, an indication that it is so registered.

(8) The Minister shall furnish to the person in whose name the aircraft is registered (hereinafter in this Article referred to as "the registered owner") a certificate of registration, which shall include the foregoing particulars and the date on which the certificate was issued:

Provided that the Minister shall not be required to furnish a certificate of registration if the registered owner is the holder of an aircraft dealer's certificate granted under this Order who has made to the Minister and has not withdrawn a statement of his intention that the aircraft is to fly only in accordance with the conditions set forth in Part C of Schedule 1 to this Order, and in that case the aircraft shall fly only in accordance with those conditions.

---

(a) 1890 c. 39.

(9) The Minister may grant to any person qualified as aforesaid an aircraft dealer's certificate if he is satisfied that he has a place of business in Seychelles for buying and selling aircraft.

(10) Subject to paragraphs (4) and (5) of this Article, if at any time after an aircraft has been registered in Seychelles an unqualified person becomes entitled to a legal or beneficial interest by way of ownership in the aircraft or a share therein, the registration of the aircraft shall thereupon become void and the certificate of registration shall forthwith be returned by the registered owner to the Minister.

(11) Any person who is the registered owner of an aircraft registered in Seychelles shall forthwith inform the Minister in writing of:

- (a) any change in the particulars which were furnished to the Minister upon application being made for the registration of the aircraft;
- (b) the destruction of the aircraft, or its permanent withdrawal from use;
- (c) in the case of an aircraft registered in pursuance of paragraph (5) of this Article, the termination of the demise charter.

(12) Any person who becomes the owner of an aircraft registered in Seychelles shall forthwith inform the Minister in writing to that effect.

(13) The Minister may, whenever it appears to him necessary or appropriate to do so for giving effect to this Part of this Order or for bringing up to date or otherwise correcting the particulars entered on the register, amend the register or, if he thinks fit, may cancel the registration of the aircraft, and shall cancel that registration if he is satisfied that there has been a change in the ownership of the aircraft.

(14) The Minister may, by regulations, adapt or modify the foregoing provisions of this Article as he deems necessary or expedient for the purpose of providing for the temporary transfer of aircraft to or from Seychelles register, either generally or in relation to a particular case or class of cases.

(15) In this Article references to an interest in an aircraft do not include references to an interest in an aircraft to which a person is entitled only by virtue of his membership of a flying club and the reference in paragraph (11) of this Article to the registered owner of an aircraft includes in the case of a deceased person, his legal personal representative, and in the case of a body corporate which has been dissolved, its successor.

(16) Nothing in this Article shall require the Minister to cancel the registration of an aircraft if in his opinion it would be inexpedient in the public interest to do so.



(17) The Minister shall transmit to the Civil Aviation Authority particulars of all registrations and of changes in or cancellation of registrations, entered in the register.

*Nationality and registration marks*

5. (1) An aircraft (other than an aircraft permitted by or under this Order to fly without being registered) shall not fly unless it bears painted thereon or affixed thereto, in the manner required by the law of the country in which it is registered, the nationality and registration marks required by that law.

(2) The marks to be borne by aircraft registered in Seychelles shall comply with Part B of Schedule 1 to this Order.

(3) An aircraft shall not bear any marks which purport to indicate:

- (a) that the aircraft is registered in a country in which it is not in fact registered; or
- (b) that the aircraft is a State aircraft of a particular country if it is not in fact such an aircraft, unless the appropriate authority of that country has sanctioned the bearing of such marks.

PART II

AIR OPERATORS' CERTIFICATES

*Issue of Air operators' certificates*

6. (1) An aircraft registered in Seychelles and having a maximum total weight authorised of more than 2,300 kg., shall not fly on any flight for the purpose of public transport, otherwise than under and in accordance with the terms of an air operator's certificate granted to the operator of the aircraft under paragraph (2) of this Article, certifying that the holder of the certificate is competent to secure that aircraft operated by him on such flights as that in question are operated safely.

(2) The Minister may grant to any person applying therefor an air operator's certificate if he is satisfied that that person is competent, having regard in particular to his previous conduct and experience, his equipment, organisation, staffing, maintenance and other arrangements, to secure the safe operation of aircraft of the types specified in the certificate on flights of the description and for the purposes so specified. The certificate may be granted subject to such conditions as the Minister thinks fit and shall, subject to the provisions of Article 58 of this Order, remain in force for the period specified in the certificate.

PART III

AIRWORTHINESS AND EQUIPMENT OF AIRCRAFT

*Certificate of airworthiness to be in force*

**7.** (1) An aircraft shall not fly unless there is in force in respect thereof a certificate of airworthiness duly issued or rendered valid under the law of the country in which the aircraft is registered, and any conditions subject to which the certificate was issued or rendered valid are complied with:

Provided that the foregoing prohibition shall not apply to flights, beginning and ending in Seychelles without passing over any other country, of:

- (a) a glider, if it is not being used for the public transport of passengers or aerial work;
- (b) a balloon, if it is not being used for the public transport of passengers;
- (c) a kite;
- (d) an aircraft flying in accordance with the "A Conditions" or the "B Conditions" set forth in Schedule 2 to this Order;
- (e) an aircraft flying in accordance with the conditions of a permit to fly issued by the Minister in respect of that aircraft.

(2) In the case of an aircraft registered in Seychelles the certificate of airworthiness referred to in paragraph (1) of this Article shall be a certificate issued or rendered valid in accordance with the provisions of Article 8 of this Order.

*Issue, renewal, etc., of certificates of airworthiness*

**8.** (1) The Minister may issue in respect of any aircraft a certificate of airworthiness if he is satisfied that the aircraft is fit to fly having regard to:

- (a) the design, construction, workmanship and materials of the aircraft (including in particular any engines fitted therein), and of any equipment carried in the aircraft which he considers necessary for the airworthiness of the aircraft; and
- (b) the results of flying trials, and such other tests of the aircraft as he may require:

Provided that, if the Minister has issued a certificate of airworthiness in respect of an aircraft which, in his opinion, is a prototype aircraft or a modification of a prototype aircraft, he may dispense with flying trials in the case of any other aircraft if he is satisfied that it conforms to such prototype or modification.

(2) Every certificate of airworthiness shall specify such categories as are, in the opinion of the Minister, appropriate to the aircraft in accordance with Schedule 3 to this Order and the certificate shall be issued subject to the condition that the aircraft

shall be flown only for the purposes indicated in the said Schedule in relation to those categories:

Provided that:

- (i) the General Purpose Category shall be specified only in respect of an aircraft of which the maximum total weight authorised does not exceed 2,730 kg;
  - (ii) only the General Purpose Category or the Special Category shall be specified in respect of such an aircraft.
- (3) The Minister may issue the certificate of airworthiness subject to such other conditions relating to the airworthiness of the aircraft as he thinks fit.
- (4) The certificate of airworthiness may designate the performance group to which the aircraft belongs for the purposes of the requirements referred to in Article 29(1) of this Order.
- (5) The Minister may, subject to such conditions as he thinks fit, issue a certificate of validation rendering valid for the purposes of this Order a certificate of airworthiness issued in respect of any aircraft under the law of any country other than Seychelles.
- (6) Subject to the provisions of this Article and of Article 58 of this Order, a certificate of airworthiness or validation issued under this Article shall remain in force for such period as may be specified therein, and may be renewed from time to time by the Minister for such further period as he thinks fit.
- (7) A certificate of airworthiness or a certificate of validation issued in respect of an aircraft shall cease to be in force:
- (a) if the aircraft, or such of its equipment as is necessary for the airworthiness of the aircraft is overhauled, repaired or modified, or if any part of the aircraft or of such equipment is removed or is replaced, otherwise than in a manner and with material of a type approved by the Minister either generally or in relation to a class of aircraft or to the particular aircraft; or
  - (b) until the completion of any inspection of the aircraft or of any such equipment as aforesaid, being an inspection required by the Minister to be made for the purpose of ascertaining whether the aircraft remains airworthy; or
  - (c) until the completion to the satisfaction of the Minister of any modification of the aircraft or of any such equipment as aforesaid, being a modification required by the Minister for the purpose of ensuring that the aircraft remains airworthy.

(8) Without prejudice to any other provision of this Order the Minister may, for the purposes of this Article, accept reports furnished to him by a person whom he may approve, either absolutely or subject to such conditions as he thinks fit, as qualified to furnish such reports.

*Certificate of maintenance*

9. (1) An aircraft registered in Seychelles (not being an aircraft in respect of which a certificate of airworthiness of the General Purpose Category or the Special Category is in force) shall not fly for the purpose of public transport or dropping or projecting any material for agricultural, public health or similar purposes unless:

- (a) the aircraft (including in particular its engines), together with its equipment and radio station, is maintained in accordance with maintenance schedules approved by the Minister in relation to that aircraft;
- (b) there are in force in respect of that aircraft certificates (in this Order referred to as "certificates of maintenance") issued in accordance with the provisions of this Article and certifying that maintenance has been carried out in accordance with such maintenance schedules:

Provided that an aircraft may, notwithstanding that sub-paragraphs (a) and (b) have not been complied with in relation to the radio station therein, fly for the sole purpose of enabling persons to be trained to perform duties in aircraft.

(2) An aeroplane registered in Seychelles (not being an aeroplane in respect of which a certificate of airworthiness of the General Purpose Category or the Special Category is in force) shall not fly unless the flight data recording system, if any, required by or under this Order to be carried, is maintained in accordance with a maintenance schedule approved by the Minister in relation to that equipment and there is in force in respect of that equipment a certificate of maintenance issued in accordance with the provisions of this Article and certifying that maintenance has been carried out in accordance with such maintenance schedule.

(3) Every certificate of maintenance shall come into force upon being issued and shall cease to be in force upon the expiration of the period of its validity in elapsed time or flying time, whichever may be the earlier, as specified in the relevant maintenance schedule, and the period of validity of the certificate shall be recorded in the certificate at the time when it is issued.

(4) A certificate of maintenance may be issued for the purposes of this Article only by -

- (a) the holder of a licence granted under this Order as an aircraft maintenance engineer being a licence of a category appropriate in accordance with Article 12 of and Schedule 4 to this Order; or

- (b) the holder of a licence as such an engineer granted under the law of a country other than Seychelles and rendered valid under this Order, in accordance with the privileges endorsed on the licence; or
- (c) the holder of a licence as such an engineer granted under the law of any country specified in Regulation 10 in Schedule 15 to this Order, in accordance with the privileges endorsed on the licence and subject to any conditions specified in that Schedule; or
- (d) a person whom the Minister has authorised to issue a certificate of maintenance in a particular case, and in accordance with that authority:

Provided that, upon approving a maintenance schedule, the Minister may direct that certificates of maintenance relating to that schedule, or to any part thereof specified in its direction, may be issued only by the holder of such a licence as is so specified.

(5) Certificates of maintenance shall be issued in duplicate. One of the duplicates shall, during the period of validity of the certificate, be carried in the aircraft when Article 54 of this Order so requires, and the other shall be kept by the operator elsewhere than in the aircraft.

(6) On the termination of every flight by an aircraft registered in Seychelles for any of the purposes specified in paragraph (1) of this Article, the commander of the aircraft shall enter in a technical log:

- (a) the times when the aircraft took off and landed; and
- (b) particulars of any defect in any part of the aircraft or its equipment which is known to him, being a part to which a maintenance schedule relates, or, if no such defect is known to him, an entry to that effect,

and shall sign and date such entries:

Provided that in the case of a number of consecutive flights beginning and ending on the same day and with the same person as commander of the aircraft, the commander of an aircraft -

- (i) flying for the purpose of public transport where each of the aforesaid consecutive flights begins at the same aerodrome and ends at that aerodrome, or
- (ii) flying for the purpose of dropping or projecting any material for agricultural, public health or similar purposes,

may, except where he becomes aware of a defect during an earlier flight, make the entries as aforesaid in a technical log at the end of the last of such consecutive flights.

(7) Upon the rectification of any defect which has been entered in a technical log in accordance with paragraph (6) of this Article, a copy of the certificate of compliance required by Article 11 of this Order in respect of the work done for the rectification of the defect shall be entered in the technical log in such a position or manner as to be readily identifiable with the entry of the defect to which it relates.

(8) The technical log referred to in paragraphs (6) and (7) of this Article shall be carried in the aircraft when Article 54 of this Order so requires and copies of the entries referred to in those paragraphs shall be kept on the ground.

(9) Subject to the provisions of Article 57 of this Order every certificate of maintenance shall be preserved by the operator of the aircraft for a period of two years following the expiration of the period of validity of the certificate and for such further period as the Minister may require in any particular case.

*Maintenance of General Purpose Category aircraft*

**10.** (1) An aircraft registered in Seychelles being an aircraft in respect of which a certificate of airworthiness of the General Purpose Category is in force shall not fly unless the aircraft (including in particular its engines), together with its equipment and radio station, is maintained in accordance with a maintenance schedule approved by the Minister in relation to that aircraft and, if the aircraft is flying for the purpose of the public transport of passengers, unless there is in force a certificate (in this Order referred to as a "certificate of release") issued in accordance with the provisions of this Article and certifying that maintenance has been carried out in accordance with such a maintenance schedule:

Provided that an aircraft may, notwithstanding that the radio station has not been so maintained, fly for the sole purpose of enabling persons to be trained to perform duties in aircraft.

(2) Every certificate of release shall come into force upon being issued and shall cease to be in force upon the expiration of the period of its validity as specified in the relevant maintenance schedule, and the period of validity of the certificate shall be recorded in the certificate at the time when it is issued.

(3) A certificate of release may be issued for the purposes of this Article only by -

- (a) the holder of a licence granted under this Order as an aircraft maintenance engineer being a licence of a category appropriate in accordance with Article 12 of and Schedule 4 to this Order; or
- (b) the holder of a licence as such an engineer granted under the law of a country other than Seychelles and rendered valid under this Order, in accordance with the privileges endorsed on the licence; or

- (c) the holder of a licence as such an engineer granted under the law of any country specified in Regulation 10 in Schedule 15 to this Order, in accordance with the privileges endorsed on the licence and subject to any conditions specified in that Schedule; or
- (d) a person who the Minister has authorised to issue a certificate of release in a particular case, and in accordance with that authority.

(4) Certificates of release shall be issued in duplicate. One of the duplicates shall, during the period of validity of the certificate, be carried in the aircraft when Article 54 of this Order so requires, and the other shall be kept by the operator elsewhere than in the aircraft.

(5) On the termination of every flight by any such aircraft as aforesaid the commander of the aircraft shall enter in a log book -

- (a) the times when the aircraft took off and landed; and
- (b) particulars of any defect in any part of the aircraft or its equipment which is known to him, being a part to which a maintenance schedule relates, or, if no such defect is known to him, an entry to that effect,

and he shall sign and date every such entry -

Provided that in the case of a number of consecutive flights beginning and ending on the same day and with the same person as commander of the aircraft, that person may, except where he becomes aware of a defect during an earlier flight, make the entry as aforesaid in a log book at the end of the last of such consecutive flights.

*Inspection, overhaul, repair, replacement and modification*

**11** (1) An aircraft registered in Seychelles, being an aircraft in respect of which a certificate of airworthiness issued or rendered valid under this Order is in force, shall not fly (except as provided for in paragraph (2) of this Article) if any part of the aircraft or of such of its equipment as is necessary for the airworthiness of the aircraft, has been overhauled, repaired, replaced or modified, or has been inspected as provided in Article 8(7)(b) of this Order, unless there is in force a certificate of compliance issued in accordance with this Article and relating to the overhaul, repair, replacement, modification or inspection, as the case may be:

Provided that:

- (a) unless the Minister gives a direction to the contrary in the particular case nothing in this paragraph shall require a certificate of compliance to be in force in respect of an aircraft of which the maximum total weight authorised does not exceed 2,730 kg. and in respect of which a certificate of airworthiness of the Special Category is in force;

- (b) if a repair or replacement of a part of an aircraft or its equipment is carried out when the aircraft is at such place that it is not reasonably practicable -
  - (i) for the repair or replacement to be carried out in such a manner that a certificate of compliance can be issued under this Article in respect thereof, or
  - (ii) for such a certificate to be issued while the aircraft is at that place, the aircraft may fly to a place at which such a certificate can be issued, being the nearest place:
    - (aa) to which the aircraft can, in the reasonable opinion of the commander thereof, safely fly by a route for which it is properly equipped, and
    - (bb) to which it is reasonable to fly having regard to any hazards to the liberty or health of any person on board,

and in such case the commander of the aircraft shall cause written particulars of the flight, and the reasons for making it, to be given to the Minister within 10 days thereafter.

(2) Nothing in paragraph (1) of this Article shall prevent an aircraft of which the maximum total weight authorised does not exceed 2,730 kg. from flying otherwise than for the purpose of public transport if the only repairs or replacements in respect of which a certificate of compliance is not in force are of such a description as are specified in Regulation 13 in Schedule 15 to this Order and have been carried out personally by the owner or operator of the aircraft being the holder of a pilot's licence (other than a student pilot's licence) granted or rendered valid under this Order. In that event the owner or operator, as the case may be, of the aircraft, shall keep in a log book a record which identifies the repair or replacement and shall sign and date the entries, and, subject to the provisions of Article 57 of this Order, shall preserve the log book for a period of 2 years from the date of the last entry therein. Any equipment or parts used in carrying out such repairs or replacements shall be of a type approved by the Minister whether generally or in relation to a class of aircraft or the particular aircraft.

- (3) Neither:
  - (a) equipment provided in compliance with Schedule 5 of this Order (except paragraph (3) thereof), nor
  - (b) in the case of a public transport aircraft, radio apparatus provided for use therein or in any survival craft carried therein, whether or not such apparatus is provided in compliance with this Order or any regulation made thereunder,

shall be installed, or placed on board for use, in an aircraft registered in Seychelles after being overhauled, repaired or modified, unless there is in force in respect thereof at the



time when it is installed or placed on board a certificate of compliance issued in accordance with this Article and relating to the overhaul, repair or modification, as the case may be.

(4) For the purposes of this Order, "certificate of compliance" means a certificate that the part of the aircraft or its equipment has been overhauled, repaired, replaced or modified, as the case may be, in a manner and with material or a type approved by the Minister either generally or in relation to a class of aircraft or the particular aircraft and which identifies the overhaul, repair, replacement or modification to which it relates and includes particulars of the work done; and in relation to an inspection required by the Minister, that the inspection has been made in accordance with the requirement of the Minister and that any consequential repair or replacement has been carried out as aforesaid.

(5) A certificate of compliance may be issued for the purposes of this Article only by -

- (a) the holder of a licence granted under this Order as an aircraft maintenance engineer being a licence of a category appropriate in accordance with Article 12 of and Schedule 4 of this Order; or
- (b) the holder of a licence as such an engineer granted under the law of a country other than Seychelles and rendered valid under this Order, in accordance with the privileges endorsed on the licence; or
- (c) the holder of a licence as such an engineer granted under the law of any country specified in Regulation 10 in Schedule 15 to this Order, in accordance with the privileges endorsed on the licence and subject to any conditions specified in that Schedule; or
- (d) the holder of a licence or authorisation as such an engineer granted or issued by or under the law of any Contracting State in which the overhaul, repair, replacement, modification or inspection has been carried out, but only in respect of aircraft of which the maximum total weight authorised does not exceed 2,730 kg; or
- (e) a person approved by the Minister as being competent to issue such certificates; or
- (f) a person whom the Minister has authorised to issue the certificate in a particular case; or
- (g) in relation only to the adjustment and compensation of direct reading magnetic compasses, the holder of an Airline Transport Pilot's Licence (Aeroplanes), a Senior Commercial Pilot's Licence (Aeroplanes) or a Flight Navigator's Licence granted or rendered valid under this Order.

(6) Subject to the provisions of Article 57 of this Order, if the aircraft to which a certificate of compliance relates is a public transport aircraft or an aerial work aircraft, the certificate of compliance shall be preserved by the operator of the aircraft for the period of time for which he is required to preserve the log book relating to the same part of the aircraft or to the same equipment or apparatus as the case may be. In the case of any other aircraft the certificate shall be preserved by the operator of the aircraft for a period of 2 years.

(7) In this Article; the expression "repair" includes in relation to a compass the adjustment and compensation thereof and the expression "repaired" shall be construed accordingly.

#### *Licensing of maintenance engineers*

**12** (1) The Minister may grant to any person a licence to act for the purposes of this Order as an aircraft maintenance engineer of one of the categories specified in Schedule 4 to this Order, upon his being satisfied that the applicant is a fit person to hold the licence and is qualified by his knowledge, experience, competence and skill to do so, and for that purpose the applicant shall furnish such evidence and undergo such examinations and tests as the Minister may require of him. The Minister may include a rating in the licence limiting the licence to particular types of aircraft or equipment.

(2) A licence of any category shall, subject to any rating as aforesaid, entitle the holder to issue certificates of maintenance, certificates of release, certificates of compliance or certificates of fitness for flight in accordance with Schedule 4 of this Order.

(3) A licence and a rating shall, subject to the provisions of Article 58 of this Order, remain in force for the periods specified therein, not exceeding 2 years, but may be renewed by the Minister from time to time upon his being satisfied that the applicant is a fit person and is qualified as aforesaid.

(4) The Minister may issue a certificate rendering valid for the purposes of this Order any licence as an aircraft maintenance engineer or aircraft radio maintenance engineer granted under the law of any country other than Seychelles. Such certificate may be issued subject to such conditions, and for such period, as the Minister thinks fit.

(5) Upon receiving a licence granted under this Article, the holder shall forthwith sign his name thereon in ink with his ordinary signature.

#### *Equipment of aircraft*

**13** (1) An aircraft shall not fly unless it is so equipped as to comply with the law of the country in which it is registered, and to enable lights and markings to be displayed, and signals to be made, in accordance with this Order and any regulations made thereunder.

(2) In the case of aircraft registered in Seychelles the equipment required to be provided (in addition to any other equipment required by or under this Order) shall be that specified in such parts of Schedule 5 to this Order as are applicable in the circumstances and shall comply with the provisions of that Schedule. The equipment, except that specified in paragraph (3) of the said Schedule, shall be of a type approved by the Minister either generally or in relation to a class of aircraft or in relation to that aircraft and shall be installed in a manner so approved.

(3) In any particular case the Minister may direct that an aircraft registered in Seychelles shall carry such additional or special equipment or supplies as he may specify for the purpose of facilitating the navigation of the aircraft, the carrying out of search and rescue operations, or the survival of the persons carried in the aircraft.

(4) The equipment carried in compliance with this Article shall be so installed or stowed and kept stowed, and so maintained and adjusted, as to be readily accessible and capable of being used by the person for whose use it is intended.

(5) The position of equipment provided for emergency use shall be indicated by clear markings in or on the aircraft. In particular in every public transport aircraft registered in Seychelles there shall be-

- (a) exhibited in a prominent position in every passenger compartment;  
or
- (b) provided individually for each passenger,

a notice stating where the lifejackets (if any) are to be found, and containing instructions as to how they are to be used.

(6) All equipment installed or carried in an aircraft, whether or not in compliance with this Article, shall be so installed or stowed and kept stowed and so maintained and adjusted as not to be a source of danger in itself or to impair the airworthiness of the aircraft or the proper functioning of any equipment or services necessary for the safety of the aircraft.

(7) Without prejudice to paragraph (2) of this Article, all navigational equipment (other than radio apparatus) of any of the following types, namely:

- (a) equipment capable of establishing the aircraft's position in relation to its position at some earlier time by computing and applying the resultant of the acceleration and gravitational forces acting upon it, and
- (b) equipment capable of establishing automatically the altitude and relative bearing of selected celestial bodies,

when carried in an aircraft registered in Seychelles (whether or not in compliance with this Order or any regulations made thereunder) shall be of a type approved by the

Minister either generally or in relation to a class of aircraft or in relation to that aircraft and shall be installed in a manner so approved.

(8) This Article shall not apply in relation to radio apparatus except that specified in Schedule 5 to this Order.

*Radio equipment of aircraft*

**14** (1) An aircraft shall not fly unless it is so equipped with radio equipment as to comply with the law of the country in which the aircraft is registered and to enable communications to be made and the aircraft to be navigated, in accordance with the provisions of this Order and any regulations made thereunder.

(2) Without prejudice to paragraph (1) of this Article, the aircraft shall be equipped with radio equipment in accordance with Schedule 6 to this Order.

(3) In any particular case the Minister may direct that an aircraft registered in Seychelles shall carry such additional or special radio equipment as he may specify for the purpose of facilitating the navigation of the aircraft, the carrying out of search and rescue operations or the survival of the persons carried in the aircraft.

(4) Subject to such exceptions as may be prescribed the radio equipment provided in compliance with this Article in an aircraft registered in Seychelles shall always be maintained in serviceable condition.

(5) All radio equipment installed in an aircraft registered in Seychelles (whether or not in compliance with this Order or any regulations made thereunder) shall be of a type approved by the Minister in relation to the purpose for which it is to be used, and shall, except in the case of a glider which is permitted by Article 3(1) of this Order to fly unregistered, be installed in a manner approved by the Minister. Neither the equipment nor the manner in which it is installed shall be modified except with the approval of the Minister.

*Aircraft, engine and propeller log books*

**15** (1) In addition to any other log books required by or under this Order, the following log books shall be kept in respect of every public transport aircraft and aerial work aircraft registered in Seychelles:

- (a) an aircraft log book; and
- (b) a separate log book in respect of each engine fitted in the aircraft; and
- (c) a separate log book in respect of each variable pitch propeller fitted to the aircraft.

The log books shall include the particulars respectively specified in Schedule 7 to this Order.

(2) Each entry in the log book shall be made as soon as is practicable after the occurrence to which it relates, but in no event more than 7 days after the expiration of the certificate of maintenance (if any) in force in respect of the aircraft at the time of the occurrence.

(3) Entries in a log book may refer to other documents, which shall be clearly identified, and any other document so referred to shall be deemed, for the purposes of this Order, to be part of the log book.

(4) It shall be the duty of the operator of every aircraft in respect of which log books are required to be kept as aforesaid to keep them or cause them to be kept in accordance with the foregoing provisions of this Article.

(5) Subject to the provisions of Article 57 of this Order every log book shall be preserved by the operator of the aircraft until a date two years after the aircraft, the engine or the variable pitch propeller, as the case may be, has been destroyed or has been permanently withdrawn from use.

#### *Aircraft weight schedule*

**16** (1) Every flying machine and glider in respect of which a certificate of airworthiness issued or rendered valid under this Order is in force shall be weighed, and the position of its centre of gravity determined, at such times and in such manner as the Minister may require in the case of that aircraft.

(2) Upon the aircraft being weighed as aforesaid the operator of the aircraft shall prepare a weight schedule showing the basic weight of the aircraft, that is to say, the weight of the aircraft empty together with the weight of the unusable fuel and unusable oil in the aircraft and of such items of equipment as are indicated in the weight schedule; and showing the position of the centre of gravity of the aircraft when the aircraft contains only the items included in the basic weight.

(3) Subject to the provisions of Article 57 of this Order the weight schedule shall be preserved by the operator of the aircraft until the expiration of a period of 6 months following the next occasion on which the aircraft is weighed for the purposes of this Article.

#### *Access and inspection for airworthiness purposes*

**17** The Minister may cause such inspections, investigations, tests, experiments and flight trials to be made as he deems necessary for the purposes of this Part of this Order and any person authorised to do so in writing by the Minister may at any reasonable time inspect any part of, or material intended to be incorporated in or used in the manufacture of any part of, an aircraft or its equipment or any documents relating thereto and may for that purpose go upon any aerodrome or enter any aircraft factory.

## PART IV

### AIRCRAFT CREW AND LICENSING

#### *Composition of crew of aircraft*

**18** (1) An aircraft shall not fly unless it carries a flight crew of the number and description required by the law of the country in which it is registered.

(2) An aircraft registered in Seychelles shall carry a flight crew adequate in number and description to ensure the safety of the aircraft and of at least the number and description specified in the certificate of airworthiness issued or rendered valid under this Order or, if no certificate of airworthiness is required under this Order to be in force, the certificate of airworthiness, if any, last in force under this Order, in respect of that aircraft.

(3) Unless the Minister otherwise prescribes, a flying machine registered in Seychelles and flying for the purpose of public transport, having a maximum total weight authorised of 5,700 kg. or more, shall carry not less than two pilots as members of the flight crew thereof.

(4) An aircraft registered in Seychelles engaged on a flight for the purpose of public transport shall carry:

- (a) a flight navigator as a member of the flight crew; or
- (b) navigational equipment approved by the Minister and used in accordance with any conditions subject to which that approval may have been given,

if on the route or any diversion therefrom, being a route or diversion planned before take-off, the aircraft is intended to be more than 500 nautical miles from the point of take-off measured along the route to be flown, and to pass over part of an area specified in Schedule 8 to this Order. The flight navigator carried in compliance with this Article shall be carried in addition to any person who is carried in accordance with this Article to perform other duties.

(5) An aircraft registered in Seychelles which is required by the provisions of Article 14 of this Order to be equipped with radio communication apparatus shall carry a flight radio operator as a member of the flight crew, who, if he is required to operate radiotelegraph apparatus, shall be carried in addition to any other person who is carried in accordance with this Article to perform other duties.

(6) If it appears to him to be expedient to do so in the interests of safety, the Minister may direct any particular operator that the aircraft operated by him or any such aircraft shall not fly in such circumstances as the Minister may specify unless those aircraft carry in addition to the flight crew required to be carried therein by the

foregoing provisions of this Article such additional persons as members of the flight crew as he may specify in the direction.

- (7) (a) When an aircraft registered in Seychelles carries 20 or more passengers on a flight for the purposes of public transport, the crew of the aircraft shall include cabin attendants carried for the purposes of performing in the interest of the safety of passengers duties to be assigned by the operator or the person in command of the aircraft, but who shall not act as members of the flight crew.
- (b) The Minister may give a direction to the operator of any aircraft registered in Seychelles requiring him to include among the crew thereof whenever the aircraft is flying for the purpose of public transport at least one cabin attendant, notwithstanding that the aircraft may be carrying fewer than 20 passengers.
- (c) In the case of an aircraft with a total seating capacity of not more than 200, the number of cabin attendants carried on such a flight as is mentioned in sub-paragraph (a) of this Article, shall be not less than one cabin attendant for every 50, or fraction of 50, passengers carried.
- (d) In the case of an aircraft with a total seating capacity of more than 200, the number of cabin attendants carried on such a flight as aforesaid, shall be not less than half the number of main exits in the aircraft, and in addition, when more than 200 passengers are carried, one additional cabin attendant for every 25, or fraction of 25, of such passengers.

Provided that, if the number of cabin attendants, calculated in accordance with this sub-paragraph, exceeds the number of main exits in the aircraft, it shall be sufficient compliance with this Article if the number of cabin attendants carried is equal to the number of main exits in the aircraft.

- (e) For the purposes of this paragraph a main exit means an exit in the side of the aircraft at floor level intended for the disembarkation of passengers whether normally or in an emergency.

*Members of flight crew - requirement of licences*

**19** (1) Subject to the provisions of this Article, a person shall not act as a member of the flight crew of an aircraft registered in Seychelles unless he is the holder of an appropriate licence granted or rendered valid under this Order:

Provided that a person may within Seychelles without being the holder of such a licence -

- (a) act as flight radiotelephony operator if -
  - (i) he does so as the pilot of a glider not flying for the purpose of public transport or aerial work, or as a person being trained in an aircraft registered in Seychelles to perform duties as a member of the flight crew of an aircraft; and
  - (ii) he is authorised to operate the radiotelephony station by the holder of the licence granted in respect of that station under any enactment; and
  - (iii) messages are transmitted only for the purposes of instruction, or of the safety or navigation of the aircraft; and
  - (iv) messages are transmitted only on a frequency exceeding 60 MHz assigned by the Minister for use on flights on which a flight radiotelephony operator acts in one of the capacities specified in paragraph (i) of this proviso; and
  - (v) the transmitter is pre-set to one or more of the frequencies so assigned and cannot be adjusted in flight to any other frequency; and
  - (vi) the operation of the transmitter requires the use only of external switches; and
  - (vii) the stability of the frequency radiated is maintained automatically by the transmitter;
- (b) subject to the provisions of Article 20(8), act as pilot in command of an aircraft for the purpose of becoming qualified for the grant or renewal of a pilot's licence or the inclusion or variation of any rating in a pilot's licence if-
  - (i) he is at least 17 years of age; and
  - (ii) he is the holder of a valid medical certificate to the effect that he is fit to so act by a person approved by the Minister; and
  - (iii) he complies with any conditions subject to which that medical certificate was issued;
  - (iv) no other person is carried in the aircraft; and
  - (v) the aircraft is not flying for the purpose of public transport or aerial work; and



(vi) he so acts in accordance with instructions given by a person holding a pilot's licence granted under this Order being a licence which includes a flying instructor's rating or an assistant flying instructor's rating entitling him to give instruction in flying the type of aircraft being flown.

(2) Subject as aforesaid, a person shall not act as a member of the flight crew required by or under this Order to be carried in an aircraft registered in a country other than Seychelles unless -

- (a) in the case of an aircraft flying for the purpose of public transport or aerial work he is the holder of an appropriate licence granted or rendered valid under the law of the country in which the aircraft is registered; or
- (b) in the case of any other aircraft, he is the holder of an appropriate licence granted or rendered valid under the law of the country in which the aircraft is registered or under this Order, and the Minister does not in the particular case give a direction to the contrary.

(3) For the purposes of this Article, a licence granted under the law of a Contracting State purporting to authorise the holder thereof to act as a member of the flight crew of an aircraft, not being a licence purporting to authorise him to act as a student pilot only, shall, unless the Minister in the particular case gives a direction to the contrary, be deemed to be a licence rendered valid under this Order but shall not entitle the holder to act as a member of the flight crew of any aircraft flying for the purpose of public transport or aerial work or on any flight in respect of which he receives remuneration for his services as a member of the flight crew on any flight.

(4) Notwithstanding the provisions of paragraph (1) of this Article, a person may, unless the certificate of airworthiness in force in respect of the aircraft otherwise requires, act as pilot of an aircraft registered in Seychelles for the purpose of undergoing training or tests for the grant or renewal of a pilot's licence or for the inclusion, renewal or extension of a rating therein without being the holder of an appropriate licence, if the following conditions are complied with:

- (i) no other person shall be carried in the aircraft or in an aircraft being towed thereby except a person carried as a member of the flight crew in compliance with this Order, a person authorised by the Minister to witness the aforesaid training or tests or to conduct the aforesaid tests, or, if the pilot in command of the aircraft is the holder of an appropriate licence, a person carried for the purpose of being trained or tested as a member of the flight crew of an aircraft; and
- (ii) the person acting as the pilot of the aircraft without being the holder of an appropriate licence either -

- (a) within the period of 6 months immediately preceding was serving as a qualified pilot of aircraft in any of the naval, military or air forces of the Republic of Seychelles and his physical condition has not so far as he is aware, so deteriorated during that period as to render him unfit for the licence for which he intends to qualify; or
- (b) holds a pilot's, a flight navigator's or a flight engineer's licence granted under Article 20 of this Order and the purpose of the training or test is to enable him to qualify under this Order for the grant of a pilot's licence or for the inclusion of an additional type in the aircraft rating in his licence and he acts under the supervision of a person who is the holder of an appropriate licence.

(5) Notwithstanding the provisions of paragraph (1) of this Article, a person may act as a member of the flight crew (otherwise than as a pilot) of an aircraft registered in Seychelles for the purposes of undergoing training or tests for the grant or renewal of a flight navigator's, or a flight engineer's licence or for inclusion, renewal or extension of a rating thereon, without being the holder of an appropriate licence if he acts under the supervision and in the presence of another person who is the holder of the type of licence or rating for which the person undergoing the training or tests is being trained or tested.

(6) Notwithstanding the provisions of paragraph (1) of this Article, a person may act as a member of the flight crew of an aircraft registered in Seychelles without being the holder of an appropriate licence if, in so doing, he is acting in the course of his duty as a member of any of the naval, military or air forces of the Republic of Seychelles.

(7) An appropriate licence for the purposes of this Article means a licence which entitles the holder to perform the functions which he undertakes in relation to the aircraft concerned and the flight on which it is engaged.

(8) This Article shall not apply to a person (other than a flight radio operator) by reason of his acting as a member of the flight crew of a glider which is not flying for the purpose of public transport or aerial work.

(9) Notwithstanding anything in this Article -

- (i) the holder of a licence granted or rendered valid under this Order, being a licence endorsed to the effect that the holder does not satisfy in full the relevant international standard, shall not act as a member of the flight crew of an aircraft registered in Seychelles in or over the territory of a Contracting State, except in accordance with permission granted by the competent authorities of that State;

- (ii) the holder of a licence granted or rendered valid under the law of a Contracting State, being a licence endorsed as aforesaid, shall not act as a member of the flight crew of any aircraft in or over Seychelles except in accordance with permission granted by the Minister, whether or not the licence is or is deemed to be rendered valid under this Order.

*Grant, Renewal and Effect of Flight Crew Licences*

- 20** (1) (a) The Minister may grant licences, subject to such conditions as he thinks fit, of any of the classes specified in Part A of Schedule 9 to this Order authorising the holder to act as a member of the flight crew of an aircraft registered in Seychelles, upon his being satisfied that the applicant is a fit person to hold the licence, and is qualified by reason of his knowledge, experience, competence, skill, physical and mental fitness to act in the capacity to which the licence relates, and for that purpose the applicant shall furnish such evidence and undergo such examinations and tests (including in particular medical examinations) as the Minister may require of him.
- (b) A licence of any class shall not be granted to any person who is under the minimum age specified for that class of licence in Part A of the said Schedule.
- (c) A licence granted under this Article shall not be valid unless it bears thereon the ordinary signature of the holder in ink.
- (d) A licence shall, subject to the provisions of Article 58 of this Order, remain in force for the periods indicated in a licence, not exceeding those respectively specified in the said Schedule, and may be renewed by the Minister from time to time upon his being satisfied that the applicant is a fit person and qualified as aforesaid. If no period is indicated in the licence, it shall remain in force, subject as aforesaid, for the lifetime of the holder.

(2) The Minister may include in a licence a rating, subject to such conditions as he thinks fit, of any of the classes specified in Part B of the said Schedule, upon his being satisfied that the applicant is qualified as aforesaid to act in the capacity to which the rating relates, and such rating shall be deemed to form part of the licence.

(3) Subject to any conditions of the licence and to the provisions of this Order, a licence of any class shall entitle the holder to perform the functions specified in respect of that licence in Part A of the said Schedule under the heading "privileges", and a rating of any class shall entitle the holder of the licence in which such rating is included to perform the functions specified in respect of that rating in Part B of the said Schedule.

- (4) (a) Subject to the provisions of subparagraph (c) of this paragraph, the holder of a pilot's licence, or a flight engineer's licence shall not be entitled to exercise the privileges of an aircraft rating contained in the licence on a flight unless the licence bears a valid certificate of test or a valid certificate of experience, which certificate shall in either case be appropriate to the functions he is to perform on that flight in accordance with Part C of the said Schedule and shall otherwise comply with that Part:

Provided that the holder of a Private Pilot's Licence (Balloons and Airships), a Commercial Pilot's Licence (Balloons) or a Commercial Pilot's Licence (Airships) shall be entitled to exercise the privileges of an aircraft rating contained in the licence on a flight when the licence does not bear such a certificate.

- (b) The holder of a flight navigator's licence shall not be entitled to perform functions on a flight to which Article 18(4) of this Order applies unless the licence bears a valid certificate of experience which certificate shall be appropriate to the functions he is to perform on that flight in accordance with Part C of Schedule 9 and shall otherwise comply with that Part.
- (c) In the case of a certificate of test or a certificate of experience issued in accordance with Part C of the said Schedule on or after 10th November 1975 the holder of a Private Pilot's Licence shall not be entitled to exercise the privileges of an aircraft rating contained in the licence on a flight unless the certificate of test or certificate of experience required by subparagraph (a) of this paragraph is included in the personal flying log book required to be kept by him under Article 22 of this Order.

(5) A person shall not be entitled to perform the functions to which an instrument rating (aeroplanes), a flying instructor's rating, an assistant flying instructor's rating or an instrument meteorological conditions rating (aeroplanes) relates unless his licence bears a valid certificate of test which certificate shall be appropriate to the functions to which the rating relates in accordance with Part C of the said Schedule and shall otherwise comply with that Part.

(6) A person who, on the last occasion when he took a test for the purposes of paragraphs (4) or (5) of this Article, failed that test shall not be entitled to fly in the capacity for which that test would have qualified him had he passed it.

- (7) (a) The holder of a licence, other than a flight radiotelephony operator's licence, granted under this Article shall not be entitled to perform any of the functions to which his licence relates unless it includes a valid medical certificate.

- (b) Every applicant for or holder of such a licence shall upon such occasions as the Minister may require submit himself to medical examination by a person approved by the Minister either generally or in a particular case who shall make a report to the Minister in such form as the Minister may require.
  - (c) Where the medical examination referred to in sub-paragraph (b) of this paragraph has been conducted in Seychelles, the Minister or any person approved by him as competent to do so may, on the basis thereof, issue a medical certificate subject to such conditions as he thinks fit to the effect that he has assessed the holder of the licence as fit to perform the functions to which the licence relates. The certificate shall, without prejudice to paragraph (8) of this Article, be valid for such period as is therein specified and shall be deemed to form part of the licence.
  - (d) Where the medical examination is conducted outside Seychelles the person conducting the examination shall, in addition to making a report to the Minister, issue a certificate certifying, if such is, in his opinion, the case, that the holder of the licence is fit to perform the functions to which the licence relates and the said certificate may be deemed by the Minister to be a medical certificate for the purposes of this Article, and if so shall be valid for such period as may be specified therein in writing by the person conducting the examination.
- (8) (a) A person shall not be entitled to act as a member of the flight crew of an aircraft registered in Seychelles if he knows or has reason to believe that his physical or mental condition renders him temporarily or permanently unfit to perform such functions or to act in such capacity.
- (b) Every holder of a medical certificate issued under Article 19 or this Article who -
- (i) suffers any personal injury involving incapacity to undertake his functions as a member of the flight crew; or
  - (ii) suffers any illness involving incapacity to undertake those functions throughout a period of 20 days or more; or
  - (iii) in the case of a woman, has reason to believe that she is pregnant,

shall inform the Minister in writing of such injury, illness or pregnancy, as soon as possible in the case of injury or pregnancy, and as soon as the period of 20 days has elapsed in the case of illness. The medical certificate shall be deemed to be suspended

upon the occurrence of such injury or pregnancy or the elapse of such period of illness, and such suspension shall cease in the case of injury or illness upon the holder being medically examined under arrangements made by the Minister and pronounced fit to resume his functions as a member of the flight crew or upon the Minister exempting, subject to such conditions as he thinks fit, the holder from the requirement of a medical examination, and in the case of pregnancy upon the holder being medically examined under arrangements made by the Minister after the pregnancy has ended and pronounced fit to resume her functions as a member of the flight crew.

(9) Nothing in this Order shall prohibit the holder of a pilot's licence from acting as pilot of an aircraft not exceeding 5,700 kg. maximum total weight authorised when, with the permission of the Minister, he is testing any person for the purposes of paragraphs (1), (2), (4) or (5) of this Article, notwithstanding that the type of aircraft in which the test is conducted is not specified in the aircraft rating included in his licence or that the licence or personal flying log book as the case may be does not include a valid certificate of test or a valid certificate of experience in respect of the type of aircraft.

(10) Where any provision of Part C of Schedule 9 or Part B of Schedule 11 to this Order permits a test to be conducted in a flight simulator approved by the Minister, that approval may be granted subject to such conditions as the Minister thinks fit.

(11) The Minister may prescribe a shorter maximum period of validity for any class of licence mentioned in Part A of Schedule 9 than the maximum period specified in such Schedule and may prescribe a maximum period where none is specified.

#### *Validation of licences*

**21.** The Minister may issue a certificate of validation rendering valid for the purposes of this Order any licence as a member of the flight crew of aircraft granted under the law of any country other than Seychelles. A certificate of validation may be issued subject to such conditions and for such periods as the Minister thinks fit.

#### *Personal flying log book*

**22.** Every member of the flight crew of an aircraft registered in Seychelles and every person who engages in flying for the purpose of qualifying for the grant or renewal of a licence under this Order shall keep a personal flying log book in which the following particulars shall be recorded:

The name and address of the holder of the log book.

Particulars of the holder's licence (if any) to act as a member of the flight crew of an aircraft.

The name and address of his employer (if any).

Particulars of all flights made as a member of the flight crew of an aircraft, including-

- (a) the date, duration and places of arrival and departure of each flight;
- (b) the type and registration marks of the aircraft;
- (c) the capacity in which the holder acted in flight;
- (d) particulars of any special conditions under which the flight was conducted, including night flying and instrument flying;
- (e) particulars of any test or examination undertaken whilst in flight.

Particulars of any test or examination undertaken whilst in a flight simulator, including -

- (a) the date of the test or examination;
- (b) the type of simulator;
- (c) the capacity in which the holder acted;
- (d) the nature of the test or examination.

*Instruction in flying*

**23.** (1) A person shall not give any instruction in flying to any person flying or about to fly a flying machine for the purpose of becoming qualified for -

- (a) the grant of a pilot's licence; or
- (b) the inclusion in a pilot's licence of an aircraft rating entitling the holder of the licence to act as pilot of -
  - (i) a multi-engined aircraft, or
  - (ii) an aircraft of any class appearing in column 4 of the Table in Part A of Schedule 1 to this Order,

if the person under instruction has not been previously entitled under the Order, or qualified in any of the naval, military or air force of the Republic of Seychelles to act as pilot of multi-engined aircraft, or of an aircraft of that class as the case may be; or

- (c) the inclusion or variation of any rating, other than an aircraft rating, in a pilot's licence,

unless :

- (aa) the person giving the instruction holds a licence, granted or rendered valid under this Order, entitling him to act as pilot in

command of the aircraft for the purpose and in the circumstances under which instruction is to be given; and

- (bb) such licence includes a flying instructor's rating or an assistant flying instructor's rating entitling the holder, in accordance with the privileges specified in Schedule 9 to this Order in respect of that rating, to give the instruction; and
- (cc) if consideration is given for the instruction, such licence entitles the holder to act as pilot in command of an aircraft flying for the purpose of public transport:

Provided that sub-paragraph (cc) of this paragraph shall not apply if the aircraft is owned, or is operated under arrangements entered into, by a flying club of which both the person giving and the person receiving the instruction are members.

(2) For the purpose of this Article consideration shall be deemed to be given for instruction if any reward is given or promised by any person to any other person in consideration of the flight being made or of the instruction being given or if the instruction is given by a person employed for reward primarily for the purpose of giving such instruction.

#### *Glider pilot - minimum age*

**24.** A person under the age of 16 years shall not act as pilot in command of a glider.

## PART V

### OPERATION OF AIRCRAFT

#### *Operations Manual*

**25.** (1) This Article shall apply to public transport aircraft registered in Seychelles except aircraft used for the time being solely for flights not intended to exceed 60 minutes in duration, which are either -

- (a) flights solely for training persons to perform duties in an aircraft; or
- (b) flights intended to begin and end at the same aerodrome.

- (2) (a) The operator of every aircraft to which this Article applies shall -
  - (i) make available to each member of his operating staff an operations manual, and
  - (ii) ensure that each copy of the operation manual is kept up to date, and



- (iii) ensure that on each flight every member of the crew has access to a copy of every part of the operations manual which is relevant to his duties on the flight.
- (b) Each operations manual shall contain all such information and instructions as may be necessary to enable the operating staff to perform their duties as such including in particular information and instructions relating to the matters specified in Part A of Schedule 11 to this Order:

Provided that the operations manual shall not be required to contain any information or instructions available in a flight manual accessible to the persons by whom the information or instructions may be required.

- (3) (a) An aircraft to which this Article applies shall not fly unless, not less than 30 days prior to such flight, the operator of the aircraft has furnished to the Minister a copy of the whole of the operations manual for the time being in effect in respect of the aircraft.
- (b) Any amendments or additions to the operations manual shall be furnished to the Minister by the operator before or immediately after they come into effect:

Provided that where an amendment or addition relates to the operation of an aircraft to which the operations manual did not previously relate, that aircraft shall not fly for the purpose of public transport until the amendment or addition has been furnished to the Minister.

- (c) Without prejudice to the foregoing sub-paragraphs the operator shall make such amendments or additions to the operations manual as the Minister may require for the purpose of ensuring the safety of the aircraft or of persons or property carried therein or the safety, efficiency or regularity of air navigation.

(4) For the purposes of this Article and Schedule 11 to this Order "operating staff" means the servants and agents employed by the operator, whether or not as members of the crew of the aircraft, to ensure that the flights of the aircraft are conducted in a safe manner, and includes an operator who himself performs those functions.

(5) If in the course of a flight on which the equipment specified in Scale O in paragraph 5 of Schedule 5 hereto is required to be provided the said equipment becomes unserviceable, the aircraft shall be operated on the remainder of that flight in accordance with any relevant instructions in the operations manual.

*Training manual*

**26.** (1) The operator of every aircraft registered in Seychelles and flying for the purpose of public transport shall:

- (a) make a training manual available to every person appointed by the operator to give or to supervise the training, experience, practice or periodical tests required under Article 27(2) of this Order; and
- (b) ensure that each copy of that training manual is kept up to date.

(2) Each training manual shall contain all such information and instructions as may be necessary to enable a person appointed by the operator to give or to supervise the training, experience, practice and periodical tests required under Article 27(2) of this Order to perform his duties as such including in particular information and instructions relating to the matters specified in Part C of Schedule 11 of this Order.

- (3) (a) An aircraft to which this Article applies shall not fly unless, not less than 30 days prior to such flight, the operator of the aircraft has furnished to the Minister a copy of the whole of his training manual relating to the crew of that aircraft.
- (b) Any amendments or additions to the training manual shall be furnished to the Minister by the operator before or immediately after they come into effect:

Provided that where an amendment or addition relates to training, experience, practice or periodical tests on an aircraft to which the training manual did not previously relate, that aircraft shall not fly for the purpose of public transport until the amendment or addition has been furnished to the Minister.

- (c) Without prejudice to the foregoing sub-paragraphs the operator shall make such amendments or additions to the training manual as the Minister may require for the purpose of ensuring the safety of the aircraft or of persons or property carried therein or the safety, efficiency or regularity of air navigation.

*Public transport - operator's responsibilities*

**27.** (1) The operator of an aircraft registered in Seychelles shall not permit the aircraft to fly for the purpose of public transport without first –

- (a) designating from among the flight crew a pilot to be the commander of the aircraft for the flight; and
- (b) satisfying himself by every reasonable means that the aeronautical radio stations and navigational aids serving the intended route or any planned diversion therefrom are adequate for the safe navigation of the aircraft; and

- (c) satisfying himself by every reasonable means that the aerodromes at which it is intended to take-off or land and any alternate aerodrome at which a landing may be made are suitable for the purpose and in particular are adequately manned and equipped (including such manning and equipment as is specified in Regulation 12 in Schedule 15 to this Order) to ensure the safety of the aircraft and its passengers:

Provided that the operator of the aircraft shall not be required to satisfy himself as to the adequacy of fire-fighting, search, rescue or other services which are required only after the occurrence of an accident.

(2) The operator of an aircraft registered in Seychelles shall not permit any person to be a member of the crew thereof during any flight for the purpose of public transport (except a flight for the sole purpose of training persons to perform duties in aircraft) unless such person has had the training, experience, practice and periodical tests specified in Part B of Schedule 11 to this Order in respect of the duties which he is to perform and unless the operator has satisfied himself that such person is competent to perform his duties, and in particular to use the equipment provided in the aircraft for the purpose. The operator shall maintain, preserve, produce and furnish information respecting records relating to the foregoing matters in accordance with Part B of the said Schedule 11.

(3) The operator of an aircraft registered in Seychelles shall not permit any member of the flight crew thereof, during any flight for the purpose of the public transport of passengers, to simulate emergency manoeuvres and procedures which the operator has reason to believe will adversely affect the flight characteristics of the aircraft.

*Loading - public transport aircraft and suspended loads*

**28.** (1) The operator of an aircraft registered in Seychelles shall not cause or permit it to be loaded for a flight for the purpose of public transport, or any load to be suspended therefrom, except under the supervision of a person whom he has caused to be furnished with written instructions as to the distribution and securing of the load so as to ensure that -

- (a) the load may safely be carried on the flight; and
- (b) any conditions subject to which the certificate of airworthiness in force in respect of the aircraft was issued or rendered valid, being conditions relating to the loading of the aircraft, are complied with.

(2) The instructions shall indicate the weight of the aircraft prepared for service, that is to say the aggregate of the basic weight (shown in the weight schedule referred to in Article 16 of this Order) and the weight of such additional items in or on the aircraft as the operator thinks fit to include: and the instructions shall indicate the

additional items included in the weight of the aircraft prepared for service, and shall show the position of the centre of gravity of the aircraft at that weight:

Provided that this paragraph shall not apply in relation to a flight if -

- (a) the aircraft's maximum total weight authorised does not exceed 1,150 kg; or
- (b) the aircraft's maximum total weight authorised does not exceed 2,730 kg. and the flight is intended not to exceed 60 minutes in duration and is either -
  - (i) a flight solely for training persons to perform duties in an aircraft; or
  - (ii) a flight intended to begin and end at the same aerodrome.

(3) The operator of an aircraft shall not cause or permit it to be loaded in contravention of the instructions referred to in paragraph (1) of this Article.

(4) The person supervising the loading of the aircraft shall, before the commencement of any such flight, prepare and sign a load sheet in duplicate conforming to the requirements specified in Regulation 1 in Schedule 15 to this Order, and shall (unless he is himself the commander of the aircraft) submit the load sheet for examination by the commander of the aircraft who shall sign his name thereon:

Provided that the foregoing requirements of this paragraph shall not apply if -

- (a) the load and the distributing and securing thereof upon the next intended flight are to be unchanged from the previous flight and the commander of the aircraft makes and signs an endorsement to that effect upon the load sheet for the previous flight, indicating the date of the endorsement, the place of departure upon the next intended flight and the next intended place of destination; or
- (b) paragraph (2) of this Article does not apply in relation to the flight.

(5) One copy of the load sheet shall be carried in the aircraft when Article 54 of this Order so requires until the flights to which it relates have been completed and one copy of that load sheet and of the instructions referred to in this Article shall be preserved by the operator until the expiration of a period of 6 months thereafter and shall not be carried in the aircraft.

*Public transport - operating conditions*

**29.** (1) An aircraft registered in Seychelles shall not fly for the purpose of public transport, except for the sole purpose of training persons to perform duties in aircraft,

unless the requirements specified in Regulation 4 in Schedule 15 to this Order in respect of its weight and related performance are complied with.

(2) The assessment of the ability of an aircraft to comply with paragraph (1) of this Article shall be based on the information as to its performance contained in the certificate of airworthiness relating to the aircraft. In the event of the information given therein being insufficient for that purpose such assessment shall be based on the best information available to the commander of the aircraft.

(3) A flying machine registered in Seychelles when flying over water for the purposes of public transport shall fly, except as may be necessary for the purpose of take-off or landing, at such an altitude as would enable the aircraft -

- (a) if it has one engine only, in the event of the failure of that engine;
- (b) if it has more than one engine, in the event of the failure of one of those engines and with the remaining engine or engines operating within the maximum continuous power conditions specified in the certificate of airworthiness relating to the aircraft,

to reach a place at which it can safely land at a height sufficient to enable it to do so.

(4) Without prejudice to the provisions of paragraph (3) of this Article, an aeroplane in respect of which there is in force under this Order a certificate of airworthiness designating the aeroplane as being of performance group X shall not fly over water for the purpose of public transport so as to be more than 60 minutes flying time from the nearest shore, unless the aeroplane has more than two power units. For the purposes of this paragraph, flying time shall be calculated at normal cruising speed with one power unit inoperative.

*Aircraft registered in Seychelles - Aerodrome operating minima*

- 30.** (1) (a) The operator of every aircraft to which Article 25 of this Order applies shall establish and include in the operations manual relating to the aircraft particulars of aerodrome operating minima appropriate to every aerodrome of intended departure or landing and every alternate aerodrome.

Provided that in relation to any flight wherein it is not practicable to include such information in the operations manual the operator of the said aircraft shall, prior to the commencement of the flight, cause to be furnished, in writing, to the commander of the aircraft particulars of the aerodrome operating minima appropriate to every aerodrome of intended departure or landing and every alternate aerodrome and calculated in accordance with the specified method; and the operator shall cause a copy of the said particulars to be retained outside the aircraft for a minimum period of 3 months.

- (b) The operator of every aircraft shall include in the operations manual relating to that aircraft such data and instructions as will enable the commander of the aircraft to calculate aerodrome operating minima appropriate to aerodromes the use of which could not reasonably have been foreseen by the operator prior to the commencement of the flight.

(2) The aerodrome operating minima specified shall not, in respect of any aerodrome, be less favourable than any declared in respect of that aerodrome by the competent authority, unless that authority otherwise permits in writing.

(3) In establishing aerodrome operating minima for the purposes of this Article the operator of the aircraft shall take into account the following matters -

- (a) the type and performance and handling characteristics of the aircraft and any relevant conditions in its certificate of airworthiness; and
- (b) the composition of its crew; and
- (c) the physical characteristics of the relevant aerodrome and its surroundings; and
- (d) the dimensions of the runways which may be selected for use; and
- (e) whether or not there are in use at the relevant aerodrome any aids, visual or otherwise, to assist aircraft in approach, landing or take-off, being aids which the crew of the aircraft are trained and equipped to use; the nature of any such aids that are in use; and the procedures for approach, landing and take-off which may be adopted according to the existence or absence of such aids;

and shall establish in relation to each runway which may be selected for use aerodrome operating minima appropriate to each set of circumstances which can reasonably be expected.

(4) An aircraft to which Article 25 of this Order applies shall not commence a flight at a time when -

- (a) the cloud ceiling or the runway visual range at the aerodrome of departure is less than the relevant minimum specified for take-off; or
- (b) according to the information available to the commander of the aircraft it would not be able, without contravening paragraph (5) of this Article, to commence or continue an approach to landing at the aerodrome of intended destination at the estimated time of arrival there and at any alternate aerodrome at any time at which according to a reasonable estimate the aircraft would arrive there.

- (5) An aircraft to which Article 25 of this Order applies shall not -
- (a) commence or continue an approach to landing at any aerodrome if the runway visual range at that aerodrome is at the time less than the specified minimum for landing: except that an approach to landing may be continued if, when the commander of the aircraft receives information that the runway visual range is less than the specified minimum for landing -
    - (i) the aircraft is below the specified decision height, and
    - (ii) the specified visual reference has been established at the decision height and is maintained; and
    - (iii) the approach to landing has, at least until the specified visual reference has been established, been made by use of an instrument landing system notified for the purpose of this Order; or
  - (b) continue an approach to landing at any aerodrome by flying below the specified decision height unless from that height the specified visual reference for landing is established and is maintained.

(6) If, according to the information available, an aircraft would as regards any flight be required by the Rules of the Air and Air Traffic Control to be flown in accordance with the Instrument Flight Rules at the aerodrome of intended landing, the commander of the aircraft shall select prior to take-off an alternate aerodrome unless no aerodrome suitable for that purpose is available.

(7) In this Article "specified" in relation to an aircraft means specified by the operator in, or ascertainable by reference to, the operations manual relating to that aircraft.

*Aircraft not registered in Seychelles - aerodrome operating minima*

**31.** (1) A public transport aircraft registered in a country other than Seychelles shall not fly in or over the Seychelles unless the operator thereof shall have furnished to the Minister such particulars as he may from time to time have required relating to the aerodrome operating minima specified by the operator in relation to aerodromes in the Seychelles for the purpose of limiting their use by the air-craft for take-off or landing, including any instructions given by the operator in relating to such aerodrome operating minima. The aircraft shall not fly in or over Seychelles unless the operator shall have made such amendments or additions to the aerodrome operating minima so specified and any instructions so given as the Minister may require for the purpose of ensuring the safety of the aircraft or the safety, efficiency or regularity of air navigation.

(2) The aircraft shall not begin or end a flight at an aerodrome in Seychelles in contravention of the aerodrome operating minima so specified in relation to that aerodrome or of the instructions referred to in paragraph (1) of this Article.

(3) Without prejudice to the provisions of paragraph (2) of this Article, a public transport aircraft registered in a country other than Seychelle shall not -

(a) commence or continue an approach to landing at any aerodrome in Seychelles if the runway visual range at that aerodrome is at the time less than the specified minimum for landing: except that an approach to landing may be continued if, when the commander of the aircraft receives information that the runway visual range is less than the special minimum for landing -

(i) the aircraft is below the specified decision height; and

(ii) the specified visual reference has been established at the decision height and is maintained, and

(iii) the approach to landing has, at least until the specified visual reference has been established, been made by use of an instrument landing system notified for the purpose of this Order; or

(b) continue an approach to landing at any aerodrome in Seychelles by flying below the specified decision height unless from that height the specified visual reference is established and is maintained.

(4) In this Article "specified" in relation to an aircraft means specified by the operator in, or ascertainable by reference to, the operations manual relating to that aircraft.

*Pre-flight action by commander of aircraft*

**32.** The commander of an aircraft registered in Seychelles shall satisfy himself before the aircraft takes off -

(a) that the flight can safely be made, taking into account the latest information available as to the route and aerodromes to used, the weather reports and forecasts available, and any alternative course of action which can be adopted in case the flight cannot be completed as planned;

(b) that the equipment (including radio apparatus) required by or under this Order to be carried in the circumstances of the intended flight is carried and is in a fit condition for use;

(c) that the aircraft is in every way fit for the intended flight, and that where certificates of maintenance or certificates of release are required by



Article 9(1) or Article 10(1) respectively of this Order to be in force, they are in force and will not cease to be in force during the intended flight;

- (d) that the load carried by the aircraft is of such weight, and is so distributed and secured, that it may safely be carried on the intended flight;
- (e) in the case of a flying machine or airship, that sufficient fuel, oil and engine coolant (if required) are carried for the intended flight, and that a safe margin has been allowed for contingencies, and, in the case of a flight for the purpose of public transport, that the instructions in the operations manual relating to fuel, oil and engine coolant have been complied with;
- (f) in the case of an airship or balloon, that sufficient ballast is carried for the intended flight;
- (g) in the case of a flying machine, that, having regard to the performance of the flying machine in the conditions to be expected on the intended flight, and to any obstructions at the places of departure and intended destination and on the intended route, it is capable of safely taking off, reaching and maintaining a safe height thereafter, and making a safe landing at the place of intended destination;
- (h) that any pre-flight check system established by the operator and set forth in the operations manual or elsewhere has been complied with by each member of the crew of the aircraft.

*Pilots to remain at controls*

**33.** The commander of an aircraft in Seychelles, being a flying machine or glider, shall cause one pilot to remain at the controls at all times which the aircraft is in flight. If the aircraft is required by or under this Order to carry two pilots, the commander shall cause both pilots to remain at the controls during take-off and landing. If the aircraft carries two or more pilots (whether or not it is required to do so) and is engaged on a flight for the purpose of the public transport of passengers the commander shall remain at the controls during take-off and landing. Each pilot at the controls shall be secured in his seat by either a safety belt or a safety harness except that during take-off and landing a safety harness shall be used if it is required by Article 13 of this Order to be provided.

*Public transport of passengers - duties of commander*

**34.** (1) This Article applies to flights for the purpose of the public transport of passengers by aircraft registered in Seychelles.

(2) In relation to every flight to which this Article applies the commander of the aircraft shall -

- (a) before the aircraft takes off, take all reasonable steps to ensure that all passengers are made familiar with the position and method of

use of emergency exits, safety belts, safety harness, oxygen equipment and lifejackets, and all other devices required by or under this Order and intended for use by passengers individually in case of an emergency occurring to the aircraft:

Provided that in relation to lifejackets this requirement may, except in the case of a seaplane, be complied with at any time before the aircraft reaches a point beyond gliding distance from land;

- (b) if the aircraft is not a seaplane but is intended in the course of the flight to reach a point more than 30 minutes flying time (while flying in still air at the speed specified in the relevant certificate of airworthiness as the speed for compliance with regulations governing flights over water) from the nearest land, take all reasonable steps to ensure that before that point is reached, all passengers are given a practical demonstration of the method of use of the lifejackets required by or under this Order for the use of passengers;
- (c) if the aircraft is a seaplane, take all reasonable steps to ensure that before the aircraft takes off all passengers are given a practical demonstration of the method of use of the equipment referred to in the preceding subparagraph;
- (d) before the aircraft takes off, and before it lands, take all reasonable steps to ensure that the crew of the aircraft are properly secured in their seats and that any persons carried in compliance with Article 18(7) of this Order are properly secured in seats which shall be in a passenger compartment and which shall be so situated that those persons can readily assist passengers;
- (e) before the aircraft takes off, and before it lands, and whenever by reason of turbulent air or any emergency occurring during flight he considers the precaution necessary, take all reasonable steps to ensure that all passengers are properly secured in their seats by safety belts or safety harnesses;
- (f) in an emergency, take all reasonable steps to ensure that all passengers are instructed in the emergency action which they should take;
- (g) except in a case where a pressure greater than 700 millibars is maintained in all passenger and crew compartments throughout the flight, take all reasonable steps to ensure that -
  - (i) before the aircraft reaches flight level 130 the method of use of the oxygen provided in the aircraft in compliance with the

requirements of Article 13 of this Order is demonstrated to all passengers;

- (ii) on reaching such altitude all passengers are recommended to use oxygen;
- (iii) during any continuous period exceeding 30 minutes when the aircraft is flying above flight level 100 but not above flight level 130, and whenever the aircraft is flying above flight level 130, oxygen is used by all the crew of the aircraft.

*Operation of radio in aircraft*

**35.** (1) The radio station in an aircraft shall not be operated, whether or not the aircraft is in flight, except in accordance with the conditions of the licence issued in respect of that station under the law of the country in which the aircraft is registered, and by a person duly licensed or otherwise permitted to operate the radio station under that law.

(2) Whenever an aircraft is in flight in such circumstances that it is required by or under this Order to be equipped with radio communications apparatus, a continuous radio watch shall be maintained by a member of the flight crew listening to the signals transmitted upon the frequency notified, or designated by a message received from an appropriate aeronautical radio station, for use by that aircraft:

Provided that -

- (a) the radio watch may be discontinued or continued on another frequency to the extent that a message as aforesaid so permits; and
- (b) the watch may be kept by a device installed in the aircraft if -
  - (i) the appropriate aeronautical radio station has been informed to that effect and has raised no objection; and
  - (ii) that station is notified, or in the case of a station situated in a country other than Seychelles, otherwise designated as transmitting a signal suitable for that purpose.

(3) The radio station in an aircraft shall not be operated so as to cause interference which impairs the efficiency of aeronautical telecommunications or navigational services, and in particular emissions shall not be made except as follows:

- (a) emissions of the class and frequency for the time being in use, in accordance with general international aeronautical practice, in the airspace in which the aircraft is flying;

- (b) distress, urgency and safety messages and signals, in accordance with general international aeronautical practice;
- (c) messages and signals relating to the flight of the aircraft, in accordance with general international aeronautical practice;
- (d) such public correspondence messages as may be permitted by or under the aircraft radio station licence referred to in paragraph (1) of this Article.

(4) In every aircraft registered in Seychelles which is equipped with radio communication apparatus a telecommunication log book shall be kept in which the following entries shall be made:

- (a) the identification of the aircraft radio station;
- (b) the date and time of the beginning and end of every radio watch maintained in the aircraft and of the frequency on which it was maintained;
- (c) the date and time, and particulars of all messages and signals sent or received, including in particular details of any distress signals or distress messages sent or received;
- (d) particulars of any action taken upon the receipt of a distress signal or distress message;
- (e) particulars of any failure or interruption of radio communications and the cause thereof:

Provided that a telecommunication log book shall not be required to be kept in respect of communication by radiotelephony with a radio station on land or on a ship which provides a radio service for aircraft.

(5) The flight radio operator maintaining radio watch shall sign the entries in the telecommunication log book indicating the times at which he began and ended the maintenance of such watch.

(6) The telecommunication log book shall be preserved by the operator of the aircraft until a date 6 months after the date of the last entry therein.

(7) In any flying machine registered in Seychelles which is engaged on a flight for the purpose of public transport the pilot and the flight engineer (if any) shall not make use of a hand-held microphone (whether for the purpose of radio communication or of intercommunication within the aircraft) whilst the aircraft is flying in controlled airspace below flight level 150 or is taking off or landing.

*Use of flight data recorders and preservation of records*

**36.** (1) On any flight on which a flight data recorder is required by subparagraph 4(5) of Schedule 5 to this Order to be carried in an aeroplane, it shall always be in use from the beginning of the take-off run to the end of the landing run.

(2) The operator of the aeroplane shall at all times, subject to the provisions of Article 57 of this Order, preserve -

- (a) the last 25 hours of recording made by any flight data recorder required by or under this Order to be carried in an aeroplane; and
- (b) a record of not less than one representative flight, that is to say, a recording of a flight made within the last twelve months which includes a take-off, climb, cruise, descent, approach to landing and landing, together with a means of identifying the record with the flight to which it relates;

and shall preserve such records for such period as the Minister may in a particular case direct.

#### *Towing of gliders*

**37.** (1) An aircraft in flight shall not tow a glider unless the certificate of airworthiness issued or rendered valid in respect of the towing aircraft under the law of the country in which that aircraft is registered includes an express provision that it may be used for that purpose.

(2) The length of the combination of towing aircraft, tow rope and glider in flight shall not exceed 150 metres.

(3) The commander of an aircraft which is about to tow a glider shall satisfy himself, before the towing aircraft takes off -

- (a) that the tow rope is in good condition and is of adequate strength for the purpose, and that the combination of towing aircraft and glider is capable of flying in the manner referred to in Article 32(g) of this Order;
- (b) that signals have been agreed and communication established with persons suitably stationed so as to enable the glider to take off safely;
- (c) that emergency signals have been agreed between the commander of the towing aircraft and the commander of the glider, to be used, respectively, by the commander of the towing aircraft to indicate that the tow should immediately be released by the glider, and by the commander of the glider to indicate that the tow cannot be released.

(4) The glider shall be attached to the towing aircraft by means of the tow rope before the aircraft takes off.

*Towing, picking up and raising of persons and articles*

**38.** (1) Subject to the provisions of this Article, an aircraft in flight shall not, by means external to the aircraft, tow any article, other than a glider, or pick up or raise any person, animal or article, unless the certificate of airworthiness issued or rendered valid in respect of that aircraft under the law of the country in which the aircraft is registered includes an express provision that it may be used for that purpose.

(2) An aircraft in flight shall not tow any article, other than a glider, at night or when flight visibility is less than one nautical mile.

(3) The length of the combination of towing aircraft, tow rope, and article in tow, shall not exceed 150 metres.

(4) A helicopter shall not fly at any height over a congested area of a city, town or settlement at any time when any article, person or animal is suspended from the helicopter.

(5) Nothing in this Article shall -

- (a) prohibit the towing in a reasonable manner by an aircraft in flight of any radio aerial, any instrument which is being used for experimental purposes, or any signal, apparatus or article required or permitted by or under this Order to be towed or displayed by an aircraft in flight;
- (b) prohibit the picking up or raising of any person, animal or article in an emergency or for the purpose of saving life;
- (c) apply to any aircraft while it is flying in accordance with the "B Conditions" set forth in Schedule 2 to this Order;
- (d) be taken to permit the towing or picking up of a glider otherwise than in accordance with Article 37 of this Order.

*Dropping of persons and articles*

**39.** (1) Articles and animals (whether or not attached to a parachute) shall not be dropped, or permitted to drop, from an aircraft in flight so as to endanger persons or property.

(2) Articles, animals and persons (whether or not attached to a parachute) shall not be dropped, or permitted to drop, to the surface from an aircraft flying over Seychelles:

Provided that this paragraph shall not apply to the descent of persons by parachute from an aircraft in an emergency, or to the dropping of articles by, or with the authority of, the commander of the aircraft in any of the following circumstances:

- (a) the dropping of articles for the purpose of saving life;
- (b) the jettisoning, in case of emergency, of fuel or other articles in the aircraft;
- (c) the dropping of ballast in the form of fine sand or water;
- (d) the dropping of articles solely for the purpose of navigating the aircraft in accordance with ordinary practice or with the provision of this Order;
- (e) the dropping at an aerodrome in accordance with prescribed regulations of ropes, banners, or similar articles towed by aircraft;
- (f) the dropping of articles for the purposes of agriculture, horticulture, forestry or public health or as a measure against weather conditions, surface icing or oil pollution, or for training for the dropping of articles for any such purposes, if the articles are dropped with the permission of the Minister and in accordance with any conditions subject to which that permission may have been given.

(3) For the purposes of this Article dropping includes projecting and lowering.

(4) Nothing in this Article shall prohibit the lowering of any person, animal or article from a helicopter to the surface, if the certificate of airworthiness issued or rendered valid in respect of the helicopter under the law of the country in which it is registered includes an express provision that it may be used for that purpose.

*Carriage of weapons and of munitions of war*

**40.** (1) An aircraft shall not carry any munitions of war.

(2) It shall be unlawful for any person to take or cause to be taken on board an aircraft, or to deliver or cause to be delivered for carriage thereon, any goods which he knows or has reason to believe or suspect to be munitions of war.

(3) For the purposes of this Article "munitions of war" means such weapons and ammunition as are designed for use in warfare including parts for such weapons and ammunition.

(4) Without prejudice to paragraphs (1) and (2) of this Article, it shall be unlawful for a person to carry or have in his charge any weapon on board an aircraft registered in Seychelles.

Provided that a weapon, not being a munition of war, may be carried as passenger's baggage if it is stowed in a part of the aircraft inaccessible to passengers and if, in the case of a firearm, it is not loaded.

(5) Nothing in this Article shall apply to weapons or ammunition taken or carried on board an aircraft registered in a country other than Seychelles if the weapons or ammunition, as the case may be, may under the law of the country in which the aircraft is registered be lawfully taken or carried on board for the purpose of ensuring the safety of the aircraft or of persons on board.

*Carriage of dangerous goods*

**41.** (1) Dangerous goods shall not be carried in an aircraft except as follows:

- (a) goods carried in accordance with any regulations which the Minister may make to permit dangerous goods to be carried either in aircraft generally or in aircraft of any class specified in the regulations;
- (b) goods carried with the written permission of the Minister, and in accordance with any conditions to which such permission may be subject;
- (c) goods carried in aircraft with the consent of the operator thereof for the purpose of ensuring the proper navigation or safety of the aircraft or the well-being of any person on board;
- (d) goods permitted to be carried under the laws of the country in which the aircraft is registered if there is in force in relation to such country an agreement between the Government of Seychelles and the Government of that country permitting the carriage of dangerous goods within Seychelles in aircraft registered in that country.

(2) Dangerous goods permitted by or under this Order to be carried in an aircraft shall not be loaded as cargo therein unless –

- (a) the consignor of the goods has furnished the operator of the aircraft with particulars in writing of the nature of the goods and the danger to which they give rise; and
- (b) the goods or any container in which they are packed are clearly marked so as to indicate that danger to the person loading the goods in the aircraft.

The operator of the aircraft shall, before the flight begins, inform the commander of the aircraft of the identify of the goods, the danger to which they give rise and the weight or quantity of the goods.



(3) It shall be unlawful for any person to take or cause to be taken on board an aircraft, or to deliver or cause to be delivered for loading thereon, any goods which he knows or has reason to believe or suspect to be dangerous goods the carriage of which is prohibited by this Article.

(4) The provisions of this Article shall be additional to and not in derogation from the provisions of Article 40 of this Order.

*Method of carriage of persons*

**42.** A person shall not be in or on any part of an aircraft in flight which is not a part designed for the accommodation of persons and in particular a person shall not be on the wings or undercarriage of an aircraft. A person shall not be in or on any object, other than a glider or flying machine, towed by or attached to an aircraft in flight:

Provided that a person may have temporary access to -

- (a) any part of an aircraft for the purpose of taking action necessary for the safety of the aircraft or of any person, animal or goods therein;
- (b) any part of an aircraft in which cargo or stores are carried, being a part which is designed to enable a person to have access thereto while the aircraft is in flight.

*Exits and break-in markings*

**43.** (1) This Article shall apply to every public transport aircraft registered in Seychelles.

(2) Whenever an aircraft to which this Article applies is carrying passengers, every exit therefrom and every internal door in the aircraft shall be in working order, and during take-off and landing and during any emergency, every such exit and door shall be kept free of obstruction and shall not be fastened by locking or otherwise so as to prevent, hinder or delay its use by passengers:

Provided that -

- (a) an exit may be obstructed by cargo if it is an exit which, in accordance with arrangements approved by the Minister either generally or in relation to a class of aircraft or a particular aircraft, is not required for use by passengers;
- (b) a door between the flight crew compartment and any adjacent compartment to which passengers have access may be locked or bolted if the commander of the aircraft so determines, for the purpose of preventing access by passengers to the flight crew compartment;

- (c) nothing in this paragraph shall apply to any internal door which is so placed that it cannot prevent, hinder or delay the exit of passengers from the aircraft in an emergency if it is not in working order.

(3) Every exit from the aircraft being an exit intended to be used by passengers in normal circumstances, shall be marked with the word "Exit" in capital letters and every exit, being an exit intended to be used by passengers in an emergency only, shall be marked with the words "Emergency Exit" in capital letters.

- (4) (a) Every exit from the aircraft shall be marked with instructions in English and with diagrams, to indicate the correct method of opening the exit.

- (b) The markings shall be placed on or near the inside surface of the door or other closure of the exit and, if it is openable from the outside of the aircraft, on or near the exterior surface.

- (5) (a) Every aircraft to which this Article applies, being an aircraft of which the maximum total weight authorised exceeds 3,600 kg., shall be marked upon the exterior surface of its fuselage with markings to show the areas (in this paragraph referred to as "break-in areas") which can, for purposes of rescue in an emergency, be most readily and effectively broken into by persons outside the aircraft.

- (b) The break-in areas shall be rectangular in shape and shall be marked by right-angled corner markings, each arm of which shall be 10 centimetres in length along its outer edge and 2.5 centimetres in width.

- (c) The words "Cut Here in Emergency" shall be marked across the centre of each break-in area in capital letters.

- (6) The markings required by this Article shall -

- (a) be painted, or affixed by other equally permanent means;

- (b) be red in colour and, in any case in which the colour of the adjacent background is such as to render red markings not readily visible, be outlined in white or some other contrast- ing colour in such a manner as to render them readily visible;

- (c) be kept at all times clean and unobscured.

(7) If one, but not more than one, exit from an aircraft becomes inoperative at a place where it is not reasonably practicable for it to be repaired or replaced, nothing in

this Article shall prevent that aircraft from carrying passengers until it next lands at a place where the exit can be repaired or replaced:

Provided that -

- (a) the number of passengers carried and the position of the seats which they occupy is in accordance with arrangements approved by the Minister either in relation to the particular aircraft or to a class of aircraft; and
- (b) in accordance with arrangements so approved, the exit is fastened by locking or otherwise, the words "Exit" or "Emergency Exit" are covered, and the exit is marked by a red disc at least 23 centimetres in diameter with a horizontal white bar across it bearing the words "No exit" in red letters.

*Imperilling safety of aircraft*

**44.** A person shall not wilfully or negligently act in a manner likely to endanger an aircraft, or any person therein.

*Imperilling safety of any person or property*

**45.** A person shall not wilfully or negligently cause or permit an aircraft to endanger any person or property.

*Drunkness in aircraft*

**46.** (1) A person shall not enter any aircraft when drunk, or be drunk in air aircraft.

(2) A person shall not, when acting as a member of the crew of any aircraft or being carried in any aircraft for the purpose of so acting, be under the influence of drink or a drug to such an extent as to impair his capacity so to act.

*Smoking in aircraft*

**47.** (1) Notices indicating when smoking is prohibited shall be exhibited in every aircraft registered in Seychelles so as to be visible from each passenger seat therein.

(2) A person shall not smoke in any compartment of an aircraft registered in Seychelles at any time when smoking is prohibited in that compartment by a notice to that effect exhibited by or on behalf of the commander of the aircraft.

*Authority of commander of aircraft*

**48.** Every person in an aircraft registered in Seychelles shall obey all lawful commands which the commander of that aircraft may give for the purpose of securing

the safety of the aircraft and of persons or property carried therein, or the safety, efficiency or regularity of air navigation.

*Stowaways*

**49.** A person shall not secrete himself for the purpose of being carried in an aircraft without the consent of either the operator or the commander thereof or of any other person entitled to give consent to his being carried in the aircraft.

PART VI

FATIGUE OF CREW

*Application and interpretation of Part VI*

**50.** (1) Articles 51 and 52 of this Order apply in relation to any aircraft registered in Seychelles which is either:-

- (a) engaged on a flight for the purpose of public transport, or
- (b) operated by an air transport undertaking:

Provided that the said Articles shall not apply in relation to a flight made only for the purpose of instruction in flying given by or on behalf of a flying club or flying school, or a person who is not an air transport undertaking.

(2) In this Part of this Order, the following expressions shall, except where the context otherwise requires, have the meanings hereby respectively assigned to them, that is to say -

- (a) "flight time", in relation to any person, means all time spent by that person in an aircraft whether or not registered in Seychelles (other than an aircraft of which the maximum total weight authorised does not exceed 1,600 kg. and which is not flying for the purpose of public transport or aerial work) while it is in flight and he is carried therein as a member of the crew thereof;
- (b) "day" means a continuous period of 24 hours beginning at midnight Greenwich Mean Time.

*Fatigue of crew - operator's responsibilities*

**51.** (1) The operator of an aircraft to which this Articles applies shall not cause or permit that aircraft to make a flight unless:

- (a) he has established a scheme for the regulation of flight times for every person flying in that aircraft as a member of its crew; and

- (b) the scheme is approved by the Minister subject to such conditions as he thinks fit; and
- (c) either -
  - (i) the scheme is incorporated in the operations manual required by Article 25 of this Order; or
  - (ii) in a case where an operations manual is not required by that Article, the scheme is incorporated in a document, a copy of which has been made available to every person flying in that aircraft as a member of its crew; and
- (d) he has taken all such steps as are reasonably practicable to ensure that the provisions of the scheme will be complied with in relation to every person flying in that aircraft as a member of its crew.

(2) The operator of an aircraft to which this Article applies shall not cause or permit any person to fly therein as a member of its crew if he knows or has reason to believe that that person is suffering from, or, having regard to the circumstances of the flight to be undertaken, is likely to suffer from, such fatigue while he is so flying as may endanger the safety of the aircraft or of its occupants.

(3) The operator of an aircraft to which this Article applies shall not cause or permit any person to fly therein as a member of its flight crew unless the operator has in his possession an accurate and up-to-date record in respect of that person and in respect of the 28 days immediately preceding the flight showing -

- (a) all his flight times; and
- (b) brief particulars of the nature of the functions performed by him in the course of his flight times.

(4) The record referred to in paragraph (3) of this Article shall, subject to the provisions of Article 57, be preserved by the operator of the aircraft until a date 12 months after the flight referred to in that paragraph.

*Fatigue of crew - responsibilities of crew*

**52.** (1) A person shall not act as a member of the crew of an aircraft to which this Article applies if he knows or has reason to believe that he is suffering from, or, having regard to the circumstances of the flight to be undertaken, is likely to suffer from, such fatigue as may endanger the safety of the aircraft or of its occupants.

(2) A person shall not act as a member of the flight crew of an aircraft to which this Article applies unless he has ensured that the operator of the aircraft is aware of his flight times during the period of 28 days preceding the flight.

*Flight times - responsibilities of flight crew*

**53.** A person shall not act as a member of the flight crew of an aircraft registered in Seychelles if at the beginning of the flight the aggregate of all his previous flight times:-

- (a) during the period of 28 consecutive days expiring at the end of the day on which the flight begins exceeds 100 hours; or
- (b) during the period of 12 months expiring at the end of the previous month exceeds 900 hours.

*Provided that this Article shall not apply to a flight made -*

- (i) in an aircraft of which the maximum total weight authorised does not exceed 1,600 kg. and which is not flying for the purposes of public transport or aerial work; or
- (ii) in an aircraft not flying for the purpose of public transport nor operated by an air transport undertaking, if at the time when the flight begins the aggregate of all the flight times of the aforesaid person since he was last medically examined and found fit by a person approved by the Minister for the purpose of Article 20(7) does not exceed 25 hours.

## PART VII

### DOCUMENTS AND RECORDS

*Documents to be carried*

**54.** (1) An aircraft shall not fly unless it carries the documents which it is required to carry under the law of the country in which it is registered.

(2) An aircraft registered in Seychelles shall, when in flight, carry documents in accordance with Schedule 12 to this Order:

Provided that, if the flight is intended to begin and end at the same aerodrome and does not include passage over the territory of any country other than Seychelles, the documents may be kept at that aerodrome instead of being carried in the aircraft.

*Records to be kept*

**55.** The operator of a public transport aircraft registered in Seychelles shall in respect of any flight by that aircraft during which it may fly at an altitude of more than 49,000 feet, keep a record in a manner prescribed by the Minister of the total dose of cosmic radiation to which the aircraft is exposed during the flight together with the names of the members of the crew of the aircraft during the flight.

*Production of documents and records*

**56.** (1) The commander of an aircraft, shall within a reasonable time after being requested to do so by an authorised person, cause to be produced to that person -

- (a) the certificates of registration and airworthiness in force in respect of the aircraft;
- (b) the licences of its flight crew;
- (c) such other documents as the aircraft is required by Article 54 of this Order to carry when in flight.

(2) The operator of an aircraft registered in Seychelles shall, within a reasonable time after being requested to do so by an authorised person, cause to be produced to that person such of the following documents or records as may have been requested by that person being documents or records which are required, by or under this Order, to be in force or to be carried, preserved or made available:

- (a) the documents referred to in Schedule 12 to this Order as Documents A, B and G;
- (b) the aircraft log book, engine log books and variable pitch propeller log books required under this Order to be kept;
- (c) the weight schedule, if any, required to be preserved under Article 16 of this Order;
- (d) in the case of a public transport aircraft or aerial work aircraft, the documents referred to in Schedule 12 to this Order as Documents D, E, F, H and J;
- (e) any records which he is required by Article 51(4) of this Order to preserve, and such other documents and information in the possession or control of the operator, as the authorised person may require for the purpose of determining whether those records are complete and accurate;
- (f) any such operations manuals as are required to be made available under Article 25(2)(a)(i) of this Order;
- (g) the record made by any flight recorder required to be carried by or under this Order;
- (h) the record made from any cosmic radiation detection equipment together with the record of the names of the members of the crew of the aircraft which are required to be kept under Article 55 of this Order.

(3) The holder of a licence granted or rendered valid under this Order shall, within a reasonable time after being requested to do so by an authorised person, cause to be produced to that person his licence, including any certificate of validation. The requirements of this paragraph shall be deemed to have been complied with, except in relation to licences required by Article 54 of this Order to be carried in the aircraft or kept at an aerodrome, if the licence requested is produced within five days after the request has been made at a police station in Seychelles specified, at the time of the request, by the person to whom the request is made. The foregoing provisions of this paragraph shall apply to a medical certificate issued pursuant to Article 19(1)(b)(ii) as they apply to a licence granted or rendered valid under this Order.

(4) Every person required by Article 22 of this Order to keep a personal flying log book shall cause it to be produced within a reasonable time to an authorised person after being requested to do so by him within two years after the date of the last entry therein.

*Preservation of documents, etc.*

**57.** A person required by this Order to preserve any document or record by reason of his being the operator of an aircraft shall, if he ceases to be the operator of the aircraft, continue to preserve the document or record as if he had not ceased to be the operator, and in the event of his death the duty to preserve the document or record shall fall upon his personal representative:

Provided that if -

- (a) another person becomes the operator of the aircraft and it remains registered in Seychelles he or his personal representative shall deliver to that other person upon demand the certificates of maintenance, release and compliance, the log books and the weight schedule and any record made by a flight data recorder and preserved in accordance with Article 36(2) of this Order which are in force or required to be preserved in respect of that aircraft;
- (b) an engine or variable pitch propeller is removed from the aircraft and installed in another aircraft operated by another person and registered in Seychelles he or his personal representative shall deliver to that other person upon demand the log book relating to that engine or propeller;
- (c) any person in respect of whom a record has been kept by him in accordance with Article 51 of this Order becomes a member of the flight crew of a public transport aircraft registered in Seychelles and operated by another person he or his personal representative shall deliver those records to that other person upon demand,

and it shall be the duty of that other person to deal with the document or record delivered to him as if he were the first-mentioned operator.



*Revocation, suspension and variation of certificates, licences and other documents*

**58.** (1) The Minister may, if he thinks fit, provisionally suspend or vary any certificate, licence, approval, permission, exemption or other document issued, granted or having effect under this Order, pending inquiry into or consideration of the case. The Minister may, on sufficient ground being shown to his satisfaction after due inquiry, revoke, suspend or vary any such certificate, licence, approval, permission, exemption or other document.

(2) The holder or any person having the possession or custody of any certificate, licence, approval, permission, exemption or other document which has been revoked, suspended or varied under this Order shall surrender it to the Minister within a reasonable time after being required to do so by him.

(3) The breach of any condition subject to which any certificate, licence, approval, permission, exemption or other document, other than a licence issued in respect of an aerodrome, has been granted or issued, or which has effect under this Order shall, in the absence of provision to the contrary in the document, render the document invalid during the continuance of the breach.

(4) Notwithstanding paragraph (1) of this Article, a flight manual, performance schedule or other document incorporated by reference in the certificate of airworthiness may be varied on sufficient ground being shown to the satisfaction of the Minister, whether or not after due inquiry.

*Offences in relation to documents and records*

**59.** (1) A person shall not with intent to deceive -

- (a) use any certificate, licence, approval, permission, exemption or other document issued or required by or under this Order which has been forged, altered, revoked or suspended, or to which he is not entitled; or
- (b) lend any certificate, licence, approval, permission, exemption or other document issued or having effect or required by or under this Order to, or allow it to be used by, any other person; or
- (c) make any false representation for the purpose of procuring for himself or any other person the grant, issue, renewal or variation of any such certificate, licence, approval, permission or exemption or other document.

(2) A person shall not wilfully mutilate, alter or render illegible any log book or other record required by or under this Order to be maintained or any entry made therein, or knowingly make, or procure or assist in the making of, any false entry in or material omission from any such log book or record or destroy any such log book or record during the period for which it is required under this Order to be preserved.

(3) All entries made in writing in any log book or record referred to in paragraph (2) of this Article shall be made in ink or indelible pencil.

(4) A person shall not wilfully or negligently make in a load sheet any entry which is incorrect in any material particular, or any material omission from such a load sheet.

(5) A person shall not purport to issue any certificate for the purposes of this Order or the regulations made thereunder unless he is authorised to do so under this Order.

(6) A person shall not issue any such certificate as aforesaid unless he has satisfied himself that all statements in the certificate are correct.

## PART VIII

### CONTROL OF AIR TRAFFIC

#### *Rules of the air and air traffic control*

**60.** (1) Every person and every aircraft shall comply with such of the Rules of the Air and Air Traffic Control contained in Schedule 14 to this Order as may be applicable to that person or aircraft in the circumstances of the case.

(2) Subject to the provisions of paragraph (3) of this Article, it shall be an offence to contravene, to permit the contravention of, or to fail to comply with, the Rules of the Air and Air Traffic Control.

(3) It shall be lawful for the Rules of the Air and Air Traffic Control to be departed from to the extent necessary -

- (a) for avoiding immediate danger; or
- (b) for complying with the law of any country other than Seychelles within which the aircraft then is.

(4) If any departure from the Rules of the Air and Air Traffic Control is made for the purpose of avoiding immediate danger, the commander of the aircraft shall cause written particulars of the departure, and of the circumstances giving rise to it, to be given within ten days thereafter to the competent authority of the country in whose territory the departure was made or if the departure was made over the high seas, to the Minister.

(5) Nothing in the Rules of the Air and Air Traffic Control shall exonerate any person from the consequences of any neglect in the use of lights or signals or of the neglect of any precautions required by ordinary aviation practice or by the special circumstances of the case.

*Licensing of air traffic controllers and student air traffic controllers*

**61.** (1) The Minister may grant a licence subject to such conditions as he thinks fit to any person to act as an air traffic controller, or as a student air traffic controller, upon his being satisfied that the applicant is a fit person to hold the licence and is qualified by reason of his knowledge, experience, competence, skill, physical and mental fitness so to act, and for that purpose the applicant shall furnish such evidence and undergo such examinations and tests (including in particular medical examinations) as the Minister may require of him:

Provided that the Minister shall not grant -

- (a) a student air traffic controller's licence to a person under the age of 18 years; or
- (b) an air traffic controller's licence which includes an Aerodrome Control Rating, an Approach Control Rating or an Area Control Rating, to a person under the age of 20 years; or
- (c) an air traffic controller's licence which includes any other rating, to a person under the age of 21 years.

(2) Every licence to act as an air traffic controller shall include (a) ratings of one or more of the classes set forth in Schedule 10 to this Order specifying the type of air traffic control service which the holder of the licence is competent to provide, (b) a list of the places at which, and (c) the type of radar equipment, if any, with the aid of which he may provide the service. If throughout any period of 90 days the holder of the licence has not at any time provided at a particular place the type of air traffic control service specified in the rating, the rating shall, without prejudice to the Minister's powers under Article 58 of this Order, cease to be valid for that place at the end of that period, and upon a rating ceasing to be valid for a place the holder of the licence shall forthwith inform the Minister to that effect and shall forward the licence to the Minister to enable it to be endorsed accordingly.

(3) Every licence to act as a student air traffic controller shall be valid only for the purpose of authorising the holder to provide air traffic control service under the supervision of another person who is present at the time and is the holder of a valid air traffic controller's licence which includes a rating specifying the type of air traffic control service which is being provided by the student air traffic controller and valid at the place in question.

(4) A licence to act as an air traffic controller or as a student air traffic controller shall not be valid unless the holder of the licence has signed his name thereon in ink with his ordinary signature.

(5) Subject to the provisions of Article 58 of this Order, a licence to act as an air traffic controller or as a student air traffic controller shall remain in force for the period indicated in the licence, being a period not exceeding five years, and may be

renewed by the Minister from time to time, upon his being satisfied that the applicant is a fit person and is qualified as aforesaid.

(6) Every applicant for and holder of an air traffic controller's licence or a student air traffic controller's licence shall upon such occasions as the Minister may require submit himself to medical examination by a person approved by the Minister either generally or in a particular case who shall make a report to the Minister in such form as the Minister may require.

(7) On the basis of the medical examination referred to in paragraph (6) of this Article, the Minister or any person approved by him as competent to do so may issue a medical certificate subject to such conditions as he thinks fit to the effect that the holder of the licence has been assessed as fit to perform the functions to which the licence relates. The certificate shall, without prejudice to Article 63 of this Order, be valid for such period as is therein specified, and shall be deemed to form part of the licence.

(8) The holder of an air traffic controller's licence or student air traffic controller's licence shall not provide any type of air traffic control service at any such aerodrome or place as is referred to in Article 62(1) of this Order unless his licence includes a medical certificate issued and in force under paragraph (7) of this Article.

*Prohibition of unlicensed air traffic controllers*

**62.** (1) A person shall not provide any type of air traffic control service at any aerodrome at which air traffic control service is required to be provided by or under the Rules of the Air and Air Traffic Control or at any Government aerodrome or at any other place (not being an aerodrome) at which air traffic control service is provided (whether or not under the direction of the Minister or a visiting force) unless he does so under and in accordance with the terms of:

- (a) a valid student air traffic controller's licence granted under this Order and he is supervised in accordance with Article 61(3) of this Order; or
- (b) a valid air traffic controller's licence so granted authorising him to provide that type of service at that aerodrome or other place; or
- (c) a valid air traffic controller's licence so granted which does not authorise him to provide that type of service at the aerodrome or other place, but he is supervised by a person who is present at the time and who is the holder of a valid air traffic controller's licence so granted which authorises him to provide at that aerodrome or other place the type of air traffic control service which is being provided; or
- (d) his appointment by the Minister as an air traffic control officer cadet and he is supervised by a person who is present at the time and who

is the holder of a valid air traffic controller's licence so granted which authorised him to provide that type of service at a Government aerodrome or at a place at which air traffic control service is provided under the direction of the Minister.

Provided that a licence shall not be required by any person who acts in the course of his duty as a member of any of naval, military or air forces of the Republic of Seychelles or a visiting force.

(2) The holder of a licence shall not be entitled to perform any of the functions specified in Schedule 10 to this Order in respect of a rating at any of the places referred to in paragraph (1) of this Article unless:

- (a) his licence includes that rating and the rating is valid for the place at which, and the type of radar equipment, if any, with the aid of which, the functions are performed, or
- (b) he is supervised by a person who is present at the time and who is the holder of a valid air traffic controller's licence granted under this Order which authorises him to provide at that aerodrome or other place the type of air traffic control service which is being provided.

(3) Nothing in a licence granted under Article 61 of this Order shall permit any person to operate manually any direction-finding equipment for the purpose of providing air traffic control service to an aircraft at a time when he is providing air traffic control service or making signals to that aircraft or to another aircraft.

(4) Nothing in this Article shall prohibit the holder of a valid air traffic controller's licence from providing at any place for which the licence includes a valid rating, information to aircraft in flight in the interests of safety.

#### *Incapacity of air traffic controllers*

**63.** (1) Every holder of an air traffic controller's licence granted under Article 61 of this Order who -

- (a) suffers any personal injury or illness involving incapacity to undertake the functions to which his licence relates throughout a period of 20 consecutive days; or
- (b) in the case of a woman, has reason to believe that she is pregnant,

shall inform the Minister in writing of such injury, illness or pregnancy as soon as possible.

(2) An air traffic controller's licence shall be deemed to be suspended upon the elapse of such period of injury or illness as is referred to in paragraph (1)(a) of this Article. The suspension of the licence shall cease:

- (a) upon the holder being medically examined under arrangements made by the Minister and pronounced fit to resume his functions under the licence; or
- (b) upon the Minister exempting the holder from the requirement of a medical examination subject to such conditions as the Minister may think fit.

(3) Upon the pregnancy of the holder of an air traffic controller's licence being confirmed, the licence shall be deemed to be suspended and shall remain suspended until she has been medically examined under arrangements made by the Minister after the pregnancy has ended and pronounced fit to resume her functions under the licence.

*Power to prohibit or restrict flying*

**64.** (1) Where the President deems it necessary in the public interest to restrict or prohibit flying over any area of Seychelles or along any route therein by reason of -

- (a) the intended gathering or movement of a large number of persons,
- (b) the intended holding of an aircraft race or contest or of an exhibition of flying, or
- (c) national defence or any other reason affecting the public interest,

the President may make regulations prohibiting, restricting or imposing conditions on flight, either generally or in relation to any class of aircraft, over any such area or along any such route, and an aircraft shall not fly in contravention of such regulations.

(2) If the commander of an aircraft becomes aware that the aircraft is flying in contravention of any such regulations which have been made for any of the reasons referred to in paragraph (1)(c) of this Article he shall forthwith cause a signal of distress to be made by radio or by one of the prescribed visual signals, and shall (unless otherwise instructed by the appropriate air traffic control unit) cause the aircraft to land at the aerodrome, being an aerodrome suitable for that purpose, which it can reach by flying to the least possible extent over the area to which the regulations relate. The aircraft shall not begin to descend while over such area.

*Balloons, kites and airships*

**65.** (1) Within Seychelles -

- (a) a captive balloon or kite shall not be flown at a height of more than 60 metres above the ground level or within 60 metres of any vessel, vehicle or structure;

- (b) a captive balloon shall not be flown within 5 kilometres of an aerodrome;
- (c) a balloon exceeding 2 metres in any linear dimension at any stage of its flight, including any basket or other equipment attached to the balloon, shall not be flown in controlled airspace;
- (d) a kite shall not be flown within 5 kilometres of an aerodrome;
- (e) an airship shall not be moored,

without the permission in writing of the Minister and in accordance with any conditions subject to which that permission may be granted.

(2) A captive balloon when in flight shall be securely moored, and shall not be left unattended unless it is fitted with a device which ensures its automatic deflation if it breaks free of its moorings.

## PART IX

### AERODROMES, AERONAUTICAL LIGHTS AND DANGEROUS LIGHTS

#### *Aerodromes: public transport of passengers and instruction in flying*

**66.** (1) An aircraft to which this paragraph applies shall not take-off or land at a place in Seychelles other than -

- (a) an aerodrome licensed under this Order for the take-off and landing of such aircraft; or
- (b) a Government aerodrome notified as available for the take-off and landing of such aircraft, or in respect of which the person in charge of the aerodrome has given his permission for the particular aircraft to take-off or land as the case may be,

and in accordance with any condition subject to which the aerodrome may have been so licensed or notified, or subject to which such permission may have been given.

(2) Paragraph (1) of this Article applies to -

- (a) aeroplanes of which the maximum total weight authorised exceeds 2730 kg. and which are flying for the purpose of the public transport of passengers or for the purpose of instruction in flying;
- (b) aeroplanes of which the maximum total weight authorised does not exceed 2730 kg. engaged on either -

- (i) scheduled journeys for the purpose of the public transport of passengers; or
  - (ii) flights for the purpose of the public transport of passengers beginning and ending at the same aerodrome; or
  - (iii) flights for the purpose of instruction in flying; or
  - (iv) flights for the purpose of the public transport of passengers at night;
- (c) helicopters and gyroplanes engaged on such flights as are specified in sub-paragraphs (i), (ii) and (iii) above;
- (d) gliders (other than gliders being flown under arrangements made by a flying club and carrying no person other than a member of the club) which are flying for the purpose of the public transport of passengers or for the purpose of instruction in flying.
- (3) (a) The person in charge of any area in Seychelles intended to be used for the taking-off or landing of helicopters at night other than such a place as is specified in paragraph (1) of this Article shall cause to be in operation, whenever a helicopter flying for the purpose of public transport of passengers is taking-off or landing at that area by night, such lighting as will enable the pilot of the helicopter -
- (i) in the case of landing, to identify the landing area in flight, to determine the landing direction and to make a safe approach and landing;
  - (ii) in the case of taking-off, to make a safe take-off.
- (b) a helicopter flying for the purpose of the public transport of passengers at night shall not take-off or land at a place to which sub-paragraph (a) of this paragraph applies unless there is in operation such lighting.

*Use of Government aerodromes*

**67.** The Minister may cause to be notified subject to such conditions as he thinks fit any Government aerodrome as an aerodrome available for the take-off and landing of aircraft engaged on flights for the purpose of the public transport of passengers or for the purpose of instruction in flying or of any classes of such aircraft.

*Licensing of aerodromes*

**68.** (1) The Minister may license any aerodromes in Seychelles subject to such conditions as he thinks fit, for the take-off and landing of aircraft engaged in flights for



the purpose of the public transport of passengers, or for the purpose of instruction in flying, or of any classes of such aircraft.

(2) Without prejudice to the generality of paragraph (1) of this Article, if the person applying for the licence so requests, the Minister may grant a licence (in this Order referred to as "a licence for public use") which shall be subject to the condition that the aerodrome shall at all times when it is available for the take-off or landing of aircraft be so available to all persons on equal terms and conditions.

(3) The licensee of an aerodrome in respect of which a licence for public use is in force shall display in a prominent place at the aerodrome a copy of the licence and shall furnish to any person on request information concerning the terms of the licence.

(4) The licensee of an aerodrome licensed under this Order shall not cause or permit any condition of the licence to be contravened, in relation to an aircraft engaged on a flight for the public transport of passengers or for instruction in flying, but the licence shall not cease to be valid by reason only of such a contravention.

(5) A licence granted by the Minister in respect of an aerodrome shall, subject to the provisions of Article 58 of this Order, remain in force for such period as may be specified in the licence.

#### *Radio equipment at aerodrome*

**69.** (1) This Article shall apply to all aerodromes licensed under this Order (other than aerodromes at which an air traffic control service is provided by the Minister) used for the taking off or landing of aircraft of which the maximum total weight authorised exceeds 2730 kg. and which are engaged on flights for the purpose of the public transport of passengers.

(2) Any radar or radio navigation equipment used to facilitate an aircraft's approach to land and landing at an aerodrome to which this Article applies, shall be -

- (a) approved by the Minister as suitable for the service to be provided;
- (b) installed and maintained in a manner approved by the Minister;
- (c) flight checked, overhauled, repaired or modified only by, or under the supervision of a person approved by the Minister.

#### *Records at aerodromes*

**70.** (1) The licensee of an aerodrome to which Article 69 applies, shall -

- (a) keep a written record in respect of each installation of radar or radio navigation equipment provided by him and used to facilitate an aircraft's approach to land and landing at the aerodrome, which record shall include particulars of functional tests and flight checks

of the equipment as well as the particulars of any overhaul, repair, replacement or modification thereof;

- (b) preserve the written record for a period of one year or such longer period as the Minister may in a particular case direct, and shall within a reasonable time after being requested to do so by an authorised person, produce such record to that person.

(2) The licensee of every aerodrome licensed under this Order which is provided with means of two-way radio communication with aircraft and either with radar equipment or with very high frequency direction finding apparatus for the purpose of providing holding aid, let-down aid or approach aid, shall provide at the aerodrome apparatus which is capable of recording the terms or content of any radio message or signal transmitted to any aircraft (either alone or in common with other aircraft) or received from any aircraft, by the air traffic control unit at the aerodrome.

(3) The apparatus provided in compliance with paragraph (2) of this Article shall -

- (a) be of a type approved by the Minister in relation to the aerodrome; and
- (b) be installed in a manner so approved; and
- (c) always be maintained in serviceable condition; and
- (d) be in use at all times when any navigation services are being provided by the air traffic control unit at the aerodrome to any aircraft flying for the purpose of the public transport of passengers.

(4) The licensee of the aerodrome shall ensure that each record made by the apparatus provided in compliance with paragraph (2) of this Article includes -

- (a) the date or dates on which the record was made;
- (b) a means of identifying the person at the aerodrome by whom the message or signal was transmitted, the aircraft to or from which and the frequency on which the message or signal was transmitted or received, and the time at which each message or signal transmitted from the aerodrome was transmitted;
- (c) the time (if any) at which the radio station at the aerodrome opened or closed as the case may be within the period covered by each such record.

(5) If at any time the apparatus provided in compliance with paragraph (2) of this Article ceases to be capable of recording the matters required by this Article to be

included in the record, the licensee of the aerodrome shall ensure that those matters are recorded in writing.

(6) The licensee of the aerodrome shall preserve any record made in compliance with paragraph (2) of this Article for a period of 30 days or such other period as may be prescribed from the date on which the message or signal was recorded or for such longer period as the Minister may in a particular case direct, and shall, within a reasonable time after being requested to do so by an authorised person, produce such record to that person.

(7) A person required by this Article to preserve any record by reason of his being the licensee of an aerodrome shall, if he ceases to be the licensee of the aerodrome, continue to preserve the record as if he had not ceased to be licensee, and in the event of his death the duty to preserve the record shall fall upon his personal representative:

Provided that if another person becomes the licensee of the aerodrome he or his personal representative shall deliver the record to that other person on demand, and it shall be the duty of that other person to deal with the record delivered to him as if he were the first mentioned licensee.

#### *Charges at aerodromes licensed for public use*

**71.** (1) The Minister may, in relation to any aerodrome in respect of which a licence for public use has been granted, or to such aerodromes generally or to any class thereof, prescribe the charges, or the maximum charges, which may be made for the use of the aerodrome and for any services performed at the aerodrome to or in connection with aircraft, and may further prescribe the conditions to be observed in relation to those charges and the performance of those services.

(2) The licensee of an aerodrome in relation to which the Minister has made any regulations under paragraph (1) of this Article shall not cause or permit any charges to be made in contravention of those regulations and shall cause particulars of the prescribed charges to be kept exhibited at the aerodrome in such a place and manner as to be readily available for the information of any person affected thereby.

(3) The licensee of any aerodrome in respect of which a licence for public use has been granted shall, when required by the Minister, furnish to the Minister such particulars as he may require of the charges established by the licensee for the use of the aerodrome or of any facilities provided at the aerodrome for the safety, efficiency or regularity of air navigation.

#### *Use of aerodromes by aircraft of Contracting States and of the Commonwealth*

**72.** The person in charge of any aerodrome in Seychelles which is open to public use by aircraft registered in Seychelles (whether or not the aerodrome is a licensed aerodrome) shall cause the aerodrome, and all air navigation facilities provided thereat, to be available for use by aircraft registered in other Contracting States or in any part of

the Commonwealth on the same terms and conditions as for use by aircraft registered in Seychelles.

*Noise and vibration caused by aircraft on aerodromes*

**73.** The conditions under which noise and vibration may be caused by aircraft (including military aircraft) on Government aerodromes, aerodromes owned or managed by the Minister, licensed aerodromes or on aerodromes at which the manufacture, repair or maintenance of aircraft is carried out by persons carrying on business as manufacturers or repairers of aircraft shall be as specified in Regulation 9 in Schedule 15 to this Order, and section 41(2) of the Act, as set out in the Schedule of the Civil Aviation Act 1949 (Overseas Territories) Order 1969 (a), shall apply to any such aerodrome.

*Aeronautical lights*

**74.** (1) A person shall not establish or maintain an aeronautical light within Seychelles except with the permission of the Minister and in accordance with any conditions which may be prescribed, or subject to which the permission may be granted.

(2) A person shall not alter the character of an aeronautical light within Seychelles except with the permission of the Minister and in accordance with any conditions subject to which the permission may be granted.

(3) In the case of an aeronautical light, being a beacon, which is or may be visible from any waters within an area of a general light-house authority, the Minister shall not give his permission for the purpose of this Article except with the consent of that authority.

(4) A person shall not wilfully or negligently injure or interfere with any aeronautical light established and maintained by, or with the permission of, the Minister.

*Dangerous lights*

**75.** (1) A person shall not exhibit in Seychelles any light which -

- (a) by reason of its glare is liable to endanger aircraft taking off from or landing at an aerodrome; or
- (b) by reason of its liability to be mistaken for an aeronautical light is liable to endanger aircraft.

(2) If any light which appears to the Minister to be such a light as aforesaid is exhibited the Minister may cause a notice to be served upon the person who is the occupier of the place where the light is exhibited or having charge of the light, directing that person, within a reasonable time to be specified in the notice, to take such steps as

may be specified in the notice for extinguishing or screening the light and for preventing for the future the exhibition of any other light which may similarly endanger aircraft.

(3) The notice may be served either personally or by post, or by affixing it in some conspicuous place near to the light to which it relates.

(4) In the case of a light which is or may be visible from any waters within the area of a lighthouse authority, the powers of the Minister under this Article shall not be exercised except with the consent of that authority.

#### *Customs airports*

**76.** (1) The Minister may, subject to such conditions as he may think fit, by order designate any aerodrome to be a place for the landing or departure of aircraft for the purpose of the enactments for the time being in force relating to customs.

(2) The Minister may by order revoke any designation so made.

## PART X

### GENERAL

#### *Prohibited Areas*

**77.** (1) The President may by proclamation declare any specifically defined area in Seychelles to be a prohibited area.

(2) Except as may be provided in the proclamation whereby the prohibited area is established, or in any subsequent proclamation issued by the President, no aircraft shall fly over, or land in, any prohibited area.

#### *Restriction with respect to aerial photography and survey from aircraft registered outside the Territory*

**78.** An aircraft registered in a Contracting State other than Seychelles or in a foreign country, shall not fly over Seychelles for the purpose of aerial photography or aerial survey except with the permission of the Minister granted under this Article to the operator or the charterer of the aircraft and in accordance with any conditions to which such permission may be subject.

#### *Mandatory reporting*

**79.** (1) Subject to the provisions of this Article, every person who -

- (a) is the operator or the commander of a public transport aircraft which is registered in Seychelles and has a maximum total weight authorised of more than 2,300 kg; or

- (b) carries on the business of manufacturing, repairing or overhauling such an aircraft, or any equipment or part thereof; or
- (c) signs a certificate of maintenance, release or compliance in respect of such an aircraft, part or equipment; or
- (d) performs a function for which he requires an air traffic controller's licence; or
- (e) is the licensee or manager of a licensed aerodrome,

shall -

- (i) make a report to the Minister of any reportable occurrence of which he knows and which is of such a description as is specified in Regulation 14 in Schedule 15 to this Order. The report shall be made within such time, by such means, and shall contain such information as is so specified and it shall be presented in such form as the Minister may in any particular case approve, and
- (ii) make a report to the Minister, within such time, by such means, and containing such information as the Minister may specify in a notice in writing served upon him, being information which is in his possession or control and which relates to a reportable occurrence which has been reported by him or by another person to the Minister in accordance with this Article.

(2) In this Article "reportable occurrence" means -

- (a) any incident relating to such an aircraft or any defect in or malfunctioning of such an aircraft or any part or equipment of such an aircraft, being an incident, malfunctioning or defect endangering, or which if not corrected would endanger, the aircraft, its occupants, or any other person;
- (b) any defect in or malfunctioning of any facility on the ground used or intended to be used for purposes of or in connection with the operation of such an aircraft, being a defect or malfunctioning endangering, or which if not corrected would endanger, such an aircraft or its occupants:

Provided that any accident notified in pursuance of regulations made under section 10 of the Act as set out in the Schedule of the Civil Aviation Act (Overseas Territories) Order 1969(a) shall not constitute a reportable occurrence for purposes of this Article.

(3) Subject to paragraph (1)(ii) of this Article, nothing in this Article shall require a person to report any occurrence which he has reason to believe has been or will be reported by another person to the Minister in accordance with this Article.

(4) A person shall not make any report under this Article if he knows or has reason to believe that the report is false in any particular.

(5) Without prejudice to Article 36(2) and subject to the provisions of Article 57 of this Order, the operator of an aircraft shall, if he has reason to believe that a report has been or will be made in pursuance of this Article, preserve any data from a flight data recorder relevant to the reportable occurrence for fourteen days from the date on which a report of that occurrence is made to the Minister or for such longer period as the Minister may in a particular case direct:

Provided that the record may be erased if the aircraft is outside the Seychelles and it is not reasonably practicable to preserve the record until the aircraft reaches Seychelles.

#### *Power to prevent aircraft flying*

**80.** (1) If it appears to the Minister or an authorised person that any aircraft is intended or likely to be flown -

- (a) in such circumstances that any provision of Articles 3, 5, 6, 7, 18, 19, 28, 36 or 40 of this Order would be contravened in relation to the flight; or
- (b) in such circumstances that the flight would be in contravention of any other provision of this Order or any regulations made thereunder and be a cause of danger to any person or property whether or not in the aircraft; or
- (c) while in a condition unfit for the flight, whether or not the flight would otherwise be in contravention of any provision of this Order or of any regulation made thereunder,

the Minister or that authorised person may direct the operator or the commander of the aircraft that he is not to permit the aircraft to make the particular flight or any other flight of such description as may be specified in the direction, until the direction has been revoked by the Minister or by an authorised person, and the Minister or that authorised person may take such steps as are necessary to detain the aircraft.

(2) For the purposes of paragraph (1) of this Article the Minister or any authorised person may enter upon and inspect any aircraft.

(3) If it appears to the Minister or an authorised person that any aircraft is intended or likely to be flown in such circumstances that any provision of Article 77 or 78 of this Order or any provision relating to the licensing of air transport in Seychelles

would be contravened in relation to the flight, the Minister or that authorised person may direct the operator or the commander of the aircraft that he is not to permit the aircraft to make the particular flight or any other flight of such description as may be specified in the direction until the direction has been revoked by the Minister or by an authorised person, and the Minister or any authorised person may take such steps as are necessary to detain the aircraft.

(4) For the purposes of paragraph (3) of this Article the Minister or any authorised person may enter upon any aerodrome and may enter upon and inspect any aircraft.

**81.** The President, the Minister and any authorised person shall have the right of access at all reasonable times -

- (a) to any aerodrome, for the purpose of inspecting the aerodrome, or
- (b) to any aerodrome for the purpose of inspecting any aircraft on the aerodrome or any document which the President, the Minister or the authorised person has power to demand under this Order, or for the purpose of detaining any aircraft under the provisions of this Order; and
- (c) to any place where an aircraft has landed, for the purpose of inspecting the aircraft or any document which the President, the Minister or the authorised person has power to demand under this Order and for the purpose of detaining the aircraft under the provisions of this Order:

Provided that access to a Government aerodrome shall only be obtained with the permission of the person in charge of the aerodrome.

#### *Obstruction of persons*

**82.** A person shall not wilfully obstruct or impede any person acting in the exercise of his powers or the performance of his duties under this Order.

#### *Enforcement of directions*

**83.** Any person who fails to comply with any direction given to him under any provision of this Order or any regulations made thereunder shall be deemed for the purposes of this Order to have contravened that provision.

#### *Penalties*

**84.** (1) If any provision of this Order or of any regulations made thereunder is contravened in relation to an aircraft, the operator of that aircraft and the commander thereof, shall (without prejudice to the liability of any other person under this Order for that contravention) be deemed for the purposes of the following provisions of this Article to have contravened that provision unless he proves that the contravention



occurred without his consent or connivance and that he exercised all due diligence to prevent the contravention.

(2) If it is proved that an act or omission of any person which would otherwise have been a contravention by that person of a provision of this Order or of any regulations made thereunder was due to any cause not avoidable by the exercise of reasonable care by that person the act or omission shall be deemed not to be a contravention by that person of that provision.

(3) Where a person is charged with contravening a provision of this Order or of any regulations made thereunder by reason of his having been a member of the flight crew of an aircraft on a flight for the purpose of public transport or aerial work the flight shall be treated (without prejudice to the liability of any other person under this Order) as not having been for that purpose if he proves that he neither knew nor had reason to know that the flight was for that purpose.

(4) If any person contravenes any provision of this Order, or of any regulations made thereunder, not being a provision referred to in paragraphs (5) or (6) of this Article, he shall be liable on summary conviction, to a fine not exceeding £100; or in the case of a second or subsequent conviction for the like offence to a fine not exceeding £200.

(5) If any person contravenes any provision specified in Part A of Schedule 13 to this Order he shall be liable on summary conviction to a fine not exceeding £200, or in the case of a second or subsequent conviction for the like offence to a fine not exceeding £500; and on conviction on indictment to a fine not exceeding £500 or imprisonment for a term not exceeding 6 months.

(6) If any person contravenes any provision specified in Part B of the said Schedule he shall be liable on summary conviction to a fine not exceeding £1,000 and on conviction on indictment to a fine or imprisonment for a term not exceeding two years or both.

#### *Extra-territorial effect of the Order*

**85.** Except where the context otherwise requires, the provisions of this Order,

- (a) in so far as they apply (whether by express reference or otherwise) to aircraft registered in Seychelles, shall apply to such aircraft wherever they may be;
- (b) in so far as they apply as aforesaid to other aircraft shall apply to such aircraft when they are within Seychelles;
- (c) in so far as they prohibit, require or regulate (whether by express reference or otherwise) the doing of anything by persons in, or by any of the crew of, any aircraft registered in Seychelles, shall apply to such persons and crew, wherever they may be; and

- (d) in so far as they prohibit, require or regulate as aforesaid the doing of anything in relation to any aircraft registered in Seychelles by other persons shall, where such persons are citizens of Seychelles, apply to them wherever they may be.

*Application of Order to Seychelles-controlled aircraft not registered in Seychelles*

**86.** The President may direct that such of the provisions of this Order and of any regulations made or having effect thereunder as may be specified in the direction shall have effect as if reference in those provisions to aircraft registered in Seychelles included references to the aircraft specified in the direction, being an aircraft not so registered but for the time being under the management of a person who, or of persons each of whom, is qualified to hold a legal or beneficial interest by way of ownership in an aircraft registered in Seychelles.

*Exemption from Order*

**87.** The Minister may exempt from any of the provisions of this Order (other than Articles 78 and 88 thereof) or any regulations made thereunder, any aircraft or persons or classes of aircraft or persons, either absolutely or subject to such conditions as he thinks fit.

*Appeal to Court*

**88.** (1) Subject to paragraph (2) of this Article, an appeal shall lie to the Supreme Court or to such other court as may be prescribed from any decision of the Minister that a person is not a fit person to hold a licence to act as an aircraft maintenance engineer, member of the flight crew of an aircraft, air traffic controller or student air traffic controller, and if the court is satisfied that on the evidence submitted to the Minister he was wrong in so deciding, the court may reverse the Minister's decision:

Provided that an appeal shall not lie from a decision of the Minister that a person is not qualified to hold the licence by reason of a deficiency in his knowledge, experience, competence, skill, physical or mental fitness.

(2) The respondent to any appeal under this Article shall be the Attorney-General.

*Regulations by the Minister : Fees*

**89.** (1) The Minister may make regulations for prescribing anything which, under the provision of this Order, is to be prescribed.

(2) Without prejudice to the generality of paragraph (1) of this Article, such Regulations may prescribe the fees to be charged in connection with the issue, validation, renewal, extension or variation of any certificate, licence or other document (including the issue of a copy thereof), or the undergoing of any examination, test,

inspection or investigation or the grant of any permission or approval, required by, or for the purpose of, this Order or any regulations made thereunder.

(3) Upon an application being made in connection with which any fee is chargeable in accordance with the said provisions the applicant may be required before the application is entertained to pay the whole or to deposit a portion of the fee or fees so chargeable. If, after such payment or deposit has been made, the application is withdrawn by the applicant or otherwise ceases to have effect or is refused by the Minister, the Minister may, subject as hereinafter provided, refund the amount of such payment or deposit. Where the amount paid or deposited is wholly or to any extent attributable to a fee chargeable in respect of an investigation which would have been carried out in connection with the application if it had not been so withdrawn or ceased to have effect or been refused but which has not been carried out by reason only of such withdrawal, cesser or refusal, the Minister may refund the amount so attributable or, in a case where an investigation has been partially completed, so much of that amount as in the opinion of the Minister is reasonable having regard to the stage to which the investigation has progressed at the time of such withdrawal, cesser or refusal:

Provided that, if in any case the amount deposited by the applicant is not sufficient to cover the fee, as ultimately assessed, chargeable in respect of any investigation in so far as the same has been carried out at the time when the application is withdrawn by him or otherwise ceases to have effect or is refused by the Minister the amount representing the balance of such fee shall be payable by the applicant.

In this paragraph the expression "investigation" includes an inspection, examination, calculation or test.

#### *Interpretation*

**90.** (1) In this Order, unless the context requires -

"The Act" means the Civil Aviation Act 1949(a);

"Aerial work" means any purpose (other than public transport) for which an aircraft is flown if hire or reward is given or promised in respect of the flight or the purpose of the flight;

"Aerial work aircraft" means an aircraft (other than a public transport aircraft) flying, or intended by the operator to fly, for the purpose of aerial work;

"Aerial work undertaking" means an undertaking whose business includes the performance of aerial work;

"Aerobatic manoeuvres" includes loops, spins, rolls, bunts, stall turns, inverted flying and any other similar manoeuvre;

"Aerodrome" means any area of land or water designed, equipped, set apart or commonly used for affording facilities for the landing and departure of aircraft and

includes any area or space, whether on the ground, on the roof of a building or elsewhere, which is designed, equipped or set apart for affording facilities for the landing and departure of aircraft capable of descending or climbing vertically, but shall not include any area the use of which for affording facilities for the landing and departure of aircraft has been abandoned and has not been resumed;

"Aerodrome operating minima" in relation to the operation of an aircraft at an aerodrome means the cloud ceiling and runway visual range for take-off, and the decision height, runway visual range and visual reference for landing, specified by the operator in, or ascertainable by reference to, the operations manual as being the minima for the operation of that aircraft at that aerodrome;

"Aerodrome traffic zone" in relation to any aerodrome means the airspace extending from the surface to a height of 2,000 feet above the level of the aerodrome and within a distance of 1½ nautical miles of its boundaries except any part of that airspace which is within the aerodrome traffic zone of another aerodrome which is notified for the purposes of this Order as being the controlling aerodrome.

"Aeronautical light" means any light established for the purpose of aiding air navigation;

"Aeronautical radio station" means a radio station on the surface, which transmits or receives signals for the purpose of assisting aircraft;

"Air traffic control unit" means a person appointed by the Minister or by any other person maintaining an aerodrome or place to give instructions or advice or both instructions and advice by means of radio signals to aircraft in the interests of safety and "Air traffic control service" shall be construed accordingly;

"Air transport undertaking" means an undertaking whose business includes the carriage by air of passengers or cargo for hire or reward;

"Approach to landing" means that portion of the flight of the aircraft in which it is descending below a height of 1000 feet above the decision height of the relevant minimum for landing;

"Appropriate aeronautical radio station" means in relation to an aircraft an aeronautical radio station serving the area in which the aircraft is for the time being;

"Appropriate air traffic control unit" means in relation to an aircraft the air traffic control unit serving the area in which the aircraft is for the time being;

"Authorised person" means any person authorised by the Minister either generally or in relation to a particular case or class of cases, and references to a person authorised by the Minister include references to the holder for the time being of any office designated by the Minister.

"Beneficial interest" includes interests arising under contract and other equitable interests;

"Cargo" includes mail and animals;

"Certificate of airworthiness" includes any validation thereof and any flight manual, performance schedule or other document, whatever its title, incorporated by reference in that certificate relating to the certificate of airworthiness;

"Certificate of maintenance", "certificate of release" and "certificate of compliance" have the meanings respectively assigned to them by Articles 9(1), 10(1) and 11(4) of this Order;

"the Civil Aviation Authority" refers to the Directorate of Civil Aviation of the Republic of Seychelles;

"Cloud ceiling" in relation to an aerodrome means the vertical distance from the elevation of the aerodrome to the lowest part of any cloud visible from the aerodrome which is sufficient to obscure more than one-half of the sky so visible;

"Commander" in relation to an aircraft means the member of the flight crew designated as commander of that aircraft by the operator thereof, or, failing such a person, the person who is for the time being the pilot in command of the aircraft;

"Competent authority" means in relation to Seychelles, the Minister and in relation to any other country the authority responsible under the law of that country for promoting the safety of civil aviation;

"Congested area" in relation to a city, town or settlement, means any area which is substantially used for residential, industrial, commercial or recreational purposes;

"Contracting State" means any State (including the Seychelles) which is a party to the Convention on International Civil Aviation signed at Chicago on the 7th December, 1944;

"Controlled airspace" means control areas and control zones;

"Control area" means airspace which has been notified as such and which extends upwards from a notified altitude;

"Control zone" means airspace which has been notified as such and which extends upwards from the surface;

"Co-pilot" in relation to an aircraft means a pilot who in performing his duties as such is subject to the direction of another pilot carried in the aircraft;

"Crew" has the meaning assigned to it by paragraph (4) of this Article;

"Decision height" in relation to the operation of an aircraft at an aerodrome means the minimum height specified by the operator in, or ascertainable by reference to, the operations manual as being the minimum height to which an approach to landing can safely be made by that aircraft at that aerodrome without visual reference to the ground;

"Flight" and "to fly" have the meanings respectively assigned to them by paragraph (3) of this Article;

"Flight crew" in relation to an aircraft means those members of the crew of the aircraft who respectively undertake to act as pilot, flight navigator, flight engineer and flight radio operator of the aircraft;

"Flight level" means one of a series of levels of equal atmospheric pressure, separated by notified intervals and each expressed as the number of hundreds of feet which would be indicated at that level on a pressure altimeter calibrated in accordance with the International Standard Atmosphere and set to 1013.2 millibars;

"Flight simulator" means apparatus by means of which flight conditions in an aircraft are simulated on the ground;

"Flight visibility" means the visibility forward from the flight deck of an aircraft in flight;

"Government aerodrome" means any aerodrome in Seychelles which is under the control of the Minister or is in the occupation of any Government Department or visiting force;

"Instrument Flight Rules" means Instrument Flight Rules contained in the Rules of the Air and Air Traffic Control;

"Instrument Meteorological Conditions" means weather precluding flight in compliance with the Visual Flight Rules;

"International Headquarters" means an international headquarters designated by Order in Council under section 1 of the International Headquarters and Defence Organisations Act 1964(a) as extended to Seychelles;

"To land" in relation to aircraft includes alighting on the water;

"Legal personal representative" means the executor, administrator or other representative of a deceased person;

"Licence" includes any certificate of competency or certificate of validity issued with the licence or required to be held in connection with the licence by the law of the country in which the licence is granted;

"Licence for public use" has the meaning assigned to it by Article 68(2) of this Order;

"Licensed aerodrome" means an aerodrome licensed under this Order;

"Lifejacket" includes any device designed to support a person individually in or on the water;

"Log book" in the case of an aircraft log book, engine log book or variable pitch propeller log book, includes a record kept either in a book, or by any other means approved by the Minister in the particular case;

"Maximum total weight authorised" in relation to an aircraft means the maximum total weight of the aircraft and its contents at which the aircraft may take off anywhere in the world, in the most favourable circumstances in accordance with the certificate of airworthiness in force in respect of the aircraft;

"Military aircraft" includes the naval, military or air force aircraft of any country and-

- (a) any aircraft being constructed for the naval, military or air forces of any country under a contract entered into by the Minister; and
- (b) any aircraft in respect of which there is in force a certificate issued by the Minister that the aircraft is to be treated for the purposes of this Order as a military aircraft;

"Nautical mile" means the International Nautical Mile, that is to say, a distance of 1852 metres;

"Navigation services" includes information, directions and other facilities furnished, issued or provided for the purposes of or in connection with the navigation or movement of aircraft;

"Night" means the time between half an hour after sunset and half an hour before sunrise, sunset and sunrise being determined at surface level;

"Notified" means shown in any of the following publications issued in Seychelles whether before or after the coming into operation of this Order, that is to say, "Notams (Notices to Airmen)", "Information Circulars", or such other official publication so issued for the purpose of enabling any of the provisions of this Order to be complied with;

"Operator" has the meaning assigned to it by paragraph (5) of this Article;

"Pilot in command" in relation to an aircraft means a person who for the time being is in charge of the piloting of the aircraft without being under the direction of any other pilot in the aircraft;

"Prescribed" means prescribed by regulations made by the Minister under this Order, and the expression "prescribe" shall be construed accordingly;

"Pressurised aircraft" means an aircraft provided with means of maintaining in any compartment a pressure greater than that of the surrounding atmosphere;

"Public transport" has the meaning assigned to it by paragraph (6) of this Article;

"Public transport aircraft" means an aircraft flying, or intended by the operator of the aircraft to fly, for the purpose of public transport;

"Record" includes, in addition to a record in writing -

- (a) any disc, tape, sound-track or other device in which sounds or signals are embodied so as to be capable (with or without the aid of some other instrument) of being reproduced therefrom;
- (b) any film, tape or other device in which visual images are embodied so as to be capable (as aforesaid) of being reproduced therefrom; and
- (c) any photograph;

and any reference to a copy of a record includes, in the case of a record falling within paragraph (a) only of this definition, a transcript of the sounds or signals embodied therein, in the case of a record falling within paragraph (b) only of this definition, a still reproduction of the images embodied therein, and in the case of a record falling within both those paragraphs, such a transcript together with such a still reproduction;

"Replacement" in relation to any part of an aircraft or its equipment includes the removal and replacement of that part whether or not by the same part, and whether or not any work is done on it, but does not include the removal and replacement of a part which is designed to be removable solely for the purpose of enabling another part to be inspected, repaired, removed or replaced or cargo to be loaded;

"Rules of the Air and Air Traffic Control" means the Rules contained in Schedule 14 of this Order;

"Runway visual range" in relation to a runway or landing strip means the maximum distance in the direction of take-off or landing, as the case may be, at which the runway or landing strip or the markers or lights delineating it can be seen from a point 5 metres above its centre line; and in the case of an aerodrome in Seychelles the distance, if any, communicated to the commander of the aircraft by or on behalf of the person in charge of the aerodrome as being the runway visual range shall be taken to be the runway visual range for the time being;

"Scheduled journey" means one of a series of journeys which are undertaken between the same two places and which together amount to a systematic service;

"Seaplane" includes a flying boat and any other aircraft designed to manoeuvre on the water;



"Special VFR flight" means a flight which is a special VFR flight for the purposes of the Rules of the Air and Air Traffic Control;

"Visual Flight Rules" means Visual Flight Rules contained in the Rules of the Air and Air Traffic Control;

"Visual Meteorological Conditions" means weather permitting flight in accordance with the Visual Flight Rules.

(2) In this Order references to sums expressed in terms of sterling shall be construed as references to the equivalent sums in the currency of Seychelles calculated at such rate of exchange as may be determined by the Central Bank of Seychelles from time to time for buying sterling;

(3) An aircraft shall be deemed to be in flight -

- (a) in the case of a piloted flying machine, from the moment when, after the embarkation of its crew for the purpose of taking off, it first moves under its own power, until the moment when it next comes to rest after landing;
- (b) in the case of a pilotless flying machine, or a glider, from the moment when it first moves for the purpose of taking off until the moment when it next comes to rest after landing;
- (c) in the case of an airship or free balloon, from the moment when it first becomes detached from the surface until the moment when it next becomes attached thereto or comes to rest thereon;

and the expressions "a flight" and "to fly" shall be construed accordingly.

(4) Every person employed or engaged in an aircraft in flight on the business of the aircraft shall be deemed to be a member of the crew thereof.

(5) References in this Order to the operator of an aircraft are, for the purpose of the application of any provision of this Order in relation to any particular aircraft, references to the person who at the relevant time has the management of that aircraft, and cognate expressions shall be construed accordingly:

Provided that for the purposes of the application of any provision in Part III of this Order, when by virtue of any charter or other agreement for the hire or loan of an aircraft a person other than an air transport undertaking or an aerial work undertaking has the management of that aircraft for a period not exceeding 14 days, the foregoing provisions of this paragraph shall have effect as if that agreement had not been entered into.

- (6) (a) Subject to the provisions of this paragraph, an aircraft in flight shall for the purposes of this Order be deemed to fly for the purpose of public transport -
- (i) if hire or reward is given or promised for the carriage of passengers or cargo in the aircraft on that flight; or
  - (ii) if any passengers or cargo are carried gratuitously in the aircraft on that flight by an air transport undertaking, not being persons in the employment of the undertaking (including, in the case of a body corporate, its directors), persons with the authority of the Minister either making any inspection or witnessing any training, practice or test for the purposes of this Order, or cargo intended to be used by any such passengers as aforesaid, or by the undertaking; or
  - (iii) for the purposes of Part III of this Order, if hire or reward is given or promised for the right to fly the aircraft on that flight (not being a single-seater aircraft of which the maximum total weight authorised does not exceed 910 kg. and in respect of which a certificate of airworthiness of the Special Category is in force) otherwise than under a hire-purchase agreement;

and the expression "public transport of passengers" shall be construed accordingly:

Provided that, notwithstanding that an aircraft may be flying for the purpose of public transport by reason of sub-paragraph (a) (iii) of this paragraph it shall not be deemed to be flying for the purpose of the public transport of passengers unless hire or reward is given for the carriage of those passengers.

- (b) Where under a transaction effected by or on behalf of a member of an association of persons on the one hand and the association of persons or any member thereof on the other hand, a person is carried, or is given the right to fly, an aircraft in such circumstances that hire or reward would be given or promised if the transaction were effected otherwise than aforesaid, hire or reward shall, for the purposes of this Order, be deemed to have been given or promised notwithstanding any rule of law as to such transactions.

(7) The expressions appearing in the "General Classification of Aircraft" set forth in Part A of Schedule 1 to this Order shall have the meanings thereby assigned to them.

(8) The Interpretation Act 1889 of the United Kingdom applies for the purpose of the interpretation of this Order and otherwise in relation thereto as it applies for the purpose of the interpretation of and in relation to, an Act of Parliament of the United Kingdom, and as if this Order were such an Act of Parliament.

(9) A power to make regulations under this Order shall include the power to make different provisions with respect to different classes of aircraft, aerodromes, persons or property and with respect to different circumstances and with respect to different parts of Seychelles and to make such incidental and supplementary provisions as are necessary or expedient for carrying out the purposes of the Order.

(10) Unless the context otherwise requires any references in the Order to any Act of Parliament shall be construed as a reference to that Act as amended, extended or applied by or under any other Act.

(11) (a) Any power conferred by this Order to issue, make, serve or grant any instrument shall be construed as including a power exercisable in the like manner and subject to the like conditions, if any, to vary, revoke, cancel or otherwise terminate the instrument.

(b) In this paragraph "instrument" includes any regulation, direction, instruction, rule or other requirement, any notice and any certificate, licence, approval, permission, exemption, log book record or other document.

*Saving*

**91.** Subject to the provisions of Articles 68 and 72 of this Order, nothing in this Order or the regulations made thereunder shall confer any right to land in any place as against the owner of the land or other persons interested therein.

*Small aircraft*

**92.** The provisions of this Order, other than Articles 45 and 65 thereof, shall not apply to or in relation to -

- (a) any balloon which at any stage of its flight is not more than 2 metres in any linear dimension including any basket or other equipment attached to the balloon;
- (b) any kite weighing not more than 2 kg.;
- (c) any other aircraft weighing not more than 5 kg. without its fuel.

SCHEDULE 1

PART A Articles 4(6), 23(1) and 90(7)

TABLE OF GENERAL CLASSIFICATION OF AIRCRAFT

Col. 1	Col. 2	Col. 3	Col. 4
--------	--------	--------	--------

┌

	┌	┌	Free balloon
		Non-mechanically	Captive Balloon
	Lighter than	driven	└
	air aircraft		
		Mechanically	Airship
		driven	┌
		Non-mechanically	Glider
		driven	Kite
Aircraft	Heavier than		└
	air aircraft		┌
			Aeroplane (Landplane)
			Aeroplane (Seaplane)
		Mechanically	Aeroplane (Amphibian)
		driven	Aeroplane (Self-launch-
		(flying machines)	ing Motor Glider)
			Gyroplane
	└	└	Helicopter
			└

PART B

Article 5(2)

NATIONALITY AND REGISTRATION MARKS OF AIRCRAFT

REGISTERED IN SEYCHELLES

**1.** The nationality mark of the aircraft shall be a group of two capital letters in Roman character and the registration mark shall be a group of three capital letters in Roman character assigned by the Minister on the registration of the aircraft. The letters

shall be without ornamentation and a hyphen shall be placed between the nationality mark and the registration mark.

2. The nationality and registration marks shall be painted on the aircraft or shall be affixed thereto by any other means ensuring a similar degree of permanence in the following manner :

(I) *Position of marks*

(a) *Flying machines and Gliders*

- (i) Wings: Except on aircraft having no fixed wing surface, the marks shall appear on the lower surface of the wing structure unless they extend across the whole surface of both wings. So far as possible the marks shall be located equidistant from the leading and trailing edges of the wings. The tops of the letters shall be towards the leading edge of the wing.
- (ii) Fuselage (or equivalent structure) or Vertical Tail Surface: The marks shall also be either on each side of the fuselage (or equivalent structure) between the wings and the tail surfaces, or on the upper halves of the vertical tail surfaces. When on a single vertical tail surface they shall be on both sides of the tail. When there is more than one vertical tail surface, the marks shall appear on the outboard sides of the outer tails.

(b) *Airships and Balloons*

- (i) Airships: The marks shall be on each side of the airship and also on the upper surface on the line of symmetry. They shall be placed length-wise near the maximum cross-section of the airship.
- (ii) Spherical Balloons: The marks shall be in two places diametrically opposite. They shall be placed near the maximum horizontal circumference of the balloon.
- (iii) Non-Spherical Balloons: The marks shall be on each side. They shall be placed near the maximum cross-section of the balloon immediately above either the rigging band or the points of attachment of the basket suspension cables.
- (iv) In the case of all airships and balloons the side marks shall be so placed as to be visible both from the sides and from the ground.

(II) *Size of Marks*

(a) *Flying Machines and Gliders*

- (i) Wings: The letters constituting each group of marks shall be of equal height. The height of the letters shall be at least 50 centimetres.
- (ii) Fuselage (or equivalent structure) or Vertical Tail Surfaces: The marks on the fuselage (or equivalent structure, shall not interfere with the visible outlines of the fuselage (or equivalent structure). The marks on the vertical tail surfaces shall be such as to leave a margin of at least 5 centimetres along each side of the vertical tail surface. The letters constituting each group of marks shall be of equal height. The height of the marks shall be at least 30 centimetres.

Provided that where owing to the structure of the aircraft a height of 30 centimetres is not reasonably practicable, the height shall be the greatest height reasonably practicable in the circumstances, but not less than 15 centimetres.

(b) *Airships and Balloons*

The letters constituting each group of marks shall be of equal height. The height of the letters shall be at least 75 centimetres.

(III) *Width and Spacing of Marks*

- (a) The width of each letter (except the letter I) and the length of the hyphen between the nationality mark and registration mark shall be two-thirds of the height of a letter.
- (b) The letters and hyphen shall be formed by solid lines and shall be of a colour clearly contrasting with the background on which they appear. The thickness of the lines shall be one-sixth of the height of a letter.
- (c) Each letter shall be separated from the letter which it immediately precedes or follows by a space equal to half the width of a letter. A hyphen shall be regarded as a letter for this purpose.

**3.** The nationality and registration marks shall be displayed to the best advantage, taking into consideration the constructional features of the aircraft and shall always be kept clean and visible.

**4.** In addition to the foregoing requirements of this Schedule the nationality and registration marks shall also be inscribed, together with the name and address of the registered owner of the aircraft, on a fireproof metal plate affixed in a prominent

position to the fuselage or car or basket, as the case may be, and near the main entrance to the aircraft.

PART C

Article 4(8)

AIRCRAFT DEALER'S CERTIFICATE - CONDITIONS

(1) The operator of the aircraft shall be the registered owner of the aircraft, who shall be the holder of an aircraft dealer's certificate granted under this Order.

(2) The aircraft shall fly only for the purpose of:

- (a) testing the aircraft; or
- (b) demonstrating the aircraft with a view to the sale of that aircraft or of other similar aircraft; or
- (c) proceeding to or from a place at which the aircraft is to be tested or demonstrated as aforesaid, or overhauled, repaired or modified; or
- (d) delivering the aircraft to a person who has agreed to buy, lease or sell it; or
- (e) proceeding to or from a place for the purpose of storage.

(3) Without prejudice to the provisions of Article 32 of this Order the operator of the aircraft shall satisfy himself before the aircraft takes off that the aircraft is in every way fit for the intended flight.

(4) The aircraft shall fly only within Seychelles.

## SCHEDULE 2

*Articles 3(1), 7(1) and 38(5)*

### A AND B CONDITIONS

The A Conditions and B Conditions referred to in Article 3(1), 7(1) and 38(5) of this Order are as follows:

#### *A Conditions*

- (1) The aircraft shall be either an aircraft in respect of which a certificate of airworthiness or validation has previously been in force under this Order, or an aircraft identical in design with an aircraft in respect of which such a certificate is or has been in force.
- (2) The aircraft shall fly only for the purpose of enabling it to:
  - (a) qualify for the issue or renewal of a certificate of airworthiness or of the validation thereof or the approval of a modification of the aircraft, after an application has been made for such issue, renewal, validation or approval as the case may be; or
  - (b) proceed to or from a place at which any inspection, approval, test or weighing of, or the installation of equipment in, the aircraft is to take place for a purpose referred to in subparagraph (a), after such an application has been made, or at which the installation of furnishings in, or the painting of, the aircraft is to be undertaken; or
  - (c) proceed to or from a place at which the aircraft is to be or has been stored.
- (3) The aircraft and its engines shall be certified as fit for flight by the holder of a licence as an aircraft maintenance engineer entitled in accordance with the provisions of Schedule 4 to this Order so to certify, or by a person approved by the Minister for the purpose of issuing certificates under this condition.
- (4) The aircraft shall carry the minimum flight crew specified in any certificate of airworthiness or validation which has previously been in force under this Order in respect of the aircraft, or is or has previously been in force in respect of any other aircraft of identical design.
- (5) The aircraft shall not carry any persons or cargo except persons performing duties in the aircraft in connection with the flight or persons who are carried in the aircraft to perform duties in connection with a purpose referred to in paragraph (2) of these Conditions.



- (6) The aircraft shall not fly over any congested area of a city, town or settlement except to the extent that it is necessary to do so in order to take off from or land at a Government aerodrome or a licensed aerodrome, in accordance with normal aviation practice.
- (7) Without prejudice to the provisions of Article 18(2) of this Order, the aircraft shall carry such flight crew as may be necessary to ensure the safety of the aircraft.

*B Conditions*

- (1) The flight shall be made under the supervision of a person approved by the Minister for the purposes of these Conditions, and subject to any additional conditions which may be specified in such approval.
- (2) If it is not registered in Seychelles or under the law of any country referred to in Article 3 of this Order, the aircraft shall be marked in a manner approved by the Minister for the purposes of these Conditions, and the provisions of Articles 14, 15, 19, 32, 35, 54 and 56 of this Order shall be complied with in relation to the aircraft as if it was registered in Seychelles so far as such provisions are applicable to the aircraft in the circumstances.
- (3) The aircraft shall fly only for the purpose of -
  - (a) experimenting with or testing the aircraft (including in particular its engines) and its equipment; or
  - (b) enabling it to qualify for the issue of a certificate of airworthiness or the validation thereof, or the approval of a modification of the aircraft; or
  - (c) proceeding to or from a place at which any experiment, inspection, approval, test or weighing of, or the installation of equipment in, the aircraft is to take place for a purpose referred to in subparagraph (a) or (b), or at which the installation of furnishings in, or the painting of, the aircraft is to be undertaken; or
  - (d) demonstrating the aircraft with a view to the sale of that aircraft or of other similar aircraft.
- (4) Without prejudice to the provisions of Article 18(2) of this Order, the aircraft shall carry such flight crew as may be necessary to ensure the safety of the aircraft.
- (5) The aircraft shall not carry any cargo, or any persons other than the flight crew except the following:

- (a) persons employed by the operator who carry out during the flight duties in connection with the purposes specified in paragraph (3) of these Conditions;
  - (b) persons employed by manufacturers of component parts of the aircraft (including its engines) who carry out during the flight duties in connection with the purposes so specified;
  - (c) persons approved by the Minister under Article 8(8) of this Order as qualified to furnish reports for the purposes of that Article;
  - (d) persons, other than those carried under the preceding provisions of this paragraph, who are carried in the aircraft in order to carry out a technical evaluation of the aircraft or its operation.
- (6) The aircraft shall not fly except in accordance with procedures which have been approved by the Minister in relation to that flight, over any congested area of a city, town or settlement.

### SCHEDULE 3

#### *Article 8*

#### **1. Categories of Aircraft**

Transport Category (Passenger).

General Purpose Category.

Transport Category (Cargo).

Aerial Work Category.

Private Category.

Special Category.

#### **2. The purposes for which the aircraft may fly are as follows :**

*Transport Category (Passenger):* Any purpose.

*General Purpose Category:* Any purpose.

*Transport Category (Cargo):* Any purpose, other than the public transport of passengers.

*Aerial Work Category:* Aerial work only.

*Private Category:* Any purpose other than public transport or aerial work.

*Special Category:* Any purpose, other than public transport, specified in the certificate of airworthiness but not including the carriage of passengers unless expressly permitted.

#### SCHEDULE 4

*Article 12*

#### MAINTENANCE ENGINEERS: PRIVILEGES OF LICENCES

An aircraft maintenance engineer may, subject to the conditions of his licence issue certificates as follows:

*Aircraft Maintenance Engineers - Category A (Aircraft)*

In relation to aircraft (not including engines) -

- (a) certificate of maintenance or certificates of release in accordance with the maintenance schedules approved under this Order;
- (b) certificates of compliance in respect of inspections, repairs, replacements and modifications so approved;
- (c) certificates of fitness of aircraft for flight under the "A Conditions".

*Aircraft Maintenance Engineers - Category B (Aircraft)*

In relation to aircraft (not including engines) -

Certificates of compliance in respect of inspections, overhauls, repairs, replacements and modifications approved under this Order.

*Aircraft Maintenance Engineers - Category C (Engines)*

In relation to engines -

- (a) certificates of maintenance or certificates of release in accordance with the maintenance schedules approved under this Order;
- (b) certificates of compliance in respect of inspections, repairs, replacements and modifications so approved;
- (c) certificates of fitness of aircraft engines for flight under the "A Conditions".

*Aircraft Maintenance Engineers - Category D (Engines)*

In relation to engines -

Certificates of compliance in respect of inspections, overhauls, repairs, replacements and modifications approved under this Order.

*Aircraft Maintenance Engineers - Category X*

Compasses.

Instruments.

Electrical Equipment.

Automatic Pilots.

In relation respectively to compasses, instruments, electrical equipment or automatic pilots -

- (a) certificates of maintenance or certificates of release in accordance with the maintenance schedules approved under this Order;
- (b) certificates of compliance in respect of inspections, repairs, replacements and modifications so approved.

*Aircraft Maintenance Engineers - Category R (Radio)*

In relation to aircraft radio stations -

- (a) certificate of maintenance or certificates of release in accordance with the maintenance schedules approved under this Order;
- (b) certificates of compliance in respect of inspection, repairs, replacements and modifications so approved.

The privileges of the licence shall also include the issue of certificates of compliance in respect of inspections, overhauls, repairs, replacements and modifications of any aircraft radio apparatus approved under this Order, if the licence bears an endorsement to that effect.

## SCHEDULE 5

*Articles 11(3) and 13(2)*

### AIRCRAFT EQUIPMENT

**1.** Every aircraft registered in Seychelles shall be provided, when flying in the circumstances specified in the first column of the Table set forth in paragraph 4 of this Schedule with adequate equipment, and for the purpose of this paragraph the expression

"adequate equipment" shall mean the scales of equipment respectively indicated in that Table:

Provided that, if the aircraft is flying in a combination of such circumstances the scales of equipment shall not on that account be required to be duplicated.

2. The equipment carried in an aircraft as being necessary for the airworthiness of the aircraft shall be taken into account in determining whether this Schedule is complied with in respect of that aircraft.

3. The following items of equipment shall not be required to be of a type approved by the Minister.

- (i) the equipment referred to in Scale A (ii).
- (ii) First Aid Equipment and Handbook, referred to in Scale B.
- (iii) Time-pieces, referred to in Scale F.
- (iv) Torches, referred to in Scales G, H and J.
- (v) Whistles, referred to in Scale H.
- (vi) Sea anchors, referred to in Scale I and J.
- (vii) Rocket signals, referred to in Scale I.
- (viii) Equipment for mooring, anchoring or manoeuvring aircraft on the water, referred to in Scale I.
- (ix) Paddles, referred to in Scale J.
- (x) Food and water, referred to in Scales J, U and V.
- (xi) First aid equipment, referred to in Scales J, U and V.
- (xii) Stoves, cooking utensils, snow shovels, ice saws, sleeping bags and Arctic suits, referred to in Scale V.

TABLE 1

Aircraft and Circumstances of Flight	Scale of Equipment Required													Extras									
	A	B	C	D	E	F	G	H	I	J	K	L	M		N	O	P	Q	R	S	T	U	V
(1) Flying machines flying for purposes other than public transport																							
(a) when flying at night.....	A			C	D																		
(b) When flying under Instrument Flight Rules																							
(i) outside controlled airspace	A			D																			
(ii) within controlled airspace	A			E	F																		
(c) when carrying out aerobatic manoeuvres.....	A												M										
(d) on all other flights.....	A																						
(2) Flying machines flying for the purpose of public transport.....																							
(a) when flying under Instrument Flight Rules																							
(i) in the case of flying machines of which the maximum total weight authorised exceeds 1,150kg.....	A	B			E	F																	
(ii) in the case of flying machines of which the maximum total weight authorised does not exceed 1,150kg.....	A	B																					
(b) outside controlled airspace.....	A	B		D																			
(i) outside controlled airspace.....	A	B																					
(ii) within controlled airspace.....	A	B		E	P																		

Airworthiness and Circumstances of Flight	Scale of Requirements Required																				Exams	
	A	B	C	D	E	F	G	H	I	J	K	L	M	N	O	P	Q	R	S	T		U
(b) when flying at night																						
(i) in the case of flying machines of which the maximum total weight authorized exceeds 1,150kg																						
(ii) in the case of flying machines of which the maximum total weight authorized does not exceed 1,150kg	A	B	C		E	F	G															
(c) when flying over water beyond gliding distance from land																						
(d) when flying over water																						
(i) in the case of an airplane																						
(ii) classified in its certificate of airworthiness as being of performance group A, C or X, or	A	B	C	D		F (R only)																
(iii) having as performance group classification in its certificate of airworthiness and of such a weight and performance that with any one of its power units incorporating and the remaining power unit or units operating within the maximum continuous power con-	A	B		D		F (R only)	H															

Aircraft and Circumstances of Flight	Scale of Equipment Required													Extras										
	A	B	C	D	E	F	G	H	I	J	K	L	M		N	O	P	Q	R	S	T	U	V	
<p>ditions specified in the certificate of airworthiness, performance schedule or flight manual relating to the aeroplane issued or rendered valid by the Minister, it is capable of a gradient of climb of at least 1 in 200 at an altitude of 5,000 feet in the International Standard Atmosphere specified in or ascertain able by reference to the certificate of airworthiness in force in respect of that aircraft.</p> <p>When either more than 420 nautical miles or more than 90 minutes flying time* from the nearest aerodrome at which an emergency landing can be made.....</p>	A	B		D		F (1) only	H		J															
(c) in the case of all other flying machines, when more than 30 minutes flying time* from such an aerodrome.....	A	B		D		F (1) only	H		J															
(e) on all flights which involve manœuvres on water.....	A	B		D		F (1) only	H		J															

\*For the purposes of this Table, flying time shall be calculated on the assumption that the aircraft is flying at the speed specified in the relevant certificate of Airworthiness at the speed for compliance with regulations governing flights over water.



Aircraft and Circumstances of Flight	Scale of Equipment Required													Extras									
	A	B	C	D	E	F	G	H	I	J	K	L	M		N	O	P	Q	R	S	T	U	V
(f) when flying at a height of 30,000 feet or more above mean level.....																							
(g) on flights when the weather reports or forecasts available at the aerodrome at the time of departure indicate that conditions favouring ice formation are likely to be met.....	A	B		D		F (i) only					K												
(h) when carrying out aerobatic manoeuvres.....	A	B		D		F (i) only						M											
(i) on all flights on which the aircraft carries a flight crew of more than one person.....													N										
(j) (i) on all flights by flying machines first registered (whether in Seychelles or elsewhere) on or after 1st January 1976 being turbine-jet aircraft with a maximum total weight authorised over 5,700 kg. or pressurised aircraft with a maximum total weight authorised over 11,400 kg.																							
(ii) on all flights by such flying machines as aforesaid, being aircraft first registered (whether in Seychelles or elsewhere) before 1st January 1967.																							
with the exception of any flight on which the expression of any flight on which the solar set specified in Scale O in paragraph																							

Aircraft and Circumstances of Flight	Scale of Equipments Required																				Extras		
	A	B	C	D	E	F	G	H	I	J	K	L	M	N	O	P	Q	R	S	T		U	V
able on take-off but the weather report or forecasts available to the commander of the aircraft at that time indicate that cumulo nimbus clouds or other potentially hazardous weather conditions which can be detected by the set when in working order are unlikely to be encountered on the intended route or any planned diversion therefrom, or the commander of the aircraft has satisfied himself that such weather conditions will be encountered in daylight and can be seen and avoided, and the aircraft is in either case operated throughout the flight in accordance with any relevant instructions given in the operations manual.....															O								
(k) on all flights for the purpose of the public transport of passengers.....																	Q						
(l) on all flights by a pressurised aircraft.....																			R				
(m) on all other flights.....	A	B																					
(n) when flying over substantially uninhabited land areas where, in the event of an emergency landing tropical conditions are likely to be met.....																							U

Aircraft and Circumstances of Flight	Scale of Equipment Required																	Extras							
	A	B	C	D	E	F	G	H	I	J	K	L	M	N	O	P	Q		R	S	T	U	V	W	
(e) when flying over substantially uninhabited land areas where, in the event of an emergency landing, polar conditions are likely to be met.....																							V		
(f) when flying at an altitude of more than 40,000 feet.....																								W	
(3) Gliders flying for purposes other than public transport or aerial work when flying by sight.....	A																								
(4) Gliders flying for the purposes of public transport or aerial work																									
(a) when outside controlled airspace under Instrument Flight Rules.....	A	B		D												F(0) only									
(b) when flying by night.....	A	B	C	D												F(0) only	G								
(c) when carrying out aerobatic manoeuvres.....	A	B		D												F(0) only								M	
(d) on all other flights.....	A	B		D												F(0) only									
(5) Turbine-engined aeroplanes over 5,700 kg. maximum total weight authorised and piston-engined aeroplanes over 27,000 kg. maximum total weight authorised																									
(a) which are operated by an air transport undertaking under a certificate of airworthiness of the Transport Category (Passenger) or the Transport Category (Cargo) or																									

Aircraft and Circumstances of Flight	Scale of Equipment Required																Extra							
	A	B	C	D	E	F	G	H	I	J	K	L	M	N	O	P		Q	R	S	T	U	V	W
<p>(b) in respect of which application has been made and not withdrawn or refused for such a certificate, and which fly under the "A" Conditions or under a certificate of airworthiness of the Special Category</p> <p>when flying on any flight</p> <p>Provided that this paragraph shall not Apply to:</p> <p>(i) aeroplanes over 230,000 kg. maximum total weight authorized which conform to a type which was first issued with a type certificate in Seychelles after 1st January 1970; or</p> <p>(ii) aeroplanes of 5,700 kg. or over but not over 230,000 kg. maximum total weight authorized which conform to a type which conforms to a type which was first issued with a type certificate (whether in Seychelles or elsewhere) after 1st April 1971.</p> <p>(6) On all flights by aeroplanes:</p> <p>(i) which conform to a type first issued with a type certificate (whether in Seychelles or elsewhere) on or</p>																								

Aircraft and Circumstances of Flight	Scale of Equipment Required													Extras										
	A	B	C	D	E	F	G	H	I	J	K	L	M		N	O	P	Q	R	S	T	U	V	W
<p>after 1st April 1971 and which are of 5,700 kg maximum total weight authorised or over and in respect of which there is in force a certificate of airworthiness in the Transport Category (Passengers) or Transport Category (Cargo); or</p> <p>(ii) which conform to a type certificate issued with a type certificate in Seychelles on or after 1st January 1970 and which are over 230,000 kg maximum total weight authorised and in respect of which there is in force such a certificate of airworthiness; or</p> <p>(iii) of 5,700 kg maximum total weight authorised or over which conform to a type certificate issued with a type certificate on or after 1st April 1971 (or 1st January 1970 in the case of an aeroplane over 230,000 kg maximum total weight authorised) in respect of which application has been made, and not withdrawn or refused, for such a certificate of airworthiness and which fly under the "A" Conditions or in respect of which there is in force a certificate of airworthiness in the Special</p>																								

Aircraft and Circumstances of Flight	Scale of Equipment Required													Extras										
	A	B	C	D	E	F	G	H	I	J	K	L	M		N	O	P	Q	R	S	T	U	V	W
(7) On all flights by aeroplanes:																								
(i) which conform to a type first issued with a type certificate (whether in Seychelles or elsewhere) on or after 1st April 1971 and which are 27,000 kg. maximum total weight authorised or over and in respect of which there is in force a certificate of airworthiness in the Transport Category (passenger) or the Transport Category (Cargo);																								
(ii) which conform to a type first issued with a type certificate in the Territory on or after 1st January 1970 and which are over 250,000 kg. maximum total weight authorised and in respect of which there is in force such a certificate of airworthiness; or																								
(iii) of 27,000 kg. maximum total weight authorised or over which conform to a type first issued with a type certificate on or after 1st April 1971 (or 1st January 1970 in the case of an aeroplane over 230,000 kg. maximum total weight authorised) in respect of which an application has																								

Aircraft and Circumstances of Flight	Scale of Equipment Required																				Extras					
	A	B	C	D	E	F	G	H	I	J	K	L	M	N	O	P	Q	R	S	T		U	V	W		
	<p>been made, and not withdrawn or refused, for such a certificate of airworthiness and which fly under the "A" Conditions or in respect of which there is in force a certificate of airworthiness in the Special Category</p>																									

5. The scales of equipment indicated in the foregoing Table shall be as follows:

*Scale A*

- (i) Spare fuses for all electrical circuits the fuses of which can be replaced in flight, consisting of 10 per cent, of the number of each rating or three of each rating, whichever is the greater;
- (ii) Maps, charts, codes and other documents and navigational equipment necessary, in addition to any other equipment required under this Order, for the intended flight of the aircraft, including any diversion which may reasonably be expected.
- (iii) Subject to Scale B(iii), a safety belt or safety harness for every seat in use.

*Scale B*

- (i) First-aid equipment of good quality, sufficient in quantity, having regard to the number of persons on board the aircraft, and including the following:
  - Roller bandages, triangular bandages, adhesive plaster, absorbent gauze, cotton wool (or wound dressings in place of the absorbent gauze and cotton wool), burn dressings, safety pins;
  - Haemostatic bandages or tourniquets, scissors;
  - Antesepic, analgesic and stimulant drugs;
  - Splints, in the case of aeroplanes the maximum total weight authorised of which exceeds 5,700 kg.
  - Handbook on First Aid.
- (ii) In the case of a flying machine used for the public transport of passengers in which, while the flying machine is at rest on the ground, the sill of any external door intended for the disembarkation of passengers, whether normally or in an emergency.
  - (a) is more than 1.82 metres from the ground when the undercarriage of the machine is in the normal position for taxiing, or
  - (b) would be more than 1.82 metres from the ground if the undercarriage or any part thereof should collapse, break or fail to function,



apparatus readily available for use at each such door consisting of a device or devices which will enable passengers to reach the ground safely in an emergency while the flying machine is on the ground, and can be readily fixed in position for use.

- (iii) If the maximum total weight authorised of the aircraft is more than 2,730 kg, a safety harness for every pilot's seat in use, in place of the safety belt referred to under Scale A:

Provided that the Minister may permit a safety belt to be fitted if it is satisfied that it is not reasonably practicable to fit a safety harness.

- (iv) If the commander cannot, from his own seat, see all the passengers' seats in the aircraft, a means of indicating to the passengers that seat belts should be fastened.

*Scale C*

- (i) Equipment for displaying the lights required by the Rules of the Air and Air Traffic Control;
- (ii) Electrical equipment, supplied from the main source of supply in the aircraft, to provide sufficient illumination to enable the flight crew properly to carry out their duties during flight;
- (iii) Unless the aircraft is equipped with radio, devices for making the visual signal specified in the Rules of the Air and Air Traffic Control as indicating a request for permission to land.

*Scale D*

- (i) Either (a) a turn indicator and a slip indicator; or  
(b) a gyroscopic bank and pitch indicator and a gyroscopic direction indicator;
- (ii) A sensitive pressure altimeter adjustable for changes in barometric pressure.

*Scale E*

- (i) A turn indicator and a slip indicator;
- (ii) A gyroscopic bank and pitch indicator;
- (iii) A gyroscopic direction indicator;
- (iv) A sensitive pressure altimeter adjustable for changes in barometric pressure;

Provided that any aircraft may, at the option of the operator, be equipped with an additional gyroscopic bank and pitch indicator in lieu of the turn indicator referred to in (i) of this Scale.

*Scale F*

- (i) A timepiece with a sweep second hand;
- (ii) A means of indicating whether the power supply to the gyroscopic instruments is adequate;
- (iii) A rate of climb and descent indicator;
- (iv) If the maximum total weight authorised of the aircraft is more than 5,700 kg. a means of indicating the outside air temperature;
- (v) If the maximum total weight authorised of the aircraft is more than 5,700 kg. two air speed indicators.

*Scale G*

- (i) Landing lights consisting of two single filament lamps, or one dual filament lamp with separately energised filaments;
- (ii) An electric lighting system to provide illumination in every passenger compartment;
- (iii) (a) If the aircraft, in accordance with its certificate of airworthiness, may carry more than nineteen persons over three years of age: two electric torches and an emergency lighting system to provide illumination in the passenger compartments sufficient to facilitate the evacuation of the aircraft notwithstanding the failure of the lighting systems specified in sub-paragraph (ii);  
(b) In the case of any other aircraft, one electric torch for each member of the crew of the aircraft;
- (iv) In the case of an aircraft of which the maximum total weight authorised exceeds 5,700 kg., means of observing the existence and build up of ice on the aircraft.

*Scale H*

For each person on board, a life-jacket equipped with a whistle and waterproof torch:

Provided that lifejackets constructed and carried solely for use by children under three years of age need not be equipped with a whistle.

*Scale I*

- (i) Additional flotation equipment, capable of supporting one-fifth of the number of persons on board, and provided in a place of stowage accessible from outside the flying machine;
- (ii) Parachute distress rocket signals capable of making, from the surface of the water, the pyrotechnical signal of distress specified in the Rules of the Air and Air Traffic Control and complying with Part III of Schedule 14 to the Merchant Shipping (Life-Saving Appliances) Rules 1965(a);
- (iii) A sea anchor and other equipment necessary to facilitate mooring, anchoring or manoeuvring the flying machine on water, appropriate to its size, weight and handling characteristics.

*Scale J*

- (i) Lifeafts sufficient to accommodate all persons on board the flying machine with the following equipment:
  - (a) means for maintaining buoyancy;
  - (b) a sea anchor;
  - (c) life lines, and means of attaching one life-raft to another;
  - (d) paddles or other means of propulsion;
  - (e) means of protecting the occupants from the elements;
  - (f) a waterproof torch;
  - (g) marine type pyrotechnical distress signals;
  - (h) means of making sea water drinkable, unless the full quantity of fresh water is carried as specified in sub-paragraph (i);
  - (i) for each 4 or proportion of 4 persons the life-raft is designed to carry:
    - 100 grammes of glucose toffee tablets;
    - ½ litre of fresh water in durable containers;

Provided that in any case in which it is not reasonably practicable to carry the quantity of water above specified, as large a quantity of fresh water as is reasonably practicable in the circumstances may be substituted. In no case however shall the quantity of water carried be less than is sufficient, when added to the amount of fresh water capable of being produced by means of the equipment specified in sub-paragraph

(h), to provide ½ litre of water for each 4 or proportion of 4 persons the life-raft is designed to carry.

(j) first aid equipment.

Items (f) to (j) inclusive, shall be contained in a pack.

(ii) The number of survival beacon radio apparatus carried when the aircraft is carrying the number of life-raft specified in column 1 of the following Table shall be not less than the number specified in, or calculated in accordance with, column 2:

TABLE

Column 1	Column 2
Not more than 8 life-rafts	2 survival beacon radio apparatus.
For every additional 4 or proportions of 4 life-rafts	1 additional survival beacon radio apparatus.

*Scale K*

PART I

(i) In every flying machine which is provided with means for maintaining a pressure greater than 700 millibars throughout the flight in the flight crew compartment and in the compartments in which passengers are carried-

(a) a supply of oxygen sufficient, in the event of failure to maintain such pressure, occurring in the circumstances specified in columns 1 and 2 of the Table set out in Part II of this Scale, for continuous use, during the periods specified in column 3 of the said Table, by the persons for whom oxygen is to be provided in accordance with column 4 of that Table, and

(b) in addition, in every case where the flying machine flies above flight level 350, a supply of oxygen in a portable container sufficient for the simultaneous first aid treatment of two passengers,

together with suitable and sufficient apparatus to enable such persons to use the oxygen.

(ii) In any other flying machine -

- (a) a supply of oxygen sufficient for continuous use by all the crew, and, if passengers are carried, by 10 per cent, of the number of passengers, for any period exceeding 30 minutes during which the flying machine flies above flight level 100 but not above flight level 130; and
- (b) a supply of oxygen sufficient for continuous use by all persons on board for the whole time during which the flying machine flies above flight level 130,

together with suitable and sufficient apparatus to enable such person to use the oxygen.

- (iii) The quantity of oxygen required for the purpose of complying with paragraphs (i) and (ii) of this Part of this Scale shall be computed in accordance with the information and instructions relating thereto specified in the operations manual relating to the aircraft pursuant to Item (vi) of Part A of Schedule 11 to this Order.

PART II

Column 1	Column 2	Column 3	Column 4
Vertical displacement of the flying machines in relation to flight levels	Capability of flying machine to descend (where relevant)	Period of supply of oxygen	Persons for whom oxygen is to be provided
Above flight level 1000	—	30 minutes of the period specified at A hereunder whichever is the greater	In addition to any passengers for whom oxygen is provided as specified below, all the crew
Above flight level 100 but not above flight level 300	Flying machine is either flying at or below flight level 150 or is capable of descending and continuing to destination as specified at X hereunder	30 minutes of the period specified at A hereunder whichever is the greater	10 per cent of number of passengers
	Flying machine is flying above flight level 150 and is not so capable	10 minutes or the period specified at B hereunder whichever is the greater and in addition	All passengers
		30 minutes of the period specified at A hereunder whichever is the greater	10 per cent of number of passengers
Above flight level 300 but not above flight level 350	Flying machine is capable of descending and continuing to destination as specified at Y hereunder	30 minutes of the period specified at A hereunder whichever is the greater	15 per cent of number of passengers

Column 1	Column 2	Column 3	Column 4
	Flying machine is not so capable	10 minutes or the period specified at B hereunder whichever is the greater and in addition	All passengers
Above flights level 350	—	30 minutes or the period specified at C hereunder whichever is the greater	15 per cent of number of passengers
		10 minutes or the period specified at B hereunder whichever is the greater and in addition	All passengers
		30 minutes or the period specified at C hereunder whichever is the greater	15 per cent of number of passengers

A. The whole period during which, after a failure to maintain a pressure greater than 700 millibars in the control compartment and in the compartments in which passengers are carried has occurred, the flying machine flies above flight level 100.

B. The whole period which, after failure to maintain such pressure has occurred, the flying machine flies above flight level 150.

C. The whole period during which, after a failure to maintain such pressure has occurred, the flying machine flies above flight level 100, but not above flight level 150.

X. The flying machine is capable, at the time when a failure to maintain such pressure occurs, of descending in accordance with the emergency descent procedure specified in the relevant flight manual and without flying below the minimum altitudes for safe flight specified in the operations manual relating to the aircraft, to flight level 150 within 6 minutes, and of continuing at or below that flight level 150 within 6 minutes, and of continuing at or below that flight level to its place of intended destination or any other place at which a safe landing can be made.

Y. The flying machine is capable, at the time when a failure to maintain such pressure occurs, of descending in accordance with the emergency descent procedure specified in the relevant flight manual and without flying below the minimum altitudes for safe flight specified in the operations manual relating to the aircraft, to flight level 150 within 4 minutes and of continuing at or below that flight level 150 within 6 minutes, and of continuing at or below that flight level to its place of intended destination or any other place at which a safe landing can be made.

*Scale L*

Equipment to prevent the impairment through ice formation of the functioning of the controls, means of propulsion, lifting surfaces, windows or equipment of the aircraft so as to endanger the safety of the aircraft.

*Scale M*

Safety harness for every seat in use.

*Scale N*

An intercommunication system for use by all members of the flight crew and including microphones, not of a hand-held type, for use by the pilot and flight engineer (if any).

*Scale O*

A radar set capable of giving warning to the pilot in command of the aircraft and to the co-pilot of the presence of cumulo-nimbus clouds and other potentially hazardous weather conditions: provided that if the set becomes unserviceable so as to give the warning only to one pilot, it shall nevertheless be sufficient so long as the aircraft is flying only to the place at which it first becomes reasonably practicable for the set to be repaired.

*Scale P*

A flight data recorder which is capable of recording, by reference to a time-scale, the following data -

- (a) indicated air speed;
- (b) indicated altitude;
- (c) vertical acceleration;
- (d) magnetic heading;
- (e) pitch attitude, if the equipment provided in the aeroplane is of such a nature as to enable this item to be recorded;
- (f) engine power, if the equipment provided in the aeroplane is of such a nature as to enable this item to be recorded;
- (g) flap position;
- (h) roll attitude, if the equipment provided in the aeroplane is of such a nature as to enable this item to be recorded:



Provided that any aeroplane having a maximum total weight authorised of less than 11,400 kg. may be provided with:

- (a) a flight data recorder capable of recording the data prescribed in sub-paragraphs (a) to (h) of this Scale; or
- (b) a 4 channel cockpit voice recorder.

In addition, on all flights by turbine-powered aeroplanes having a maximum total weight authorised of 27,000 kg. or over, a four channel cockpit voice recorder.

The recorder shall be so constructed that the record would be likely to be preserved in the event of an accident to the aeroplane.

#### *Scale Q*

If the maximum total weight authorised of the flying machine exceeds 5,700 kg. and it was first registered, whether in Seychelles or elsewhere, on or after 1st June 1965, a door between the flight crew compartment and any adjacent compartment to which passengers have access, which door shall be fitted with a lock or bolt capable of being worked from the flight crew compartment.

#### *Scale R*

- (i) Equipment sufficient to protect the eyes, nose and mouth of the pilot in command of the aircraft from the effects of smoke and noxious gases for a period of not less than 15 minutes; and
- (ii) Portable equipment sufficient to protect the eyes, nose and mouth of one other member of the crew of the aircraft from the effects of smoke and noxious gases for a period of not less than 8 minutes; and
- (iii) Equipment sufficient to protect from the effects of smoke and noxious gases the eyes of all members of the flight crew of the aircraft whose eyes are not adequately protected by other equipment.

#### *Scale S*

A flight recording system comprising:

- (i) in respect of aeroplanes of less than 11,400 kg. maximum total weight authorised either a 4 channel cockpit voice recorder or a flight data recorder capable of recording by reference to a time scale date from which the following information can be ascertained: the flight path of the aeroplane; the attitude of the aeroplane, and the basic lift, thrust and drag forces acting upon the aeroplane;

- (ii) in respect of aeroplanes of 11,400 kg. or over but less than 27,000 kg. maximum total weight authorised a 4 channel cockpit voice recorder and a flight data recorder capable of recording by reference to a time scale date from which the information specified in paragraph (i) can be ascertained;
- (iii) in respect of aeroplanes of 27,000 kg. maximum total weight authorised or over a 4 channel cockpit voice recorder and a flight data recorder capable of recording by reference to a time scale data from which the following information can be established: the flight part of the aeroplane; the attitude of the aeroplane; the basic lift, thrust and drag forces acting upon the aeroplane; the selection of height lift devices (if any) and airbrakes (if any); the position of primary flying control and pitch trim surfaces; cockpit warnings relating to engine fire and engine shut-down, cabin pressurisation, presence of smoke and hydraulic/pneumatic power supply; outside air temperature; instrument landing system deviations; use made of automatic flight control system; radio altitude (if any); and the level of essential AC electricity supply.

The cockpit voice recorder or flight data recorder, as the case may be, shall be so constructed that the record would be likely to be preserved in the event of an accident.

*Scale T*

An underwater sonar location device.

*Scale U*

- (a) 1 survival beacon radio apparatus;
- (b) marine type pyrotechnical distress signals;
- (c) for each 4 or proportion of 4 persons on board, 100 grammes of glucose coffee tablets;
- (d) for each 4 or proportion of 4 persons on board, ½ litre of fresh water in durable containers;
- (e) first aid equipment.

*Scale V*

- (a) 1 survival beacon radio apparatus;
- (b) marine type pyrotechnical distress signals;
- (c) for each 4 or proportion of 4 persons on board, 100 grammes of glucose coffee tablets;

- (d) for each 4 or proportion of 4 persons on board, ½ litre of fresh water in durable containers;
- (e) first aid equipment.
- (f) for every 75 or portion of 75 persons on board, 1 stove suitable for use with aircraft fuel;
- (g) 1 cooking utensil, in which snow or ice can be melted;
- (h) 2 snow shovels;
- (i) 2 ice saws;
- (j) single or multiple sleeping-bags, sufficient for the use of one-third of all persons on board;
- (k) 1 Arctic suit for each member of the crew of the aircraft.

*Scale W*

Cosmic radiation detection equipment calibrated in millirems per hour and capable of indicating the action and alert levels of radiation dose rate:

Provided that an aircraft shall not be required to carry the said equipment if before take-off the equipment is found to be unserviceable and it is not reasonably practicable to repair or replace it at the aerodrome of departure and the radiation forecast available to the commander of the aircraft indicates that hazardous radiation conditions are unlikely to be encountered by the aircraft on its intended route or any planned diversion therefrom.

SCHEDULE 6

Article 14

RADIO EQUIPMENT TO BE CARRIED IN AIRCRAFT

**1.** Every aircraft shall be provided, when flying in the circumstances specified in the first column of the Table set forth in paragraph 2 of this Schedule, with the scales of equipment respectively indicated in that Table:

Provided that, if the aircraft is flying in a combination of such circumstances the scales of equipment shall not on that account be required to be duplicated.

2.

TABLE

Aircraft and Circumstances of Flight	Scale of Equipment Required						
	A	B	C	D	E	F	G
(1) All aircraft within Seychelles :							
(a) When flying under Instrument Flight Rules within controlled airspace .....	A	B				F	
(b) Where required by the Rules of the Air and Air Traffic Control to comply in whole or in part with the Instrument Flight Rules in Visual Meteorological Conditions .....	A*	B*				F*	
(c) when flying within any airspace in respect of which special rules are prescribed by the said Rules in relation to a particular aerodrome, so as to require two-way radio communication with that aerodrome .....	A*						
(d) when making an approach to landing at an aerodrome this sub-paragraph .....							G*
(2) All aircraft (other than gliders) within Seychelles when flying at or above flight level 245 or within such controlled airspace as may be notified for the purpose of this sub-paragraph .....	A*	B*			E*	F*	
(3) All aircraft registered in Seychelles wherever they may be:							
(a) when flying for the purpose of public transport under instrument Flight Rules:							
(i) while making an approach to landing .....	A	B	C	D			
(ii) on all other occasions .....	A	B	C				
(b) over 2,300 kg. maximum total weight authorised when flying for the purpose of public transport under Visual Flight Rules .....	A	B					
(c) not over 2,300 kg. maximum total weight authorised when flying for the purpose of public transport under Visual Flight							

Rules:							
(i) over a route on which navigation is not effected solely by visual reference to landmarks .....	A	B					
(ii) over water, beyond gliding distance from any land .....	A						

\*Unless the appropriate air traffic control unit otherwise permits in relation to the particular flight and provided that the aircraft complies with any instructions which the air traffic control unit may give in the particular case.

3. The scales of radio equipment indicated in the foregoing Table shall be as follows:

*Scale A*

Radio equipment capable of maintaining two-way communication with the appropriate aeronautical radio stations.

*Scale B*

Radio equipment capable of enabling the aircraft to be navigated on the intended route including the equipment specified in Regulation 11 in Schedule 15 to this Order.

*Scale C*

Radio equipment capable of receiving from the appropriate aeronautical radio stations meteorological broadcasts relevant to the intended flight.

*Scale D*

Radio equipment capable of receiving signals from one or more aeronautical radio stations on the surface to enable the aircraft to be guided to a point from which a visual landing can be made at the aerodrome at which the aircraft is to land.

*Scale E*

Such type of radio equipment as may be notified as being capable of (a) replying to an interrogation from secondary surveillance radar units on the surface and (b) being set in accordance with such instructions as may be given to the aircraft by the appropriate air traffic control unit.

*Scale F*

Radio equipment capable of providing a continuous indication of the aircraft's distance from the appropriate aeronautical radio stations.

*Scale G*

Radio equipment capable of enabling the aircraft to make an approach to landing using the Instrument Landing System.

**4.** All aircraft registered in Seychelles when flying to, from or over Berlin, Germany, shall be equipped with radio navigation equipment appropriate to the route, including automatic direction finding equipment and any one of the following:

- (i) equipment which will enable the aircraft to be navigated by means of signals received from radio navigation land stations forming part of the Decca radio navigation system, or
- (ii) equipment capable of giving visual indications of bearings of the aircraft by means of signals received from very high frequency omni-directional radio ranges.

In this sub-paragraph "automatic direction finding equipment" means radio navigation equipment which automatically indicates the bearing of any radio station transmitting the signals received by such equipment.

SCHEDULE 7

Article 15

AIRCRAFT, ENGINE AND PROPELLER LOG BOOKS

**1.** *Aircraft Log Book*

The following entries shall be included in the aircraft log book:

- (a) the name of the constructor, the type of the aircraft, the number assigned to it by the constructor and the date of the construction of the aircraft;
- (b) the nationality and registration marks of the aircraft;
- (c) the name and address of the operator of the aircraft;
- (d) the date of each flight and the duration of the period between take-off and landing, or, if more than one flight as made on that day, the number of flights and the total duration of the periods between take-offs and landings on that day;
- (e) particulars of all maintenance work carried out on the aircraft or its equipment;
- (f) particulars of any defects occurring in the aircraft or in any equipment required to be carried therein by or under this Order, and of the action

taken to rectify such defects including a reference to the relevant entries in the technical log required by Article 9(6) and (7) of this Order;

- (g) particulars of any overhauls, repairs, replacements and modifications relating to the aircraft or any such equipment as aforesaid:

Provided that entries shall not be required to be made under sub-paragraphs (e), (f) and (g) in respect of any engine or variable pitch propeller.

## **2. *Engine Log Book***

The following entries shall be included in the engine log book:

- (a) the name of the constructor, the type of the engine, the number assigned to it by the constructor and the date of the construction of the engine;
- (b) the nationality and registration marks of each aircraft in which the engine is fitted;
- (c) the name and address of the operator of each such aircraft;
- (d) the date of each flight and the duration of the period between take-off and landing, or, if more than one flight was made on that day, the number of flights and the total duration of the periods between take-offs and landings on that day;
- (e) particulars of all maintenance work done on the engine;
- (f) particulars of any defects occurring in the engine, and of the rectification of such defects, including a reference to the relevant entries in the technical log required by Article 9(6) and (7) of this Order;
- (g) particulars of all overhauls, repairs, replacements and modifications relating to the engine or any of its accessories.

## **3. *Variable Pitch Propeller Log Book***

The following entries shall be included in the variable pitch propeller log book:

- (a) the name of the constructor, the type of the propeller, the number assigned to it by the constructor and the date of the construction of the propeller;
- (b) the nationality and registration marks of each aircraft, and the type and number of each engine, to which the propeller is fitted;
- (c) the name and address of the operator of each such aircraft;
- (d) the date of each flight and the duration of the period between take-off and landing, or, if more than one flight was made on that day, the number of

flights and the total duration of the periods between take-offs and landings on that day;

- (e) particulars of all maintenance work done on the propeller;
- (f) particulars of any defects occurring in the propeller, and of the rectification of such defects, including a reference to the relevant entries in the technical log required by Article 9(6) and (7) of this Order;
- (g) particulars of any overhauls, repairs, replacements and modifications relating to the propeller.

## SCHEDULE 8

Article 18(4)

### AREAS SPECIFIED IN CONNECTION WITH THE CARRIAGE OF FLIGHT NAVIGATORS AS MEMBERS OF THE FLIGHT CREWS OR APPROVED NAVIGATIONAL EQUIPMENT ON PUBLIC TRANSPORT AIRCRAFT

The following areas are hereby specified for the purposes of Article 18(4) of this Order:

#### *Area A - Arctic*

All that area north of latitude 67°north, but excluding any part thereof lying within 300 nautical miles of Norway.

#### *Area B - Antarctic*

All that area south of latitude 55°south.

#### *Area C - Sahara*

All that area enclosed by rhumb lines joining successively the following points:

32°north latitude 03°west longitude

24 " " 14° " "

14°north latitude 14°west longitude

18° " " 28° east "

24° " " 28° " "



28°	"	"	23°	"	"
32°	"	"	03°west	"	"

*Area D - Arabian Desert*

All that area enclosed by rhumb lines joining successively the following points:

22°north latitude			42°east longitude		
16°	"	"	46°	"	"
20°	"	"	55°	"	"
24	"	"	48°	"	"
22	"	"	42°	"	"

*Area E - South America (Central)*

All that area enclosed by rhumb lines joining successively the following points:

04°north latitude			72°west longitude		
04°	"	"	60°	"	"
08°	"	"	42°	"	"
18°	"	"	54°	"	"
18°	"	"	60°	"	"
14°	"	"	72°	"	"
05°	"	"	76°	"	"
04°	north	"	72°	"	"

*Area F - Pacific Ocean*

All that area enclosed by rhumb lines joining successively the following points:

55°south latitude			75°west longitude		
20°	"	"	73°	"	"
05°	"	"	85°	"	"
05°	north	"	80°	"	"

15°	north latitude	105° west longitude
30°	" "	125° " "
55°	" "	140° " "
67°	" "	180° " "
60°	" "	180° " "
20°	" "	128° " "
20°	" "	128° east longitude
04°	north latitude	128° east longitude
00	" "	165° west longitude
55°	south "	180° " "
55°	" "	75° " "

*Area G - Australia*

All that area enclosed by rhumb lines joining successively the following points:

18°	south latitude	123°
30°	" "	118° " "
30°	" "	135° " "
18°	" "	123° " "

*Area H - Indian Ocean*

All that area enclosed by rhumb lines joining successively the following points:

35°	south latitude	110° east longitude
20°	" "	110° " "
13°	" "	120° " "
10°	" "	100° " "
13°	north "	91° " "
13°	" "	86° " "

00°	"	"	80°	"	"
20°	north	"	67°	"	"
20°	"	"	62°	"	"
05°	south	"	43°	"	"
20°	"	"	60°	"	"
25°	south	"	60°	"	"
40°	south latitude	10°	east longitude		
55°	"	"	10°	"	"
55°	"	"	180°	"	"
35°	"	"	110°	"	"

*Area I - North Atlantic Ocean*

All that area enclosed by rhumb lines joining successively the following points:

55°	north latitude	15°	west longitude		
67°	"	"	40°	"	"
67°	"	"	60°	"	"
45°	"	"	45°	"	"
40°	"	"	63°	"	"
40°	"	"	19°	"	"
55°	"	"	15°	"	"

*Area J - South Atlantic Ocean*

All that area enclosed by rhumb lines joining successively the following points:

40°	north latitude	63°	west longitude		
19°	"	"	63°	"	"
05°	south	"	30°	"	"
55°	"	"	55°	"	"

55°	"	"	10°	east	"
05°	"	"	10°	"	"
02°	north	"	05°	"	"
02°	"	"	10°	west	"
15°	"	"	25°	"	"
40°	"	"	19°	"	"
40°	"	"	63°	"	"

*Area K - Northern Canada*

All that area enclosed by rhumb lines joining successively the following points:

67°	north latitude	130°	west longitude		
55°	"	"	115°	"	"
55°	"	"	70°	"	"
67°	"	"	60°	"	"
67°	"	"	130°	"	"

SCHEDULE 9

Article 20

FLIGHT CREW OF AIRCRAFT: LICENCES AND RATINGS

PART A - LICENCES

*Minimum Age, Period of Validity, Privileges*

1. Aeroplane Pilots

Private Pilot's Licence (Aeroplanes)

Minimum Age - 17 years

No maximum period of validity.

*Privileges:* The holder of the licence shall be entitled to fly as pilot in command or co-pilot of an aeroplane of any of the types specified in the aircraft rating included in the licence;

Provided that:

- (a) he shall not fly such an aeroplane for the purpose of public transport or aerial work, other than aerial work which consists of the giving of instruction in flying in an aeroplane owned, or operated under arrangements entered into, by a flying club of which the person giving and the person receiving the instruction are both members;
- (b) he shall not receive any remuneration for his services as a pilot on a flight other than remuneration for the giving of such instruction as is specified in paragraph (a) of this proviso;
- (c) he shall not, unless his licence includes an instrument meteorological conditions rating (aeroplanes), fly as pilot in command of such an aeroplane -
  - (i) on a flight outside controlled airspace:
    - (aa) when the flight visibility is less than one nautical mile; or
    - (bb) when any passenger is carried and the aeroplane is flying either above 3,000 feet above mean sea level in Instrument Meteorological Conditions or at or below 3,000 feet above mean sea level in a flight visibility of less than 3 nautical miles; or
  - (ii) on a special VFR flight in a control zone in a flight visibility of less than 5 nautical miles, except on a route or in an aerodrome traffic zone notified for the purposes of this sub-paragraph;
- (d) he shall not fly as pilot in command of such an aeroplane at night on a flight on which any passenger is carried unless:
  - (i) his licence includes a night rating (aeroplanes); and
  - (ii) his licence includes an instrument rating (aeroplanes) or he has within the immediately preceding 6 months carried out as pilot in command not less than 5 take-offs and 5 landings at a time when the depression of the centre of the sun was not less than 12° below the horizon.

*Commercial Pilot's Licence (Aeroplanes)*

*Minimum Age - 18 years*

*Maximum Period of Validity - 10 years*

Privileges:

- (1) The holder of the licence shall be entitled to exercise the privileges of a Private Pilot's Licence (Aeroplanes) which includes an instrument

meteorological conditions rating (aeroplanes) and a night rating (aeroplanes) and shall be entitled to fly as pilot in command of an aeroplane on a special VFR flight notwithstanding that the flight visibility is less than 1½ nautical miles; and

- (2) he shall be entitled to fly as pilot in command of an aeroplane of a type specified in Part I of the aircraft rating included in the licence when the aeroplane is engaged on a flight for any purpose whatsoever:
  - (a) he shall not, unless his licence includes an instrument rating (aeroplanes), fly such an aeroplane on any scheduled journey;
  - (b) he shall not fly such an aeroplane at night on which any passenger is carried unless his licence includes an instrument rating (aeroplanes) or he has within the immediately preceding 90 days carried out as pilot in command not less than 5 take-offs and 5 landings at a time when the depression of the centre of the sun was not less than 12° below the horizon;
  - (c) he shall not, unless his licence includes an instrument rating (aeroplanes) fly any such aeroplane of which the maximum total weight authorised exceeds 2,300 kg. on any flight for the purpose of public transport, except a flight beginning and ending at the same aerodrome and not extending beyond 25 nautical miles from that aerodrome;
  - (d) he shall not fly such an aeroplane on a flight for the purpose of public transport if its maximum total weight authorised exceeds 5,700 kg; and
- (3) he shall be entitled to fly as co-pilot of any aeroplane of a type specified in the aircraft rating included in the licence when the aeroplane is engaged on a flight for any purpose whatsoever.

*Senior Commercial Pilot's Licence (Aeroplanes)*

*Maximum Age - 21 years*

*Maximum Period of Validity - 10 years*

*Privileges:* The holder of the licence shall be entitled to exercise the privileges of a Commercial Pilot's Licence (Aeroplanes) except that in proviso (d) to paragraph (2) of those privileges, 20,000 kg. shall be substituted for 5,700 kg.

*Airline Transport Pilot's Licence (Aeroplanes)*

*Minimum Age - 21 years*

*Maximum Period of Validity - 10 years*

*Privileges:* The holder of the licence shall be entitled to exercise the privileges of a Commercial Pilot's Licence (Aeroplanes) except that for proviso (d) to paragraph (2) of those privileges there shall be substituted:

- (d) he shall not at any time after he attains the age of 60 years fly such an aeroplane for the purpose of public transport if its maximum total weight authorised exceeds 20,000 kg.

## *2. Helicopter and Gyroplane Pilots*

*Private Pilot's Licence (Helicopters and Gyroplanes)*

*Minimum Age - 17 years*

*No maximum period of validity.*

*Privileges:* The holder of the licence shall be entitled to fly as pilot in command or co-pilot of a helicopter or gyroplane of any of the types specified in the aircraft rating included in the licence.

Provided that:

- (a) he shall not fly such a helicopter or gyroplane for the purpose of public transport or aerial work other than aerial work which consists of the giving of instruction in flying in a helicopter or gyroplane owned, or operated under arrangements entered into, by a flying club of which the person giving and the person receiving the instruction are both members;
- (b) he shall not receive any remuneration for his services on a flight other than remuneration for the giving of such instruction as is specified in paragraph (a) of this proviso;
- (c) he shall not fly as pilot in command of such a helicopter or gyroplane at night on a flight on which any passenger is carried unless his licence includes a night rating (helicopters and gyroplanes) and he has within the immediately preceding 90 days carried out as pilot in command not less than 5 flights, each consisting of a take-off, a transition from hover to forward flight, a climb to at least 500 feet, and a landing, at a time when the depression of the centre of the sun was not less than 12° below the horizon.

*Commercial Pilot's Licence (Helicopters and Gyroplanes)*

*Minimum Age - 18 years*

*Maximum Period of Validity - 10 years*

*Privilege:*

- (1) The holder of the licence shall be entitled to exercise the privileges of a Private Pilot's Licence (Helicopters and Gyroplanes) which includes a night rating (helicopters and gyroplanes); and
- (2) he shall be entitled to fly as pilot in command of any helicopter or gyroplane specified in Part 1 of the aircraft rating included in the licence when the helicopter or gyroplane is engaged on a flight for any purpose whatsoever:

Provided that:

- (a) he shall not fly such a helicopter or gyroplane at night on a flight on which any passenger is carried unless he has within the immediately preceding 90 days carried out as pilot in command not less than 5 flights, each consisting of a take-off, a transition from hover to forward flight, a climb to at least 500 feet, and a landing, at a time when the depression of the centre of the sun was not less than 12° below the horizon;
- (b) he shall not fly such a helicopter or gyroplane on a flight for the purpose of public transport if its maximum total weight authorised exceeds 5,700 kg.; and
- (3) he shall be entitled to fly as co-pilot of any helicopter or gyroplane specified in the aircraft rating included in the licence when the helicopter or gyroplane is engaged on a flight for any purpose whatsoever.

*Airline Transport Pilot's Licence (Helicopters and Gyroplanes)*

*Minimum Age - 21 years*

*Maximum Period of Validity - 10 years*

*Privileges:* The holder of the licence shall be entitled to exercise the privileges of Commercial Pilot's Licence (Helicopters and Gyroplanes) except that proviso (b) to paragraph (2) shall not apply.

*3. Balloon and Airship Pilots*

*Private Pilot's Licence (Balloons and Airships)*

*Minimum Age - 17 years*

*No Maximum period of validity.*

*Privileges:* The holder of the licence shall be entitled to fly as pilot in command of any type of balloon or airship specified in Part 1 of the aircraft rating included in the licence and co-pilot of any type of balloon or airship specified in such aircraft rating:



Provided that:

- (a) he shall not fly such balloon or airship for the purpose of public transport or aerial work, other than aerial work which consists of the giving of instruction in flying in a balloon or airship owned, or operated under arrangements entered into, by a flying club of which the person giving and the person receiving the instruction are both members;
- (b) he shall not receive any remuneration for his service as a pilot other than remuneration for the giving of such instruction as is specified in paragraph (a) of this proviso.

*Commercial Pilot's Licence (Balloons)*

*Minimum Age - 18 years*

*Maximum Period of Validity - 6 months\**

*Privileges:*

- (1) The holder of the licence shall be entitled to exercise the privileges of a Private Pilot's Licence (Balloons and Airships); and
- (2) he shall be entitled to fly, when the balloon is flying for any purpose whatsoever, as pilot in command or co-pilot of any type of balloon specified in the aircraft rating included in the licence.

*Commercial Pilot's Licence (Airships)*

*Minimum Age - 18 years*

*Maximum Period of validity - 6 years\**

*Privileges :*

- (1) The holder of the licence shall be entitled to exercise the privileges of a Private Pilot's Licence (Ballons and Airships); and
- (2) he shall be entitled to fly, when the airship is flying for any purpose whatsoever, as pilot in command of any type of airship specified in Part 1 of the aircraft rating included in the licence and as co-pilot of any type of airship specified in such aircraft rating.

*4. Glider Pilots*

*Commercial Pilot's Licence (Glider)*

*Minimum Age - 18 years*

*Maximum Period of Validity - 6 months*

*Privileges:* The holder of the licence shall be entitled to fly for any purpose as pilot in command or co-pilot of -

- (a) any glider of which the maximum total weight authorised does not exceed 680 kg.;
- (b) any glider of which the maximum total weight authorised exceeds 680 kg. and which is of a type specified in the rating included in the licence.

*Other Flight Crew*

*Flight Navigator's Licence*

*Minimum Age - 21 years*

*Maximum Period of Validity - 10 years*

*Privileges:* The holder of the licence shall be entitled to act as flight navigator in any aircraft.

*Flight Engineer's Licence*

*Minimum Age - 21 years*

*Maximum Period of Validity - 10 years*

*Privileges:* The holder of the licence shall be entitled to act as flight engineer in any type of aircraft specified in the aircraft rating included in the licence.

*Flight Radiotelephony Operator's General Licence*

*Minimum Age - 18 years*

*Maximum Period of Validity - 10 years*

*Privileges:* The holder of the licence shall be entitled to operate radiotelephony apparatus in any aircraft.

*Flight Radiotelephony Operator's Restricted Licence*

*Minimum Age - 17 years*

*Maximum Period of Validity - 10 years*

*Privileges:* The holder of the licence shall be entitled to operate radiotelephony apparatus in any aircraft if the stability of the frequency radiated by the transmitter is

maintained automatically but shall not be entitled to operate the transmitter, or to adjust its frequency, except by the use of external switching devices.

*Flight Radiotelegraphy Operator's Licence*

*Minimum Age - 20 years*

*Maximum Period of Validity - 12 months*

*Privileges:* The holder of the licence shall be entitled to operate radiotelegraphy and radiotelephony apparatus in any aircraft.

*Flight Radiotelegraphy Operator's Temporary Licence*

*Minimum Age - 18 years*

*Maximum Period of Validity - 12 months*

*Privileges:* The holder of the licence shall be entitled to operate radiotelegraphy and radiotelephony apparatus in any aircraft under the supervision of a person who is the holder of a flight radiotelegraphy operator's licence.

## PART B - RATINGS

1. The following ratings may be included in a pilot's licence (other than a student pilot's licence) granted under Part IV of this Order, and, subject to the provisions of this Order and of the licence, the inclusion of a rating in a licence shall have the consequences respectively specified as follows:

*Aircraft Rating.* The licence shall entitle the holder to act as pilot only of aircraft of the types specified in the aircraft rating and different types of aircraft may be specified in respect of different privileges of a licence.

*Instrument Meteorological Conditions Rating (Aeroplanes)* shall entitle the holder of a private pilot's licence (aeroplanes) to fly as pilot in command of an aeroplane:

- (a) on a flight outside controlled airspace without being subject to the restrictions contained in proviso (c) (i) to the privileges of such a licence set out in Part A of this Schedule; and
- (b) on a special VFR flight in a control zone in a flight visibility of less than 5, but not less than 1½, nautical miles.

*Instrument Rating (Aeroplanes)* shall entitle the holder of the licence to act as pilot in command or co-pilot of an

aeroplane flying in controlled airspace in circumstances which require compliance with the Instrument Flight Rules.

*Night Rating (Aeroplanes)* shall entitle the holder of a private pilot's licence (aeroplanes) to act as pilot in command at night of an aeroplane in which a passenger is carried.

*Night Rating (Helicopters and Gyroplanes)* shall entitle the holder of a private pilot's licence (helicopters and gyroplanes) to act as pilot in command at night of a helicopter or gyroplane in which a passenger is carried.

*Towing Rating (Flying Machines)* shall entitle the holder of the licence to act as pilot of a flying machine while towing a glider in flight for the purpose of public transport or aerial work.

*Flying Instructor's Rating* shall entitle the holder of the licence to give instruction in flying aircraft of such types as may be specified in the rating for that purpose.

*Assistant Flying Instructor's Rating* shall entitle the holder of the licence to give instruction in flying aircraft of such types as may be specified in the rating for that purpose:

Provided that -

- (a) such instruction shall only be given under the supervision of a person present during the take-off and landing at the aerodrome at which the instruction is to begin and end and holding a pilot's licence endorsed with a flying instructor's rating; and
  - (b) an assistant flying instructor's rating shall not entitle the holder of the licence to give directions to the person undergoing instruction in respect of the performance by that person of -
    - (i) his first solo flight; or
    - (ii) his first solo flight by night; or
    - (iii) his first solo cross-country flight otherwise than by night; or
    - (iv) his first solo cross-country flight by night.
2. An aircraft rating included in a flight engineer's licence shall entitle the holder of the licence to act as flight engineer only of aircraft of a type specified in the aircraft rating.
3. For the purposes of this Schedule:

"Solo flight" means a flight on which the pilot of the aircraft is not accompanied by a person holding a pilot's licence granted or rendered valid under this Order.

"Cross-country flight" means any flight during the course of which the aircraft is more than 3 nautical miles from the aerodrome of departure.

**PART C - CERTIFICATE OF TEST OR EXPERIENCE**

- 1.** (a) A certificate of test or a certificate of experience required by Article 20(4) of this Order shall not be appropriate to the functions to be performed on a flight unless it is a certificate appropriate to the description of the flight according to the following Table :-

CASE	CLASS OF LICENCE	DESCRIPTION OF FLIGHT	CERTIFICATE REQUIRED
A	Private Pilot's Licence (Aeroplanes) Private Pilot's Licence (Helicopters and Gyroplanes)	Any flight within the privileges of the licence.	Certificate of test or certificate of experience
B	Commercial Pilot's Licence (Aeroplanes) Commercial Pilot's Licence (Helicopters and Gyroplanes) Commercial Pilot's Licence (Gliders) Senior Commercial Pilot's Licence (Aeroplanes) Airline Transport Pilot's Licence (Aeroplanes) Airline Transport Pilot's Licence (Helicopters and Gyroplanes)	Carriage of passengers on a flight in respect of which the holder of the licence receives remuneration	Certificate of test
C	Commercial Pilot's Licence (Aeroplanes) Commercial Pilot's Licence (Helicopters and Gyroplanes) Commercial Pilot's Licence (Gliders) Senior Commercial Pilot's Licence (Aeroplanes) Airline Transport Pilot's Licence (Aeroplanes) Airline Transport Pilot's Licence (Helicopters and Gyroplanes)	For public transport	Certificate of test
D	Commercial Pilot's Licence (Aeroplanes) Commercial Pilot's Licence (Helicopters and Gyroplanes) Commercial Pilot's Licence (Gliders) Senior Commercial Pilot's Licence (Aeroplanes) Airline Transport Pilot's Licence (Helicopters and Gyroplanes)	For aerial work	Certificate of test or certificate of experience

CASE	CLASS OF LICENCE	DESCRIPTION OF FLIGHT	CERTIFICATE REQUIRED
E	Commercial Pilot's Licence (Aeroplanes) Commercial Pilot's Licence (Helicopters and Gyroplanes) Commercial Pilot's Licence (Gliders) Senior Commercial Pilot's Licence (Aeroplanes) Airline Transport Pilot's Licence (Aeroplanes) Airline Transport Pilot's Licence (Helicopters and Gyroplanes)	Flight for any purpose other than Cases B, C or D	Certificate of test or certificate of experience
F	Flight Navigator's Licence	Flights to which Article 18(4) of this Order applies	Certificate of experience
G	Flight Engineer's Licence	For public transport	Certificate of test
H	Flight Engineer's Licence	Any flight other than for public transport	Certificate of test or certificate of experience

- (b) For the purposes of this Part of this Schedule references to Cases are references to the Cases indicated in the first Column of the Table in Paragraph 1(a) of this Part of this Schedule.

*Certificate of test*

**2.** A certificate of test required by Article 20(4) or 20(5) of this Order shall be signed by a person authorised by the Minister to sign certificates of this kind and shall certify the following particulars:

- (a) the functions to which the certificate relates;
- (b) that the person signing the certificate is satisfied that on a date specified in the certificate the holder of the licence or personal flying logbook of which the certificate forms part, as the case may be, passed an appropriate test of his ability to perform the functions to which the certificate relates;
- (c) the type of aircraft or flight simulator in or by means of which the test was conducted;
- (d) the date on which it was signed.

*Nature of test*

**3.** The appropriate test referred to in paragraph 2 of this Part of this Schedule shall be:

- (a) in the case of a test which entitles the holder of the licence of which the certificate forms part to act as pilot in command and/or co-pilot of aircraft of the type specified in the certificate, a test of the pilot's competence to fly the aircraft as pilot in command and/or co-pilot and shall where the Minister so specifies in respect of the whole or part of a test be conducted in an aircraft in flight or by means of a flight simulator approved by the Minister under Article 20(10) of this Order;
- (b) in the case of a test which entitles the holder of the licence of which the certificate forms part to act as flight engineer of aircraft of the type specified in the certificate, a test of the flight engineer's competence to perform the duties of a flight engineer in the type of aircraft to be used on the flight and shall, where the Minister so specifies in respect of the whole or part of a test, be conducted in an aircraft in flight or by means of a flight simulator approved by the Minister under Article 20(10) of this Order;
- (c) in the case of a test which entitles the holder of the licence of which the certificate forms part to perform the functions to which an Instrument Rating relates, a test of his ability to perform the functions to which the rating relates and shall, where the Minister so specifies in respect of the



whole or part of the test, be conducted in an aircraft in flight or by means of a flight simulator approved by the Minister under Article 20(10) of this Order;

- (d) in the case of a test which entitles the holder of the licence of which the certificate forms part to perform the functions to which a flying instructor's rating, an assistant flying instructor's rating or an instrument meteorological conditions rating relates, a test of his ability to perform the functions to which the rating relates and shall be conducted in an aircraft in flight.

#### *Period of Validity of Certificate of Test*

**4** (a) A certificate of test required by Article 20(4) of this Order shall not be valid in relation to a flight made more than 13 months in Cases A, B, E and H, or more than 6 months in Cases C, D and G, after the date of the test which it certifies:

Provided that in the case of Cases C, D and G two certificates of test shall together be deemed to constitute a valid certificate of test if they certify flying tests conducted on two occasions within the period of 13 months preceding the flight on which the functions are to be performed, such occasions being separated by an interval of not less than 4 months, and if both certificates are appropriate to those functions.

(b) A certificate of test required by Article 20(5) of this Order shall not be valid in relation to a flight made more than 13 months in the case of an instrument rating (aeroplanes) and an assistant flying instructor's rating or more than 25 months in the case of an instrument meteorological conditions rating (aeroplanes) and a flying instructor's rating, after the date of the test which it certifies.

#### *Certificate of experience*

**5.** A certificate of experience required by Article 20(4) of this Order shall be signed by a person authorised by the Minister to sign such a certificate and shall certify the following particulars:

- (a) the functions to which the certificate relates;
- (b) in the case of a pilot or flight engineer, that on the date on which the certificate was signed the holder of the licence or personal flying logbook of which it forms part, as the case may be, produced his personal flying logbook to the person signing the certificate and satisfied him that he had appropriate experience in the capacity to which his licence relates within the appropriate period specified in paragraph 6 of this Part of this Schedule.
- (c) in the case of a flight navigator that on the date on which the certificate was signed the holder of the licence of which it forms part produced his navigation logs, charts and workings of astronomical observations to the

person signing the certificate and satisfied him that he had appropriate experience in the capacity to which the licence relates within the appropriate period specified in paragraph 6 of this Part of this Schedule;

- (d) in the case of a pilot or flight engineer the type or types of aircraft in which the experience was gained;
- (e) the date on which it was signed.

*Period of experience*

**6.** A certificate of experience shall not be valid unless the experience certified was gained within the period of 13 months preceding the signing of the certificate in the case of Cases A, E, F and H, or 6 months preceding the signing of the certificate in the case of Case D.

*Period of Validity of Certificate of Experience*

**7.** A certificate of experience shall not be valid more than 6 months after it was signed for Case D nor more than 13 months after it was signed for any other Case.

SCHEDULE 10

Article 62(2)

AIR TRAFFIC CONTROLLERS: RATINGS

**1.** The holder of a licence which includes ratings of two or more of the classes specified in paragraph 2 of this Schedule shall not at any one time perform the functions specified in respect of more than one of those ratings;

Provided that the functions of any one of the following groups of ratings may be exercised at the same time:

- (a) The Aerodrome Control Rating and the Approach Control Rating;
- (b) The Approach Control Rating and the Approach Radar Control Rating; except that the functions of the Approach Control Rating shall not be exercised at the same time as the functions of the Approach Radar Control Rating if the service being provided under the latter is a surveillance radar approach terminating at a point less than 2 nautical miles from the point of intersection of the glide path with the runway;
- (c) The Area Control Rating and the Area Radar Control Rating.

**2.** Ratings of the following classes may be included in an air traffic controller's licence (other than a student air traffic controller's licence) granted under Article 61 of

the Order and, subject to the provisions of this Order and of the licence, the inclusion of a rating in a licence shall have the consequences respectively specified as follows:

- (1) Aerodrome Control Rating shall entitle the holder of the licence, at any aerodrome for which the rating is valid, to provide air traffic control service (but not with any type of radar equipment for which a radar control rating is required under this paragraph) for any aircraft on the manoeuvring area or apron of that aerodrome or which is flying in the vicinity of the aerodrome traffic zone by visual reference to the surface.
- (2) Approach Control Rating shall entitle the holder of the licence, at any aerodrome for which the rating is valid, to provide air traffic control service (but not with any type of radar equipment for which a radar control rating is required under this paragraph) for any aircraft which is flying in the vicinity of the aerodrome traffic zone whether or not it is flying by visual reference to the surface.
- (3) Approach Radar Control Rating shall entitle the holder of the licence, at any aerodrome at which the rating is valid, to provide air traffic control service with the aid of any type of surveillance radar equipment for which the rating is valid for any aircraft which is flying within 40 nautical miles of the aerodrome traffic zone whether or not it is flying by visual reference to the surface.
- (4) Precision Approach Radar Control Rating shall entitle the holder of the licence, at any aerodrome for which the rating is valid, to provide air traffic control service with the aid of any type of precision approach radar equipment for which the rating is valid.
- (5) Area Control Rating shall entitle the holder of the licence at any place for which the rating is valid to provide an air traffic control service without the aid of any surveillance radar equipment.
- (6) Area Radar Control Rating shall entitle that the holder of the licence, at any place for which the rating is valid, to provide air traffic control service with the aid of any type of surveillance radar equipment for which the rating is valid.

## SCHEDULE 11

### PUBLIC TRANSPORT - OPERATIONAL REQUIREMENTS

#### Article 25

##### PART A. - OPERATIONS MANUAL

Information and instructions relating to the following matters shall be included in the operations manual referred to in Article 25(2) of this Order:

- (i) the number of the crew to be carried in the aircraft, on each stage of any route to be flown, and the respective capacities in which they are to act, and instructions as to the order and circumstances in which command is to be assumed by members of the crew;
- (ii) the respective duties of each member of the crew and the other members of the operating staff;
- (iii) any particulars required to be entered by a scheme approved under Article 51 of this Order;
- (iv) such technical particulars concerning the aircraft, its engines and equipment and concerning the performance of the aircraft as may be necessary to enable the flight crew of the aircraft to perform their respective duties;
- (v) the manner in which the quantities of fuel and oil to be carried by the aircraft are to be computed and records of fuel and oil carried and consumed on each stage of the route to be flown are to be maintained; the instructions shall take account of all circumstances likely to be encountered on the flight including the possibility of failure of one or more of the aircraft engines;
- (vi) the manner in which the quantity, if any, of oxygen and oxygen equipment to be carried in the aircraft for the purpose of complying with Scale K in Schedule 5 to this Order is to be computed;
- (vii) the check system to be followed by the crew of the aircraft prior to and on take-off, on landing and in an emergency, so as to ensure that the operating procedures contained in the operations manual and in the flight manual or performance schedule forming part of the relevant certificate of airworthiness are complied with;
- (viii) the circumstances in which a radio watch is to be maintained;
- (ix) the circumstances in which oxygen is to be used by the crew of the aircraft, and by passengers;
- (x) communication, navigational aids, aerodromes, local regulations, in-flight procedures, approach and landing procedures and such other information as the operator may deem necessary for the proper conduct of flight operations; the information referred to in this paragraph shall be contained in a route guide, which may be in the form of a separate volume;
- (xi) the reporting in flight to the notified authorities of meteorological observations;
- (xii) the minimum altitudes for safe flight on each stage of the route to be flown and any planned diversion therefrom, such minimum altitudes being not

lower than any which may be applicable under the law of Seychelles or of the countries whose territory is to be flown over;

(xiii) the particulars referred to in Article 30 of this Order;

(xiv) emergency flight procedures, including procedures for the instruction of passengers in the position and use of emergency equipment and procedures to be adopted when the commander of the aircraft becomes aware that another aircraft or a vessel is in distress and needs assistance;

(xv) in the case of aircraft intended to fly at an altitude of more than 49,000 feet, the procedures for the use of cosmic radiation detection equipment:

Provided that in relation to any flight which is not one of a series of flights between the same two places it shall be sufficient if, to the extent that it is not practicable to comply with paragraphs (x) and (xii), the manual contains such information and instructions as will enable the equivalent data to be ascertained before take-off.

## PART B. - CREW TRAINING AND TESTS

### Article 27

**1.** The training, experience, practice and periodical tests required under Article 27(2) of this Order in the case of members of the crew of an aircraft engaged on a flight for the purpose of public transport shall be as follows:

(1) *The Crew*

Every member of the crew shall -

- (a) have been tested within the relevant period by or on behalf of the operator as to his knowledge of the use of the emergency and life saving equipment required to be carried in the aircraft on the flight; and
- (b) have practised within the relevant period under the supervision of the operator or of a person appointed by him for the purpose, the carrying out of the duties required of him in case of an emergency occurring to the aircraft, either in an aircraft of the type to be used on the flight or in apparatus approved by the Minister for the purpose and controlled by persons so approved.

(2) *Pilots*

- (a) Every pilot included in the flight crew who is intended by the operator to fly as pilot in circumstances requiring compliance with the Instrument Flight Rules shall within the relevant period have been tested by or on behalf of the operator-

- (i) as to his competence to perform his duties while executing normal manoeuvres and procedures in flight, in an aircraft of the type to be used on the flight, including the use of the instruments and equipment provided in the aircraft;
- (ii) as to his competence to perform his duties in instrument flight conditions while executing emergency manoeuvres and procedures in flight, in an aircraft of the type to be used on the flight, including the use of the instruments and equipment provided in the aircraft.

A pilot's ability to carry out normal manoeuvres and procedures shall be tested in the aircraft in flight.

The other tests required by this sub-paragraph may be conducted either in the aircraft in flight, or under the supervision of a person approved by the Minister for the purpose by means of a flight simulator approved by the Minister under Article 20 (10) of this Order. The test specified in sub-paragraph (2) (a) (ii) of this paragraph when conducted in the aircraft in flight shall be carried out either in actual instrument flight conditions or in instrument flight conditions simulated by means approved by the Minister.

- (b) Every pilot included in the flight crew whose licence does not include an instrument rating or who, notwithstanding the inclusion of such a rating in his licence, is not intended by the operator to fly in circumstances requiring compliance with the Instrument Flight Rules, shall within the relevant period have been tested, by or on behalf of the operator in flight in an aircraft of the type to be used on the flight:
  - (i) as to his competence to act as pilot thereof, while executing normal manoeuvres and procedures, and
  - (ii) as to his competence to act as pilot thereof while executing emergency manoeuvres and procedures.

### (3) *Flight Engineers*

Every flight engineer included in the flight crew shall within the relevant period have been tested by or on behalf of the operator either in flight or under the supervision of a person approved by the Minister for the purpose, by means of a flight simulator approved by the Minister under Article 20 (10) of this Order as to his competence to perform the duties of flight engineer in aircraft of the type to be used on the flight, including his ability to execute emergency procedures in the course of such duties.

### (4) *Flight Navigators and Flight Radio Operators*

Every flight navigator and flight radio operator whose inclusion in the flight crew is required under Article 18 (4) and (5) respectively of this Order shall within the relevant period have been tested by or on behalf of the operator as to his competence to perform his duties in conditions corresponding to those likely to be encountered on the flight-

- (a) in the case of a flight navigator, using equipment of the type to be used in the aircraft on the flight for the purposes of navigation;
  - (b) in the case of a flight radio operator using radio equipment of the type installed in the aircraft to be used on the flight, and including a test of his ability to carry out emergency procedures.
- (5) *Aircraft Commanders*
- (a) The pilot designated as commander of the aircraft for the flight shall within the relevant period -
    - (i) have demonstrated to the satisfaction of the operator that he has adequate knowledge of the route to be taken, the aerodromes of take-off and landing, and any alternate aerodromes, including in particular his knowledge of -
      - the terrain,
      - the seasonal meteorological conditions,
      - the meteorological communications, and air traffic facilities, services and procedures,
      - the search and rescue procedures, and
      - the navigational facilities,
      - relevant to the route;
    - (ii) have been tested as to his proficiency in using instrument approach-to-land systems of the type in use at the aerodrome of intended landing and any alternate aerodromes, such test being carried out either in flight in instrument flight conditions or in instrument flight conditions simulated by means approved by the Minister or under the supervision of a person approved by the Minister for the purpose by means of a flight simulator approved by the Minister under Article 20(10) of this Order;
    - (iii) have carried out as pilot in command not less than three take-offs and three landings in aircraft of the type to be used on the flight.
  - (b) In determining whether a pilot's knowledge of the matters referred to in sub-paragraph (a)(i) is sufficient to render him competent to perform the duties of aircraft commander on the flight, the operator shall take into account the pilot's flying experience in conjunction with the following-
    - (i) the experience of other members of the intended flight crew;

- (ii) the influence of terrain and obstructions on departure and approach procedures at the aerodromes of take-off and intended landing and at alternate aerodromes;
- (iii) the similarity of the instrument approach procedures and let-down aids to those with which the pilot is familiar;
- (iv) the dimensions of runways which may be used in the course of the flight in relation to the performance limits of aircraft of the type to be used on the flight;
- (v) the reliability of meteorological forecasts and the probability of difficult meteorological conditions in the areas to be traversed;
- (vi) the adequacy of the information available regarding the aerodrome of intended landing and any alternate aerodromes;
- (vii) the nature of air traffic control procedures and familiarity of the pilot with such procedures;
- (viii) the influence of terrain on route conditions and the extent of the assistance obtainable en route from navigational aids and air-to-ground communication facilities;
- (ix) the extent to which it is possible for the pilot to become familiar with unusual aerodrome procedures and features of the route by means of ground instruction and training devices.

(6) For the purposes of this paragraph -

"instrument flight conditions" means weather conditions such that the pilot is unable to fly by visual reference to object outside the aircraft;

"relevant period" means a period which immediately precedes the commencement of the flight, being a period -

- (a) in the case of sub-paragraph (5)(a)(iii) of this paragraph, of 3 months;
- (b) in the case of sub-paragraphs (2)(a)(ii), (2)(b)(ii), (3) and (5)(a)(ii) of this paragraph, of 6 months;
- (c) in the case of sub-paragraphs (1), (2)(a)(i), (2)(b)(i), (4) and (5)(a)(i) of this paragraph, of 13 months:

Provided that -

- (i) any pilot of the aircraft to whom the provisions of sub-paragraphs (2)(a)(ii), (2)(b)(ii), or (5)(a)(ii) and any flight engineer of the aircraft to whom the



provisions of sub-paragraph (3) of this paragraph apply shall for the purposes of the flight be deemed to have complied with such requirements respectively within the relevant period if he has qualified to perform his duties in accordance therewith on two occasions within the period of 13 months immediately preceding the flight, such occasions being separated by any interval of not less than 4 months;

- (ii) the requirements of sub-paragraphs (5)(a)(i) shall be to have been complied with within the relevant period by a pilot designated as commander of the aircraft for the flight if, having become qualified so to act on flights between the same places over the same route more than 13 months before commencement of the flight, he has within the period of 13 months immediately preceding the flight flown as pilot of an aircraft between those places over that route.

2 (1) The records required to be maintained by an operator under Article 27(2) of this Order shall be accurate and up-to-date records so kept as to show, on any date, in relation to each person who has during the period of two years immediately preceding that date flown as a member of the crew of any public transport aircraft operated by that operator-

- (a) the date and particulars of each test required by this Schedule undergone by that person during the said period including the name and qualifications of the examiner;
- (b) the date upon which that person last practised the carrying out of duties referred to in paragraph 1(1)(b) of this Schedule;
- (c) the operator's conclusions based on each such test and practice as to that person's competence to perform his duties;
- (d) the date and particulars of any decision taken by the operator during the said period in pursuance of paragraph 1(5)(a)(i) of this Schedule including particulars of the evidence upon which that decision was based.

(2) The operator shall whenever called upon to do so by any authorised person produce for the inspection of any Person so authorised all records referred to in the preceding sub-paragraph and furnish to any such person all such information as he may require in connection with any such records and produce for his inspection all log books, certificates, papers and other documents, whatsoever which he may reasonably require to see for the purpose of determining whether such records are complete or of verifying the accuracy of their contents.

(3) The operator shall at the request of any person in respect of whom he is required to keep records as aforesaid furnish to that person, or to any operator of aircraft for the purpose of public transport by whom that person may subsequently be

employed, particulars of any qualifications in accordance with this Schedule obtained by such person whilst in his service.

#### PART C. - TRAINING MANUAL

The following information and instructions in relation to the training, experience, practice and periodical tests required under Article 27(2) of this Order shall be included in the training manual referred to in Article 26(2) of this Order -

- (i) the manner in which the training, practice and periodical tests required under Article 27(2) and specified in Part B of Schedule 11 to this Order are to be carried out;
- (ii) (a) the minimum qualifications and experience which the operator requires of persons appointed by him to give or to supervise the said training practice and periodical tests; and
  - (b) the type of training, practice and periodical tests which each such person is appointed to give or to supervise; and
  - (c) the type of aircraft in respect of which each

such person is appointed to give or to supervise the said training, practice and periodical tests;

- (iii) the minimum qualifications and experience required of each member of the crew undergoing the said training, practice and periodical tests;
- (iv) the syllabus for, and specimen forms for recording, the said training, practice and periodical tests;
- (v) the manner in which instrument flight conditions and engine failure are to be simulated in the aircraft in flight;
- (vi) the extent to which the said training and testing is permitted in the course of flights for the purpose of public transport;
- (vii) the use to be made in the said training and testing apparatus approved for the purpose by the Minister.

#### SCHEDULE 12

Articles 54 and 56

#### DOCUMENTS TO BE CARRIED BY AIRCRAFT

#### REGISTERED IN SEYCHELLES

On a flight for the purpose of public transport:

Documents A, B, C, D, E, F, H, and, if the flight is international air navigation, Document G.

On a flight for the purpose of the public transport of passengers: Document J.

On a flight for the purpose of aerial work:

Documents A, B, C, D, E, F, and, if the flight is international air navigation Document G.

On a flight, being international air navigation, for a purpose other than public transport or aerial work;

Document A, B, C and G.

For the purpose of this Schedule:

"A" means the licence in force in respect of the aircraft radio station installed in the aircraft, and the current telecommunication log book required by his Order;

"B" means the certificate of airworthiness in force in respect of the aircraft;

"C" means the licences of the members of the flight crew of the aircraft;

"D" means one copy of the load sheet, if any, required by Article 28 of this Order in respect of the flight;

"E" means one copy of each certificate of maintenance, if any, in force in respect of the aircraft.

"F" means the technical log, if any, in which entries are required to be made under Article 9(6) and the log book, if any, in which entries are required to be made under Article 10(5) of this order;

"G" means the certificate of registration in force in respect of the aircraft;

"H" means the operations manual, if any, required by Article 25(2)(a)(iii) of this Order to be carried on the flight;

"J" means one copy of the certificate of release, if any, in force in respect of the aircraft.

For the purpose of this Schedule:

"International air navigation" means any flight in which a landing is made outside the Territory or State in which the aircraft commences the flight.

## SCHEDULE 13

Article 84

## PENALTIES

### PART A - PROVISIONS REFERRED TO IN ARTICLE 84(5)

Article 3.	Article 47.
Article 5.	Article 51(3).
Article 11(2) and (5).	Article 64(2).
Article 15.	Article 68(4).
Article 16(3).	Article 70.
Article 23.	Article 74.
Article 28(5).	Article 75(1) and (2).
Article 35.	Article 82.
Article 36(2).	

### PART B - PROVISIONS REFERRED TO IN ARTICLE 84(6)

Article 6.	Article 36(1).
Article 7.	Article 37 to 46 inclusive.
Article 9(1)	Article 48.
Article 10(1).	Article 49.
Article 11 (except paragraphs (2) and (5)).	Article 50(1) and (2).
Article 13.	Article 59 (except paragraph (3)).
Article 14.	Article 60 (except paragraph (4)).
Article 16 (except paragraph (3)).	Article 62 (except paragraph (4)).
Article 18.	Article 64 (except paragraph (2)).
Article 19.	Article 65.

Article 25.	Article 66.
Article 26.	Article 69.
Article 27.	Article 78.
Article 28 (except paragraph (5)).	Article 79.
Articles 29 to 34, inclusive.	Article 80.

#### SCHEDULE 14.

#### RULES OF THE AIR AND AIR TRAFFIC CONTROL

Article 60.

#### SECTION I

#### INTERPRETATION

**1.** In these Rules, unless the context otherwise requires -

"Air traffic control clearance" means authorisation by an air traffic control unit for an aircraft to proceed under conditions specified by that unit.

"Anti-collision light" means a flashing red light showing in all directions for the purpose of enabling the aircraft to be more readily detected by the pilots of distant aircraft.

"Apron" means the part of an aerodrome provided for the stationing of aircraft for the embarkation and disembarkation of passengers, the loading and unloading of cargo and for parking.

"Ground visibility" means the horizontal visibility at ground level.

"IFR flight" means a flight conducted in accordance with the Instrument flight Rules in Section VI of these Rules.

"Manoeuvring area" means the part of an aerodrome provided for the take-off and landing of aircraft and for the movement of aircraft on the surface, excluding the apron and any part of the aerodrome provided for the maintenance of aircraft.

"Runway" means an area, whether or not paved, which is provided for the take-off or landing of aircraft.

"VFR Flight" means a flight conducted in accordance with the Visual Flight Rules in Section V of these Rules.

## SECTION II

### GENERAL

#### *Application of Rules to aircraft*

2. These Rules, in so far as they are applicable in relation to aircraft, shall, subject to the provisions of Rule 29 of these Rules, apply in relation to -

- (a) all aircraft within Seychelles; and
- (b) all aircraft registered in Seychelles, wherever they may be.

#### *Misuse of Signals and Markings*

3 (1) A signal or marking to which a meaning is given by these Rules, or which is required by these Rules to be used in circumstances or for a purpose therein specified, shall not be used except with that meaning, or for that purpose.

(2) A person in an aircraft or on an aerodrome or at any place at which an aircraft is taking off or landing shall not make any signal which may be confused with a signal specified in these Rules, and, except with lawful authority, shall not make any signal which he knows or ought reasonably to know to be a signal in use for signalling to or from any of the naval or military or air force aircraft of the Republic of Seychelles.

#### *Reporting hazardous conditions*

4. The commander of an aircraft shall, on meeting with hazardous conditions in the course of a flight, or as soon as possible thereafter, send to the appropriate air traffic control unit by the quickest means available information containing such particulars of the hazardous conditions as may be pertinent to the safety of other aircraft.

#### *Low Flying*

5 (1) Subject to the provisions of paragraphs (2) and (3) of this Rule:

- (a) An aircraft other than a helicopter shall not fly over any congested area of a city, town or settlement below-
  - (i) such height as would enable the aircraft to alight clear of the area and without danger to persons or property on the surface, in the event of failure of a power unit; or
  - (ii) a height of 1,500 feet above the highest fixed object within 2,000 feet of the aircraft,

whichever is the higher.

- (b) A helicopter shall not fly below such height as would enable it to alight without danger to persons or property on the surface, in the event of failure of the power unit.
- (c) Except with the permission in writing of the Minister and in accordance with any conditions therein specified a helicopter shall not fly over a congested area of a city, town or settlement below a height of 1,500 feet above the highest fixed object within 2,000 feet of the helicopter.
- (d) An aircraft shall not fly -
  - (i) over, or within 3,000 feet of, any assembly in the open air of more than 1,000 persons assembled for the purpose of witnessing or participating in any organised event, except with the permission in writing of the Minister and in accordance with any conditions therein specified and with the consent in writing of the organisers of the event; or
  - (ii) below such height as would enable it to alight clear of the assembly in the event of the failure of a power unit:

Provided that where a person is charged with an offence under this Order by reason of a contravention of this sub-paragraph, it shall be a good defence to prove that the flight of the aircraft over, or within 3,000 feet of, the assembly was made at a reasonable height and for a reason not connected with the assembly or with the event which was the occasion for the assembly.

- (e) An aircraft shall not fly closer than 500 feet to any person, vessel, vehicle or structure.

(2) (a) The provisions of paragraphs (1)(a)(ii) and (1)(c) of this Rule shall not apply to an aircraft flying -

- (i) on a route notified for the purposes of this Rule, or
  - (ii) on a special VFR flight as defined in Rule 23 of these Rule in accordance with instructions given for the purposes of that Rule by the appropriate air traffic control unit.
- (b) Paragraphs (1)(d) and (e) of this Rule shall not apply to an aircraft which is being used for police purposes.
  - (c) Paragraphs (1)(d) and (e) of this Rule shall not apply to the flight of an aircraft over or within 3,000 feet of an assembly of persons gathered for the purpose of witnessing an event which consists

wholly or principally of an aircraft race or contest or an exhibition of flying, if the aircraft is taking part in such race, contest or exhibition or is engaged on a flight arranged by, or made with the consent in writing of, the organisers of the event.

- (d) Paragraph (1)(e) of this Rule shall not apply to -
- (i) any aircraft while it is landing or taking off in accordance with normal aviation practice;
  - (ii) any glider while it is hill-soaring;
  - (iii) any aircraft while it is flying in accordance with proviso (f) of Article 39(2) of this Order.

(3) Nothing in this Rule shall prohibit an aircraft from flying in such a manner as is necessary for the purpose of saving life.

(4) Nothing in this Rule shall prohibit any aircraft from flying in accordance with normal aviation practice, for the purpose of taking off from, landing at or practising approaches to landing at, or checking navigational aids or procedures at, a Government aerodrome or a licensed aerodrome in Seychelles or at any aerodrome in any other country:

Provided that the practising of approaches to landing shall be confined to the airspace customarily used by aircraft when landing or taking off in accordance with normal aviation practice at the aerodrome concerned.

(5) Nothing in this rule shall apply to any captive balloon or kite.

*Simulated instrument flight.*

- 6.** An aircraft shall not be flown in simulated instrument flight conditions unless -
- (a) the aircraft is fitted with dual controls which are functioning properly;
  - (b) an additional pilot (in this Rule called "a safety pilot") is carried in a second control seat of the aircraft for the purpose of rendering such assistance as may be necessary to the pilot flying the aircraft; and
  - (c) if the safety pilot's field of vision is not adequate both forward and to each side of the aircraft, a third person, being a competent observer, occupies a position in the aircraft which from his field of vision makes good the deficiencies in that of the safety pilot, and from which he can readily communicate with the safety pilot.



For the purposes of this Rule the expression "simulated instrument flight" means a flight during which mechanical or optical devices are used in order to reduce the field of vision or the range of visibility from the cockpit of the aircraft.

*Practice Instrument Approaches*

7. Within Seychelles an aircraft shall not carry out instrument approach practice when flying in Visual Meteorological Conditions unless-

- (a) the appropriate air traffic control unit has previously been informed that the flight is to be made for the purpose of instrument approach practice; and
- (b) if the flight is not being carried out in simulated instrument flight conditions, a competent observer is carried in such a position in the aircraft that he has an adequate field of vision and can readily communicate with the pilot flying the aircraft.

SECTION III

LIGHTS AND OTHER SIGNALS TO BE SHOWN OR MADE BY AIRCRAFT

*General*

8 (1) For the purposes of this Section of these Rules the horizontal plane of a light shown in an aircraft means the plane which would be the horizontal plane passing through the source of that light, if the aircraft were in level flight.

(2) Where by reason of the physical construction of an aircraft it is necessary to fit more than one lamp in order to show a light required by this Section of these Rules, the lamps shall be so fitted and constructed that, so far as is reasonably practicable, not more than one such lamp is visible from any one point outside the aircraft.

(3) Where in these Rules a light is required to show through specified angles in the horizontal plane, the lamps giving such light shall be so constructed and fitted that the light is visible from any point in any vertical plane within those angles throughout angles of 90° above and below the horizontal plane, but, so far as is reasonably practicable, through no greater angle, either in the horizontal plane or the vertical plane.

(4) Where in these Rules a light is required to show in all directions, the lamps giving such light shall be so constructed and fitted that, so far as is reasonably practicable, the light is visible from any point in the horizontal plane and on any vertical plane passing through the source of that light.

*Display of Lights by Aircraft*

**9** (1) By night an aircraft shall display such of the lights specified in these Rules as may be appropriate to the circumstances of the case, and shall not display any other lights which might obscure or otherwise impair the visibility of, or be mistaken for, such lights:

Provided that nothing in this paragraph shall prevent the display of an anti-collision light.

(2) A flying machine on a land aerodrome in Seychelles at which aircraft normally land or take off at night shall, unless it is stationary on the apron or a part of the aerodrome provided for the maintenance of aircraft, display by night either the lights which it would be required to display if it were flying, or the lights specified in Rule 11(2)(a) or 11(2)(c) of these Rules.

#### *Failure of Navigation Lights*

**10.** In Seychelles, in the event of the failure of any light which is required by these Rules to be displayed in flight, if the light cannot be immediately repaired or replaced the aircraft shall land as soon as in the opinion of the commander of the aircraft it can safely do so, unless authorised by the appropriate air traffic control unit to continue its flight.

#### *Flying Machines*

**11** (1) A flying machine when flying at night shall display lights as follows:

- (a) in the case of a flying machine registered in Seychelles having a maximum total weight authorised of more than 5,700 kg. the system of lights specified in paragraph (2)(b) of this Rule;
- (b) in the case of a flying machine registered in Seychelles having a maximum total weight authorised of 5,700 kg. or less, any one of the following systems of lights -
  - (i) that specified in paragraph (2)(a) of the Rule, or that specified in paragraph (2)(b); or
  - (ii) that specified in paragraph (2)(b), excluding sub- paragraph (ii);
- (c) in the case of any other flying machine one of the systems of lights specified in paragraph (2) of this Rule.

(2) The systems of lights referred to in paragraph (1) of this Rule are as follows:

- (a) (i) a green light of at least five candela showing to the starboard side through an angle of 110° from dead ahead in the horizontal plane; and
- (ii) a red light of at least five candela showing to the port side through an angle of 110° from dead ahead in the horizontal plane; and
- (iii) a white light of at least three candela showing through angles of 70° from dead astern to each side in the horizontal plane,

all being steady lights;

- (b) (i) the lights specified in sub-paragraph (a) of this paragraph; and
- (ii) an anti-collision light;
- (c) the lights specified in sub-paragraph (a) of this paragraph, but all being flashing lights flashing together;
- (d) the lights specified in sub-paragraph (a) of this paragraph, but all being flashing lights flashing together in alternation with one or both of the following:
  - (i) a flashing white light of at least twenty candela showing in all directions;
  - (ii) a flashing red light of at least twenty candela showing through angles of 70° from dead astern to each side in the horizontal plane.

(3) If the lamp showing either the red or the green light specified in paragraph (2) (a) of this Rule is fitted more than 2 metres from the wing tip, a lamp may notwithstanding the provisions of Rule 9(1) of these Rules, be fitted at the wing tip to indicate its position showing a steady light of the same colour through the same angle.

#### *Gliders*

**12.** A glider while flying at night shall display either a steady red light of at least five candela, showing in all directions, or lights in accordance with Rule 11(2) and (3) of these Rules.

#### *Free Balloons*

**13.** A free balloon while flying at night shall display a steady red light of at least five candela showing in all directions, suspended not less than 5 metres and not more than 10 metres below the basket, or if there is no basket, below the lowest part of the balloon.

### *Captive Balloon and Kites*

**14** (1) A captive balloon or kite while flying at night at a height exceeding 60 metres above the surface shall display lights as follows:

- (a) a group of two steady lights consisting of a white light placed 4 metres above a red light, both being of at least five candela and showing in all directions, the white light being placed not less than 5 metres or more than 10 metres below the basket, or if there is no basket, below the lowest part of the balloon or kite;
- (b) on the mooring cable, at intervals of not more than 300 metres measured from the group of lights referred to in sub-paragraph (a) of this paragraph, groups of two lights of the colour and power and in the relative positions specified in that sub-paragraph, and, if the lowest group of lights is obscured by cloud, an additional group below the cloud base; and
- (c) on the surface, a group of three flashing lights arranged in a horizontal plane at the apexes of a triangle, approximately equilateral, each side of which measures at least 25 metres; one side of the triangle shall be approximately at right angles to the horizontal projection of the cable and shall be delimited by two red lights; the third light shall be a green light so placed that the triangle encloses the object on the surface to which the balloon or kite is moored.

(2) A captive balloon while flying by day at a height exceeding 60 metres above the surface shall have attached to its mooring cable at intervals of not more than 200 metres measured from the basket, or, if there is no basket, from the lowest part of the balloon, tubular streamers not less than 40 centimetres in diameter and 2 metres in length, and marked with alternate bands of red and white 50 centimetres wide.

(3) A kite flown in the circumstances referred to in paragraph (2) of this Rule shall have attached to its mooring cable either:

- (a) tubular streamers as specified in paragraph (2) of this Rule; or
- (b) at intervals of not more than 100 metres measured from the lowest part of the kite, streamers of not less than 80 centimetres long and 30 centimetres wide at their widest point and marked with alternate bands of red and white 10 centimetres wide.

### *Airships*

**15** (1) Except as provided in paragraph (2) of this Rule, an airship while flying at night shall display the following steady lights:

- (a) a white light of at least five candela showing through angles of 110° from dead ahead to each side in the horizontal plane;
- (b) a green light of at least five candela showing to the starboard side through an angle of 110° from dead ahead in the horizontal plane;
- (c) a red light of at least five candela showing to the port side through an angle of 110° from dead ahead in the horizontal plane; and
- (d) a white light of at least five candela showing through angles of 70° from dead astern to each side in the horizontal plane.

(2) An airship while flying at night shall display, if it is not under command, or has voluntarily stopped its engines, or being towed, the following steady lights:

- (a) the white lights referred to in paragraph (1)(a) and (d) of this Rule;
- (b) two red lights, each of at least five candela and showing in all directions suspended below the control car so that one is at least 4 metres above the other and at least 8 metres below the control car; and
- (c) if the aircraft is making way but not otherwise, the green and red lights referred to in paragraph (1)(b) and (c) of this Rule:

Provided that an airship while picking up its moorings, notwithstanding that it is not under command, shall display only the lights specified in paragraph (1) of this Rule.

(3) An airship, while moored within Seychelles by night, shall display the following lights:

- (a) when moored to a mooring mast, at or near the rear a white light of at least five candela showing in all directions;
- (b) when moored otherwise than to a mooring mast:
  - (i) a white light of at least five candela showing through angles of 110° from dead ahead to each side in the horizontal plane;
  - (ii) a white light of at least five candella showing through angles of 70° from dead astern to each side in the horizontal plane.

(4) An airship while flying by day, if it is not under command, or has voluntarily stopped its engines, or is being towed, shall display two black balls suspended below the control car so that one is at least 4 metres above the other and at least 8 metres below the control car.

(5) For the purposes of this Rule:

- (a) an airship shall be deemed not to be under command when it is unable to execute a manoeuvre which it may be required to execute by or under these Rules;
- (b) an airship shall be deemed to be making way when it is not moored and is in motion relative to the air.

## SECTION IV

### GENERAL FLIGHT RULES

#### *Weather reports and forecasts*

**16** (1) Immediately before an aircraft flies the commander of the aircraft shall examine the current reports and forecasts of the weather conditions on the proposed flight path, being reports and forecasts which it is reasonably practicable for him to obtain, in order to determine whether Instrument Meteorological Conditions prevail or are likely to prevail during any part of the flight.

(2) An aircraft which is unable to communicate by radio with an air traffic control until at the aerodrome of destination shall not begin a flight to an aerodrome within a control zone if the information which it is reasonably practicable for the commander of the aircraft to obtain indicates that it will arrive at that aerodrome when the ground visibility is less than five nautical miles or the cloud ceiling is less than 1,500 feet, unless the commander of the aircraft has obtained from an air traffic control unit at that aerodrome permission to enter the aerodrome traffic zone.

#### *Rules for avoiding aerial collisions*

##### **17** (1) General

- (a) Notwithstanding that the flight is being made with air traffic control clearance it shall remain the duty of the commander of an aircraft to take all possible measures to ensure that his aircraft does not collide with any other aircraft.
- (b) An aircraft shall not be flown in such proximity to other aircraft as to create a danger of collision.
- (c) Aircraft shall not fly in formation unless the commanders of the aircraft have agreed to do so.
- (d) An aircraft which is obliged by these Rules to give way to another aircraft shall avoid passing over or under the other aircraft, or crossing ahead of it, unless passing well clear of it.
- (e) An aircraft which has the right-of-way under the Rule shall maintain its course and speed.

- (f) For the purposes of this Rule a glider and a flying machine which is towing it shall be considered to be a single aircraft under the command of the commander of the towing flying machine.

*Converging*

- (a) Subject to the provisions of paragraphs (3) and (4) of this Rule, an aircraft in the air shall give way to other converging aircraft as follows :
  - (i) flying machines shall give way to airships, gliders and balloons;
  - (ii) airships shall give way to gliders and balloons;
  - (iii) gliders shall give way to balloons.
- (b) Subject to the provisions of sub-paragraph (a) of this paragraph, when two aircraft are converging in the air at approximately the same altitude, the aircraft which has the other on its right shall give way:

Provided that mechanically driven aircraft shall give way to aircraft which are towing other aircraft or objects.

(3) *Approaching Head-on*

When two aircraft are approaching head-on or approximately so in the air and there is danger of collision, each shall alter its course to the right.

(4) *Overtaking*

An aircraft which is being overtaken in the air shall have the right-of-way and the overtaking aircraft, whether climbing, descending or in horizontal flight, shall keep out of the way of the other aircraft by altering course to the right, and shall not cease to keep out of the way of the other aircraft until that other aircraft has been passed and is clear, notwithstanding any change in the relative positions of the two aircraft:

Provided that a glider overtaking another glider in Seychelles may alter its course to the right or to the left.

(5) *Landing*

An aircraft while landing or on final approach to land shall have the right-of-way over other aircraft in flight or on the ground or water.

(6) *Two or more aircraft landing*

In the case of two or more flying machines or gliders approaching any place for the purpose of landing, the aircraft at the lower altitude shall have the right-of-way, but it

shall not cut in front of another aircraft which is on final approach to land or overtake that aircraft:

Provided that:

- (a) when an air traffic control unit has communicated to any aircraft an order of priority for landing, the aircraft shall approach to land in that order, and
- (b) when the commander of an aircraft is aware that another aircraft is making an emergency landing, he shall give way to that aircraft, and at night, notwithstanding that he may have received permission to land, shall not attempt to land until he has received further permission to do so.

#### *Aerobatic Manoeuvres*

**18.** An aircraft shall not carry out any aerobatic manoeuvre-

- (a) over the congested area of any city, town or settlement; or
- (b) within controlled airspace except with the consent of the appropriate air traffic control unit.

#### *Right-hand Traffic Rule*

**19.** An aircraft which is flying within Seychelles in sight of the ground and following a road, railway, canal or coastline, or any other line of landmarks, shall keep such line of landmarks on its left.

#### *Notification of Arrival*

**20** (1) The commander of an aircraft entering or leaving Seychelles on any flight for which a flight plan has been submitted shall take all reasonable steps to ensure upon landing that notice of the arrival of the aircraft is given to the aerodrome of departure.

(2) The commander of an aircraft who has caused notice of its intended arrival at any aerodrome to be given to the air traffic control unit or other authority at that aerodrome shall ensure that the air traffic control unit or other authority at that aerodrome is informed as quickly as possible of any change of intended destination and any estimated delay in arrival of 45 minutes or more.

#### *Flight in Notified Airspace*

**21.** In relation to flights in Visual Meteorological Conditions in controlled airspace notified for the purposes of this Rule, the commander of an aircraft shall comply with Rules 27 and 28 of these Rules as if the flights were IFR flights:

Provided that the commander of the aircraft shall not elect to continue the flight in compliance with the Visual Flight Rules for the purposes of Rule 27(3).



*Choice of VFR or IFR*

**22.** Subject to the provisions of Rule 21 of these Rules an aircraft shall always be flown in accordance with the Visual Flight Rules or the Instrument Flight Rules:

Provided that in Seychelles an aircraft flying at night -

- (a) outside a control zone shall be flown in accordance with the Instrument Flight Rules; or
- (b) in a control zone shall be flown in accordance with the Instrument Flight Rules or the provisions of the proviso to Rule 23(b) of these Rules.

SECTION V

VISUAL FLIGHT RULES

**23.** The Visual Flight Rules shall be as follows:

(a) *Outside controlled airspace*

- (i) an aircraft flying outside controlled airspace above 3,000 feet above mean sea level shall remain at least one nautical mile horizontally and 1,000 feet vertically away from cloud and in a flight visibility of at least five nautical miles;
- (ii) an aircraft other than a helicopter flying outside controlled airspace at or below 3,000 feet above mean sea level shall remain at least one nautical mile horizontally and 1000 feet vertically away from cloud and in a flight visibility of three nautical miles:

Provided that this sub-paragraph shall be deemed to be complied with if the aircraft is flown at a speed which according to its air speed indicator is 140 knots or less and remains clear of cloud, in sight of the surface and in a flight visibility of at least one nautical mile;

- (iii) a helicopter flying outside controlled airspace at or below 3,000 feet above mean sea level shall remain clear of cloud and in sight of the surface, or at least one nautical mile horizontally and 1,000 feet vertically away from cloud and in a flight visibility of at least 3 nautical miles.

(b) *Within controlled airspace*

An aircraft flying within controlled airspace shall remain at least one nautical mile horizontally and 1,000 feet vertically away from cloud and in a flight visibility of at least five nautical miles:

Provided that in a control zone, in the case of a special VFR flight, the aircraft shall be flown in accordance with any instructions given by the appropriate air traffic control unit.

For the purposes of this Rule, "special VFR flight" means a flight made in Instrument Meteorological Conditions or at night in a control zone or in a control zone notified for the purposes of Rule 21 of these Rules, in respect of which the appropriate air traffic control unit has given permission for the flight to be made in accordance with special instructions given by that unit instead of in accordance with the Instrument Flight Rules.

(2) Where the Minister has notified increases in all or any of the distances mentioned in sub-paragraph (a) or (b) of paragraph (1) of this Rule, then such increased distances shall be deemed to be substituted for the distances mentioned in this Rule for so long as the notification concerned is in force.

## SECTION VI

### INSTRUMENT FLIGHT RULES

**24.** The Instrument Flight Rules shall be as follows:

(a) *Outside controlled airspace*

In relation to flights outside controlled airspace Rules 25 and 26 of these Rules shall apply.

(b) *Within controlled airspace*

In relation to flights within controlled airspace Rules 25, 27 and 28 of these Rules shall apply.

#### *Minimum Height*

**25.** Without prejudice to the provisions of Rule 5 of these Rules, in order to comply with the Instrument Flight Rules an aircraft shall not fly at a height of less than 1,000 feet above the highest obstacle within a distance of five nautical miles of the aircraft unless:

- (a) it is necessary for the aircraft to do so in order to take off or land; or
- (b) the aircraft is flying on a route notified for the purposes of this Rule; or
- (c) the aircraft has been otherwise authorised by the competent authority; or
- (d) the aircraft is flying at an altitude not exceeding 3,000 feet above mean sea level and remains clear of cloud and in sight of the surface.

*Quadrantal Rule and Semi-Circular Rule*

**26.** In order to comply with the Instrument Flight Rules an aircraft when in level flight above 3,000 feet above mean sea level outside controlled airspace shall be flown at a level appropriate to its magnetic track, in accordance with the appropriate table set forth in this Rule. The level of flight shall be measured by an altimeter set according to the system notified, or in the case of flight over a country other than Seychelles, otherwise published by the competent authority, in relation to the area over which the aircraft is flying:

Provided that an aircraft may be flown at a level other than the level required by this Rule if it is flying in conformity with instructions given by an air traffic control unit or in accordance with notified en-route holding patterns or in accordance with holding procedures notified in relation to an aerodrome.

*TABLE I - Flights at levels below 24,500 feet*

<i>Magnetic Track</i>	<i>Cruising Level</i>
Less than 90° ... ..	Odd thousands of feet.
90° but less than 180°...	Odd thousands of feet + 500 feet.
180° but less than 270°...	Even thousand of feet.
270° but less than 360°...	Even thousands of fee + 500 feet.

*TABLE II - Flights at levels above 24,500 feet*

<i>Magnetic Track</i>	<i>Cruising level</i>
Less than 180° ... ..	25,000 feet.
	27,000 feet.
	29,000 feet or higher levels at intervals of 4,000 feet.
180°but less than 360°	26,000 feet.
	28,000 feet.
	31,000 feet or higher levels at intervals of 4,000 feet.

*Flight Plan and Air Traffic Control Clearance*

**27** (1) In order to comply with the Instrument Flight Rules, before an aircraft either takes off from a point within any controlled airspace or otherwise flies within any

controlled airspace the commander of the aircraft shall cause a flight plan to be communicated to the appropriate air traffic control unit and shall obtain an air traffic control clearance based on such flight plan.

(2) The flight plan shall contain such particulars of the intended flight as may be necessary to enable the air traffic control unit to issue an air traffic control clearance, or for search and rescue purposes.

(3) The commander of the aircraft shall fly in conformity with -

- (a) the air traffic control clearance issued for the flight, as amended by any further instructions given by an air traffic control unit; and
- (b) the holding and instrument approach procedures notified in relation to the aerodrome of destination, unless he is otherwise authorised by the air traffic control unit there:

Provided that he shall not be required to comply with the foregoing provisions of this paragraph if:

- (i) he is able to fly in uninterrupted Visual Meteorological Conditions for so long as he remains in controlled airspace, and
- (ii) he has informed the appropriate air traffic control unit of his intention to continue the flight in compliance with Visual Flight Rules and has requested that unit to cancel his flight plan.

(4) If for the purpose of avoiding immediate danger any departure is made from the provisions of paragraph (3) of this Rule (as is permitted by Article 60(3) of the Order) the commander of the aircraft shall, in addition to causing particulars to be given in accordance with Article 60(4) of the Order, as soon as possible inform the appropriate air traffic control unit of the deviation.

(5) The commander of the aircraft after it has flown in controlled airspace shall, unless he has requested the appropriate air traffic control unit to cancel his flight plan, forthwith inform that unit when the aircraft lands within or leaves the controlled airspace.

#### *Position Reports*

**28** In order to comply with the Instrument Flight Rules the commander of an aircraft in IFR flight who flies in or is intending to enter controlled airspace shall report to the appropriate air control unit the time, and the position and altitude of the aircraft at such reporting points or at such intervals of time as may be notified for this purpose or as may be directed by the air traffic control unit.

## SECTION VII

## AERODROME TRAFFIC RULES

### *Application of Aerodrome Traffic Rules*

**29.** The Rules in this Section of these Rules which are expressed to apply to flying machines shall also be observed, so far as is practicable, in relation to all other aircraft.

### *Visual Signals*

**30.** The commander of a flying machine on, or in the traffic zone of, an aerodrome shall observe such visual signals as may be displayed at, or directed to him from the aerodrome by the authority of the person in charge of the aerodrome and shall obey any instructions which may be given to him by means of such signals:

Provided that he shall not be required to obey the signals referred to in Rule 45 of these Rules (Marshalling Signals) if in his opinion it is inadvisable to do so in the interests of safety.

### *Access to and movement on the Manoeuvring Area and other parts of the aerodrome used by aircraft*

**31** (1) A person or vehicle shall not go on to any part of an aerodrome provided for the use of aircraft and under the control of the person in charge of the aerodrome without the permission of the person in charge of the aerodrome, and except in accordance with any conditions subject to which that permission may have been granted.

(2) A vehicle or person shall not go or move on the manoeuvring area of an aerodrome having an air traffic control unit without the permission of that unit, and except in accordance with any conditions subject to which that permission may have been granted.

(3) Any permission granted for the purposes of this Rule may be granted either in respect of persons or vehicles generally, or in respect of any particular person or vehicle or any class of person or vehicle.

### *Right of Way on the ground*

- 32** (1) This Rule shall apply to -
- (a) flying machines; and
  - (b) vehicles

on any part of a land aerodrome provided for the use of aircraft and under the control of the person in charge of the aerodrome.

(2) Notwithstanding any air traffic control clearance it shall remain the duty of the commander of an aircraft to take all possible measures to ensure that his aircraft does not collide with any other aircraft or with any vehicle.

(3) (a) Flying machines and vehicles shall give way to aircraft which are taking off or landing.

(b) Vehicles, and flying machines which are not taking off or landing, shall give way to vehicles towing aircraft.

(c) Vehicles which are not towing aircraft shall give way to aircraft.

(4) Subject to the provisions of paragraph (3) of this Rule and of Rule 34(3)(b) of these Rules, in case of danger of collision between two flying machines -

(a) when the two flying machines are approaching head-on or approximately so, each shall alter its course to the right;

(b) when the two flying machines are on converging courses, the one which has the other on its right shall give way to the other and shall avoid crossing ahead of the other unless passing well clear of it;

(c) a flying machine which is being overtaken shall have the right-of-way, and the overtaking flying machine shall keep out of the way of the other flying machine by altering its course to the left until that other flying machine has been passed and is clear, notwithstanding any change in the relative positions of the two flying machines.

(5) Subject to the provisions of paragraph (3)(b) of this Rule a vehicle shall -

(a) overtake another vehicle so that the other vehicle is on the left of the overtaking vehicle;

(b) keep to the left when passing another vehicle which is approaching head-on or approximately so.

*Dropping of Tow Ropes, etc.*

**33.** Tow ropes, banners or similar articles towed by aircraft shall not be dropped from aircraft except at an aerodrome and:

(a) in accordance with arrangements made with an air traffic control unit at the aerodrome or, if there is no such unit, with the person in charge of the aerodrome; or

- (b) in the area designated by the marking described in Rule 42(7) of these Rules, and the ropes, banners or similar articles shall be dropped when the aircraft is flying in the direction appropriate for landing.

*Aerodromes not having Air Traffic Control Units*

**34** (1) (a) An aircraft shall not fly within a zone which the commander of the aircraft knows or ought reasonably to know to be the aerodrome traffic zone of an aerodrome where no air traffic control unit is for the time being notified as being on watch, except for the purpose of taking off or landing at that aerodrome or observing the signals in the signals area with a view to landing there, unless he has the permission of the person in charge of the aerodrome.

(b) An aircraft flying within such a zone for the purpose of observing the signals shall remain clear of cloud and at least 500 feet above the level of the aerodrome.

(2) The commander of an aircraft flying in such a zone or moving on such an aerodrome shall:

- (a) conform to the pattern of traffic formed by other aircraft, or keep clear of the airspace in which the pattern is formed;
- (b) make all turns to the left unless ground signals otherwise indicate; and
- (c) take off and land in the direction indicated by the ground signals or, if no such signals are displayed, into the wind, unless good aviation practice demands otherwise.

(3) (a) A flying machine or glider shall not land on a runway at such an aerodrome unless the runway is clear of other aircraft.

(b) Where take-offs and landings are not confined to a runway -

- (i) a flying machine or glider when landing shall leave clear on its left any aircraft which has already landed or is already landing or is about to take off; if such a flying machine or glider is obliged to turn, it shall turn to the left after the commander of the aircraft has satisfied himself that such action will not interfere with other traffic movements; and
- (ii) a flying machine about to take off shall take up position and manoeuvre in such a way as to leave clear on its left any aircraft which is already taking off or is about to take off.

(4) A flying machine after landing shall move clear of the landing area in use as soon as it is possible to do so.

### *Aerodromes having Air Traffic Control Units*

**35** (1) An aircraft shall not fly within a zone which the commander of the aircraft knows or ought reasonably to know to be the aerodrome traffic zone of an aerodrome where an air traffic control unit is for the time being notified as being on watch, except for the purpose of observing any signals at that aerodrome with a view to landing there, unless he has the permission of the appropriate air traffic control unit.

(2) The commander of an aircraft flying in the aerodrome traffic zone of an aerodrome where an air traffic control unit is for the time being notified as being on watch or moving on such an aerodrome shall -

- (a) cause a continuous watch to be maintained on the appropriate radio frequency notified for air traffic control communications at the aerodrome, or, if this is not possible, cause a watch to be kept for such instructions as may be issued by visual means;
- (b) not taxi on the apron or manoeuvring area or take off or land anywhere in the zone except with the permission of the air traffic control unit;
- (c) comply with the provisions of Rule 34(1)(b), (2), (3) and (4) of these Rules as if the aerodrome did not have an air traffic control unit, unless he has the permission of the air traffic control unit at the aerodrome, or has been instructed by that unit, to do otherwise.

(3) Without prejudice to the provisions of Rules 20 and 27 of these Rules, the commander of an aircraft shall, immediately upon arrival at, or prior to departure from, an aerodrome within Seychelles having an air traffic control unit, ensure that such unit is informed of the flight which he has just made or which he is about to undertake.

## SECTION VIII

### AERODROME SIGNALS AND MARKINGS; VISUAL AND

#### AURAL SIGNALS

#### *General*

**36** (1) Whenever any signal specified in this Section of these Rules is given or displayed, or whenever any marking so specified is displayed, by any person in an aircraft, or at an aerodrome, or at any other place which is being used by aircraft for landing or take-off, it shall, when given or displayed in Seychelles, have the meaning assigned to it in this Section.

(2) All dimensions specified in this Section of these Rules shall be subject to a tolerance of 10 per cent, plus or minus.



*Signals in the Signals area*

**37** (1) When any signal specified in the following paragraphs of this Rule is displayed it shall be placed in a signals area, which shall be a square visible in all directions bordered by a white strip 30 centimetres wide the internal sides measuring 12 metres.

(2) A white landing T, as illustrated in this paragraph,

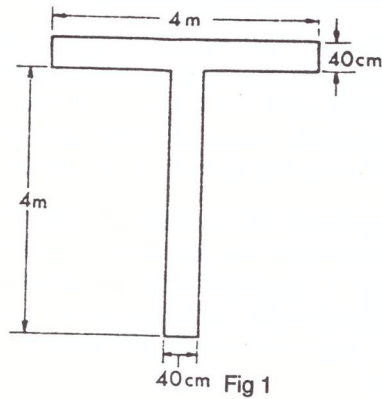

signifies that aeroplanes and gliders taking off or landing shall do so in a direction parallel with the shaft of the T and towards the cross arm, unless otherwise authorised by the appropriate air traffic control unit.

(3) A white disc 60 centimetres in diameter displayed alongside the cross arm of the T and in line with the shaft of the T, as illustrated in this paragraph.

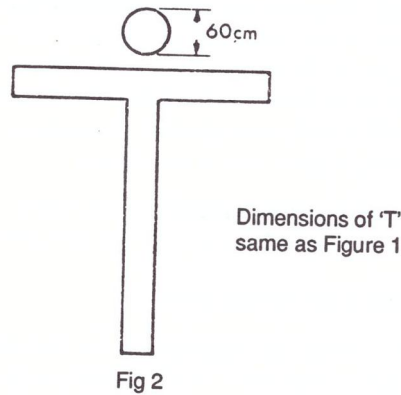

signifies that the direction of landing and take-off do not necessarily coincide.

(4) A white dumb-bell, as illustrated in this paragraph,

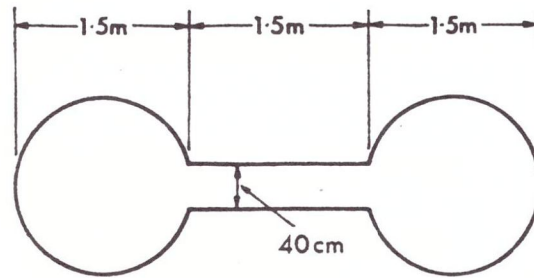

Fig 3

signifies that movements of aeroplanes and gliders on the ground shall be confined to paved, metalled or similar hard surfaces.

(5) A white dumb-bell as described in (4) above but with a black strip 60 centimetres wide across each disc at right angles to the shaft of the dumb-bell, as illustrated in this paragraph,

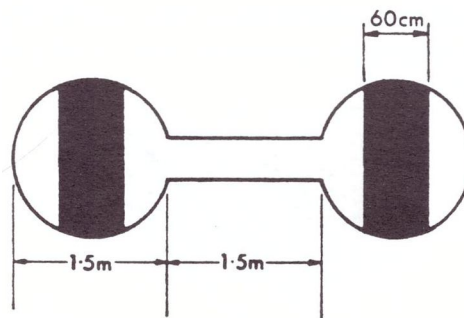

Fig 4

signifies that aeroplanes and gliders taking off or landing shall do so on a runway but that movement on the ground is not confined to paved, metalled or similar hard surfaces.

(6) A red and yellow striped arrow, as illustrated in this paragraph,

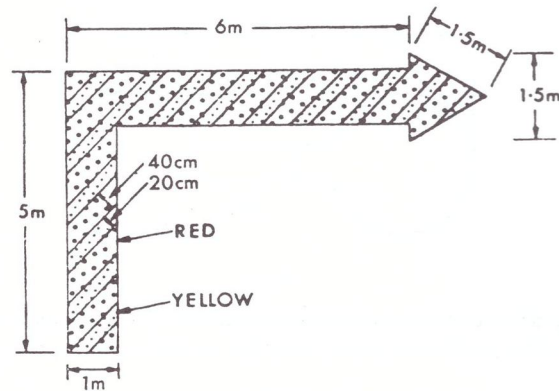

Fig 5

the shaft of which is at least one metre wide placed along the whole or not less than a total of 11 metres of two adjacent sides of the signals area and pointing in a clockwise direction signifies that a right-hand circuit is in force.

(7) A red panel 3 metres square with a yellow strip along one diagonal at least 50 centimetres wide, as illustrated in this paragraph,

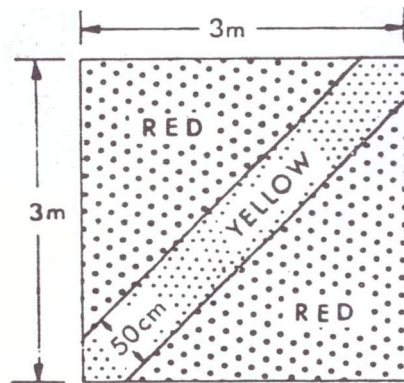
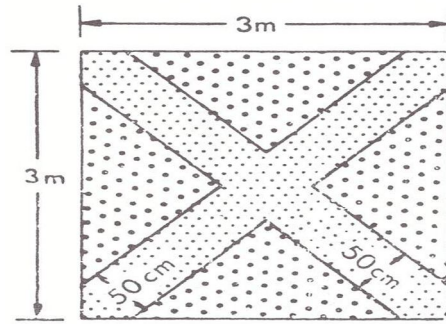

Fig 6

signifies that the state of the manoeuvring area is poor and pilots must exercise special care when landing.

(8) A red panel 3 metres square with a yellow strip, at least 50 centimetres wide, along each diagonal, as illustrated in this paragraph,



YELLOW STRIPES ON  
RED BACKGROUND

Fig 7

signifies that the aerodrome is unsafe for the movement of aircraft and that landing on the aerodrome is prohibited.

- (9) A white letter H, as illustrated in this paragraph,

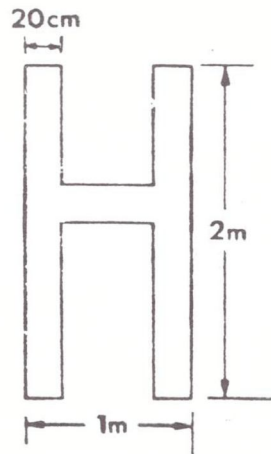

Fig 8

signifies that helicopters shall take off and land only within the area designated by the marking specified in Rule 39(5) of these Rules.

- (10) A red letter L displayed on the dumb-bell specified in paragraphs (4) and (5) of this Rule, as illustrated in this paragraph,

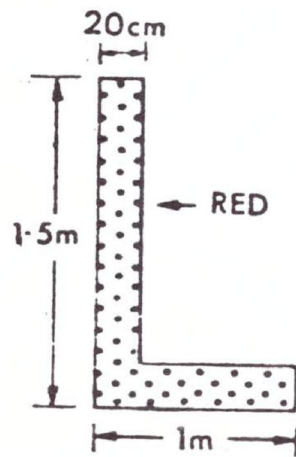

Fig 9

signifies that light aircraft are permitted to take off and land either on a runway or on the area designated by the marking specified in Rule 39(6) of these Rules.

(11) A white double cross, as illustrated in this paragraph,

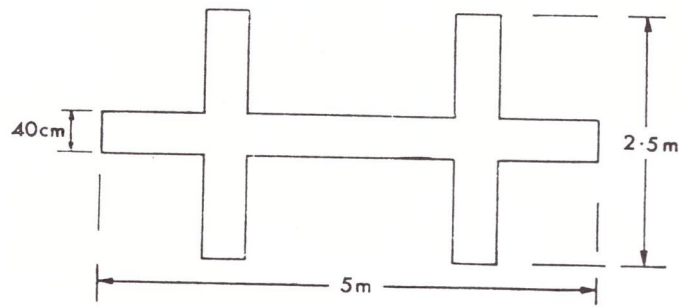

Fig 10

signifies that glider flying is in progress.

*Markings for Paved Runways and Taxiways*

**38** (1) Two or more white crosses, as illustrated in this paragraph,

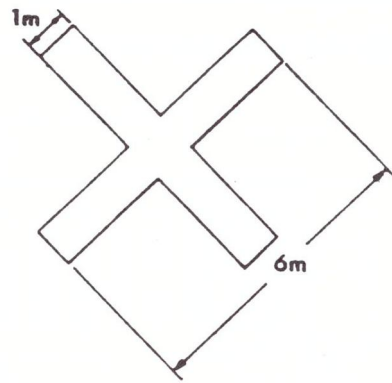

Fig 11

displayed on a runway or taxiway, with the arms of the crosses at an angle of 45° to the centre line of the runway, at intervals of not more than 300 metres signify that the section of the runway or taxiway marked by them is unfit for the movement of aircraft.

(2) A broken white line and a continuous line, as illustrated in this paragraph,

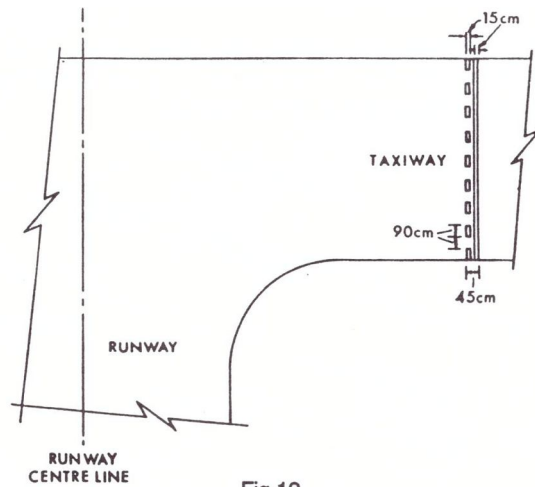

Fig 12

signify a holding position beyond which no part of an aircraft or vehicle shall project in the direction of the runway without permission from an air traffic control unit.

(3) Orange and white markers, as illustrated in this paragraph,

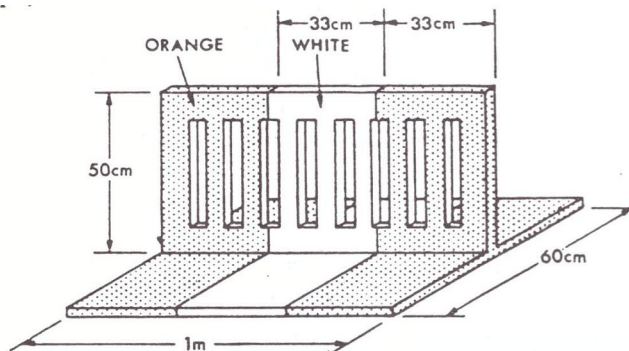

Fig 13

spaced not more than 15 metres apart, signify the boundary of that part of a paved runway, taxiway or apron which is unfit for the movement of aircraft.

*Markings on Unpaved Manoeuvring Areas*

**39** (1) Markers with orange and white stripes of an equal width of not less than 50 centimetres, with an orange stripe at each end, as illustrated in this paragraph,

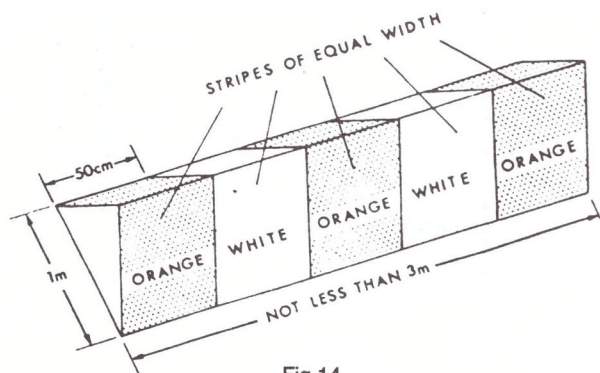

Fig 14

alternating with flags not less than 60 centimetres square showing equal orange and white triangular areas, indicate the

boundary of an area unfit for the movement of aircraft and one or more white crosses as specified in Rule 38(1) of these Rules indicate the said area. The distance between any two successive orange and white flags shall not exceed 90 metres.

(2) Striped markers, as specified in paragraph (1) of this Rule, spaced not more than 45 metres apart, indicate the boundary of an aerodrome.

(3) On structures, markers with orange and white vertical stripes, of an equal width of not less than 50 centimetres, with an orange stripe at each end, as illustrated in this paragraph,

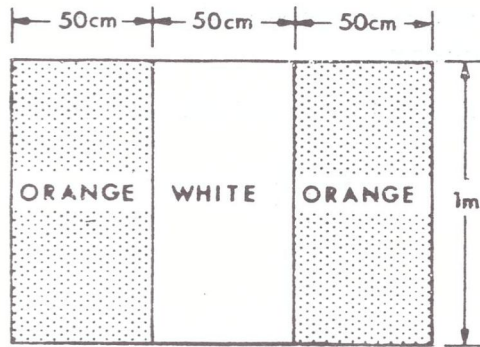

Fig 15

spaced not more than 45 metres apart, indicate the boundary of an aerodrome. The pattern of the marker shall be visible from inside and outside the aerodrome and the marker shall be affixed not more than 15 centimetres from the top of the structure.

(4) White flat rectangular markers 3 metres long and 1 metre wide at intervals not exceeding 90 metres, flush with the surface of the unpaved runway or stopway, as the case may be, indicate the boundary of an unpaved runway or of a stopway.

(5) A white letter H, as illustrated in this paragraph,

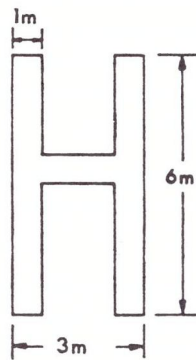

Fig 16

indicates an area which shall be used only for the taking off and landing of helicopters.

(6) A white letter L as illustrated in this paragraph,



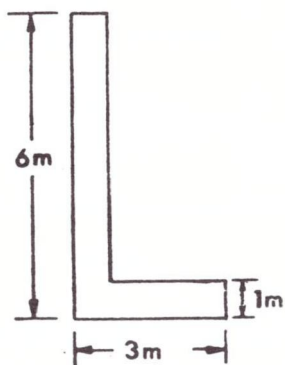

Fig 17

indicates a part of the manoeuvring area which shall be used only for the taking off and landing of light aircraft.

(7) A yellow cross with two arms 6 metres long by 1 metre wide at right angles, indicates that tow ropes and similar articles towed by aircraft shall only be dropped in the area in which the cross is placed.

(8) A white double cross as illustrated in this paragraph,

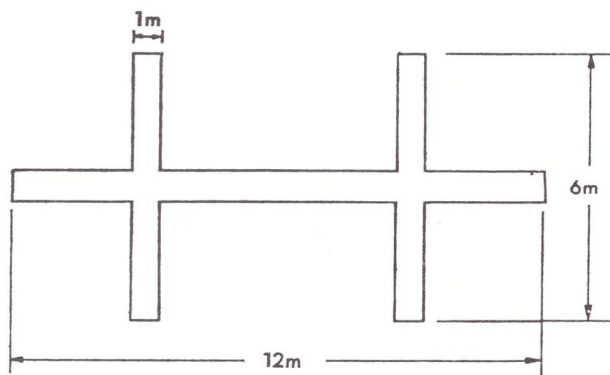

Fig 18

indicates an area which shall be used only for the taking off and landing of gliders.

(9) A white landing T as specified in Rule 37(2) of these Rules placed at the left hand side of the runway when viewed from the direction of landing indicates the runway to be used, and at an aerodrome with no runway it indicates the direction for take-off and landing.

*Signals Visible from the Ground*

**40** (1) A black ball 60 centimetres in diameter suspended from a mast signifies that the directions of take-off and landing are not necessarily the same.

(2) A checkered flag or board, 1.2 metres by 90 centimetres containing twelve equal squares, 4 horizontally and 3 vertically, coloured red and yellow alternately, signifies that aircraft may move on the manoeuvring area and apron only in accordance with the permission of the air traffic control unit at the aerodrome.

(3) Two red balls 60 centimetres in diameter, disposed vertically one above the other, 60 centimetres apart and suspended from a mast, signify that glider flying is in progress at the aerodrome.

(4) Black arabic numerals in two-figure groups and, where parallel runways are provided the letter or letters L (left) LCC (left centre), C (Centre), RC (right centre) and R (right), placed against a yellow background, indicate the direction for take-off or the runway in use.

(5) A black letter C against a yellow background, as illustrated in this paragraph,

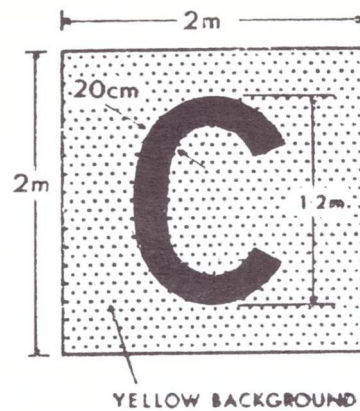

Fig 19

indicates the position at which a pilot can report to the air traffic control unit or to the person in charge of the aerodrome.

(6) A rectangular green flag of not less than 60 centimetres square flown from a mast indicates that a right hand circuit is in force.

#### *Lights and Pyrotechnic Signals for Control of Aerodrome Traffic*

**41.** Each signal described in the first column of Table A, when directed from an aerodrome to an aircraft or to a vehicle, or from an aircraft, shall have the meanings respectively appearing in the second, third and fourth columns of that Table opposite the description of the signals.

TABLE A  
MEANING OF LIGHTS AND PYROTHECHNIC SIGNALS

Characteristic and colour of light beam or pyrotechnic	From and aerodrome		From an aircraft in flight to aerodrome
	to an aircraft in flight	to an aircraft or vehicle on the aerodrome	
(a) Continuous red light	Give way to other aircraft and continue circling	Stop	<b>Immediate assistance is required</b>
(b) Red pyrotechnic light, or Red flare	Do not land; wait for permission	—	
(c) Red flashes	Do not land; aerodrome not available for landing	Move clear of landing area	—
(d) Green flashes	Return to aerodrome; wait for permission to land	To an aircraft: You may move on the manoeuvring area and apron; To a vehicle: You may move on the manoeuvring area	—
(e) Continuous green light	You may land	You may take off (not applicable to a vehicle)	—
(f) Continuous green light, or green glasses, or green pyrotechnic light	—	—	By night: May I land? By day: May I land in direction different from that indicated by landing T?
(g) White flashes	Land at this aerodrome after receiving continuous green light, and then, after receiving green flashes, proceed to the apron	Return to starting point on the aerodrome	I am compelled to land.
(h) White pyrotechnic lights Switching on and off the navigation lights Switching on and off the landing lights	—	—	I am compelled to land

*Marshalling Signals (from a marshaller to an aircraft)*

42. Each of the signals for the guidance of aircraft manoeuvring on or off the ground, described in the first column of Table B, paragraphs (a) to (y) shall, in Seychelles, have the meaning set fourth in the second column of that Table opposite the description of the signal. By day any such signals shall be given by hand or by circular bats and by night torches or illuminated wands.

TABLE B — MEANING OF MARSHALLING SIGNALS

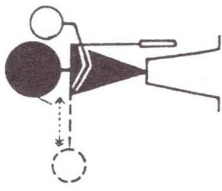
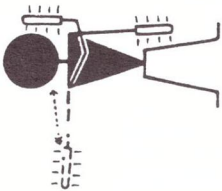
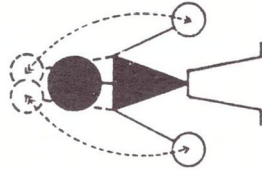
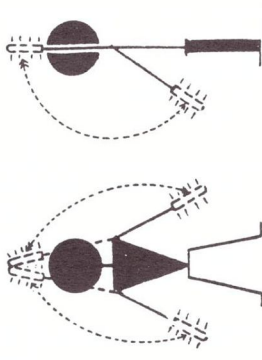
Description of Signal	Meaning of Signal	In Daylight	By night
(a) Right or left arm moved across body and extended to indicate the position of the other marshaller.	Proceed under guidance of another marshaller.		
(b) Arms repeatedly moved upward and backward, beckoning onward.	Move ahead.		

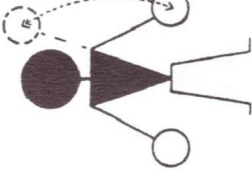
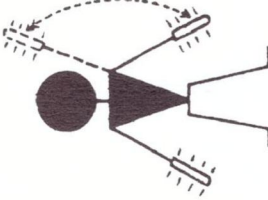
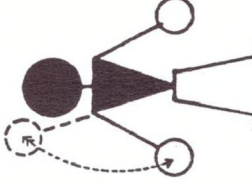
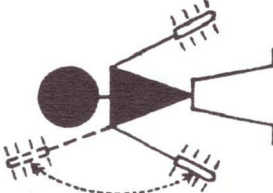
Description of Signal	Meaning of Signal	In Daylight	By night
<p>(c) Right arm down, left arm repeatedly moved upward and backward. The speed of arm movement indicates the rate of turn.</p>	<p>Open up starboard engine or turn to port.</p>		
<p>(d) Left arm down, the right arm repeatedly moved upward and backward. The speed of arm movement indicates the rate of turn.</p>	<p>Open up port engine or turn to starboard.</p>		

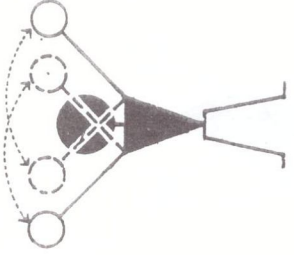
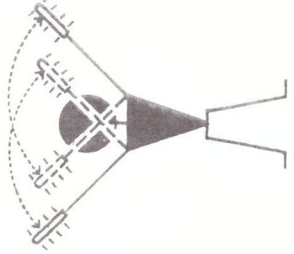
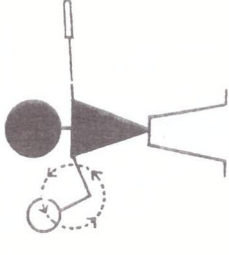
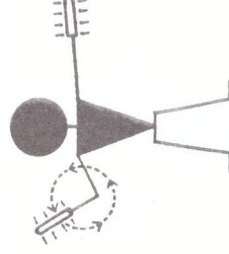
Description of Signal	Meaning of Signal	In Daylight	By night
<p>(e) Arms repeatedly crossed above the head. The speed of arm movement indicates the urgency of the stop</p>	<p>Stop</p>		
<p>(f) A circular motion of the right hand at head level, with the left arm pointing to the appropriate engine.</p>	<p>Start engines.</p>		

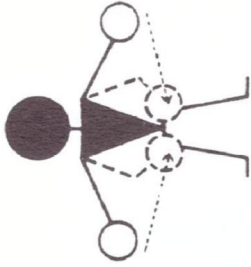
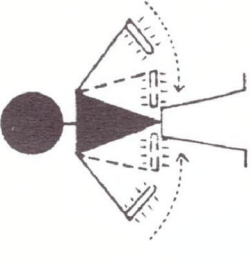
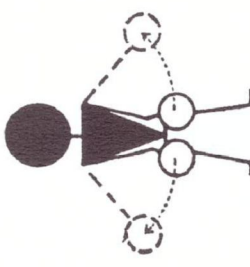
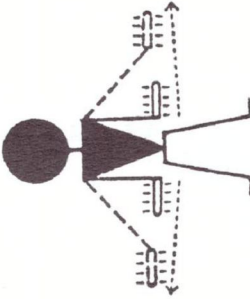

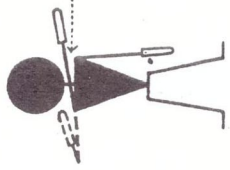
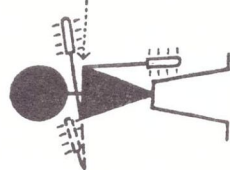
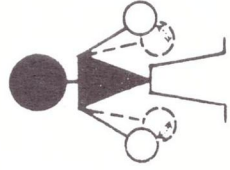
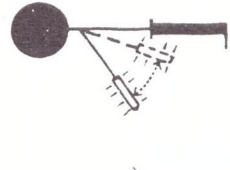
Description of Signal	Meaning of Signal	In Daylight	By night
<p>(g) Arms extended, the palms facing inwards, then swung from the extended position inwards.</p>	<p>Chocks inserted.</p>		
<p>(h) Arms down, the palms facing outwards, then swung outwards.</p>	<p>Chocks away.</p>		

Description of Signal	Meaning of Signal	In Daylight	By night
<p>(i) Either arm and hand placed level with the chest, then moved laterally with the palm downwards.</p>	<p>Cut engines.</p>		
<p>(j) Arms placed down, with palms towards the ground, then moved up and down several times.</p>	<p>Slow down.</p>		

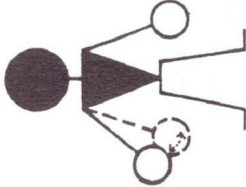
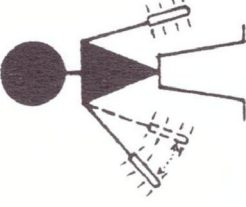
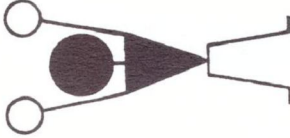
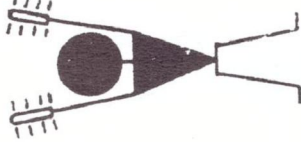

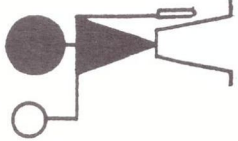
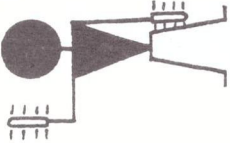
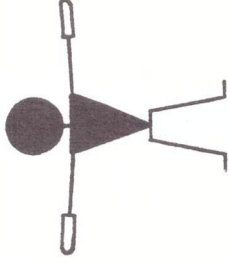
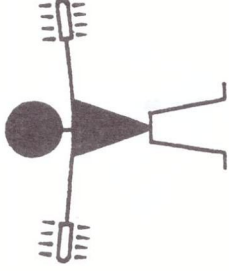

Description of Signal	Meaning of Signal	In Daylight	By night
<p>(k) Arms placed down, with the palms towards the ground, then either the right or left arm moved, up and down indicating that the motors on the left or right side, as the case may be, should be slowed down.</p>	<p>Slow down engines on indicated side.</p>		
<p>(l) Arms placed above head in a vertical position</p>	<p>This bay</p>		

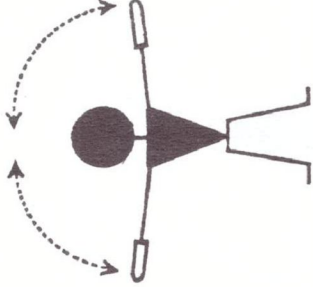
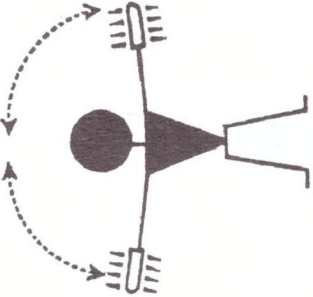
Description of Signal	Meaning of Signal	In Daylight	By night
(m) The right arm raised at the elbow, with the arm facing forward.	All clear: Marshaling finished.		
(n) Arms placed horizontally sideways.	Hover.		

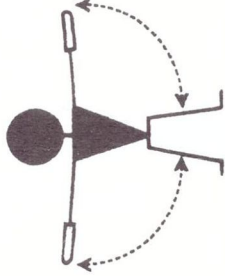
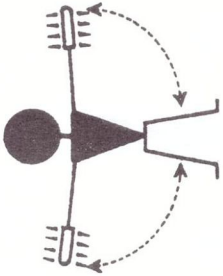
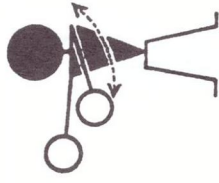
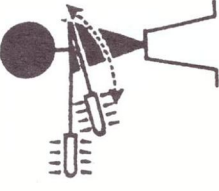
Description of Signal	Meaning of Signal	In Daylight	By night
(o) Arms placed down and crossed in front of the body.	Land.		
(p) Arms placed horizontally with the palms up beckoning upwards. The speed of arm movement indicates the rate of ascent.	Move upwards.		

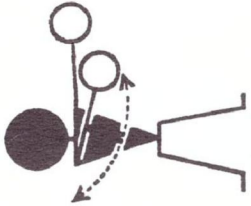
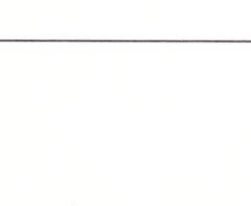
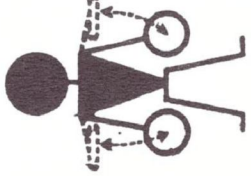
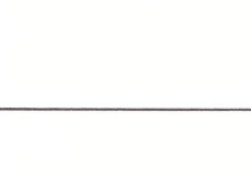
Description of Signal	Meaning of Signal	In Daylight	By night
<p>(q) Arms placed horizontally sideways with the palms towards the ground beckoning downwards. The speed of arm movement indicates the rate of descent.</p>	<p>Move downwards.</p>		
<p>(r) Either arm placed horizontally sideways, then the other arm moved in the front of the body to that side, in the direction of the movement, indicating that the helicopter should move horizontally to the left or right side, as the case may be; repeated several times.</p>	<p>Move horizontally.</p>		

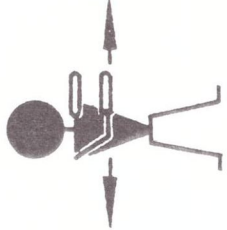
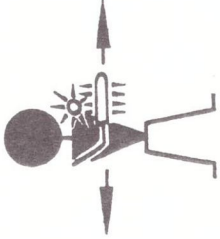
Description of Signal	Meaning of Signal	In Daylight	By night
(r) (Contd.)			
(s) Arms placed down, the palms facing forward, then repeatedly swept up and down to shoulder level.	Move back.		

Description of Signal	Meaning of Signal	In Daylight	By night
(t) Left arm extended horizontally forward, then right arm making a horizontal slicing movement below left arm.	Release load.		
(u) Raise arm, with first clenched, horizontally in front of body, then extend fingers.	Release brakes.		

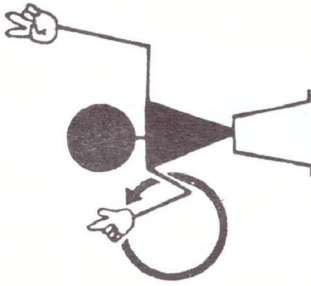
Description of Signal	Meaning of Signal	In Daylight	By night
<p>(v) Raise arm and hand, with fingers extended, horizontally in front of body, then clench fist.</p>	<p>Engage brakes.</p>		
<p>(w) Left hand overhead with the number of fingers extended, to indicate the number of engine to be started, and circular motion of right hand at head level.</p>	<p>Start Engine(s).</p>		

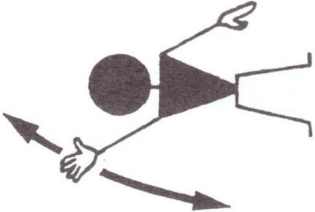
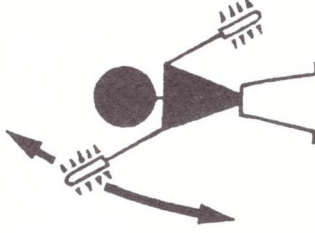
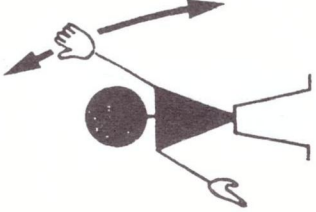
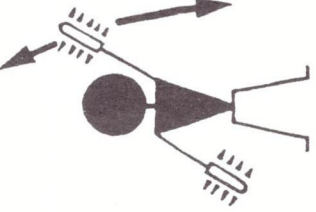
Description of Signal	Meaning of Signal	In Daylight	By night
(x) Point left arm down, move right arm down from overhead, vertical position to horizontal position, repeating right arm movement.	Back aircraft' tail to starboard.	 <p>A stick figure with its right arm raised overhead and its left arm pointing down and to the left. A curved arrow indicates the right arm moving down to a horizontal position.</p>	 <p>A stick figure with its right arm raised overhead and its left arm pointing down and to the left. Both arms have light sources at the hands. A curved arrow indicates the right arm moving down to a horizontal position.</p>
(y) Point right arm down, move left arm down from overhead, vertical position to horizontal position, repeating left arm movement.	Back aircraft's tail to port.	 <p>A stick figure with its left arm raised overhead and its right arm pointing down and to the left. A curved arrow indicates the left arm moving down to a horizontal position.</p>	 <p>A stick figure with its left arm raised overhead and its right arm pointing down and to the left. Both arms have light sources at the hands. A curved arrow indicates the left arm moving down to a horizontal position.</p>



Marshalling Signals (from a pilot of an aircraft to a marshaller)

**43.** The following signals made by a pilot in an aircraft to a marshaller on the ground shall respectively have the following meanings :-

Description of Signal	Meaning of Signal
(a) Raise arm and hand with fingers extended horizontally in front of face, then clench fist.	Brakes engaged.
(b) Raise arm with fist clenched horizontally in front of face, then extend fingers.	Brakes released.
(c) Arms extended palms facing outwards, move hands inwards to cross in front of face.	Insert chocks.
(d) Hands crossed in front of face, palms facing outwards, move arms outwards.	Remove chocks.
(e) Raise the number of fingers on one hand indicating the number of the engine to be started. For this purpose the aircraft engines shall be numbered in relation to the marshaller facing the aircraft, from his right to his left, for example, No 1 engine shall be the port outer engine, No 2 engine shall be the port inner engine, No. 3 engine shall be the starboard inner engine, and No. 4 engine shall be the starboard outer engine.	Ready to start engines.

*Distress, Urgency and Safety Signals*

**44** (1) The following signals, given either together or separately before the sending of a message, signify that an aircraft is threatened by grave and imminent danger and requests immediate assistance:

- (a) by radiotelephony:
  - the spoken word "MAYDAY";
- (b) visual signalling:

- (i) the signal SOS (...---...);
  - (ii) a succession of pyrotechnic lights fired at short intervals each showing a single red light;
  - (iii) a parachute flare showing a red light;
- (c) by sound signalling other than radiotelephony:
- (i) the signal SOS (...---...);
  - (ii) a continuous sounding with any sound apparatus.

(2) The following signals, given either together or separately, before the sending of a message, signify that the commander of the aircraft wishes to give notice of difficulties which compel it to land but that he does not require immediate assistance:

- (a) a succession of white pyrotechnic lights;
- (b) the repeated switching on and off of the aircraft landing lights;
- (c) the repeated switching on and off of its navigation lights, in such a manner as to be clearly distinguishable from the flashing navigation lights described in Rule 11 of these Rules.

(3) The following signals, given either together or separately, indicate that the commander of the aircraft has an urgent message to transmit concerning the safety of a ship, aircraft, vehicle or other property of a person on board or within sight of the aircraft from which the signal is given:

- (a) by radiotelephony:  
the spoken word "PAN";
- (b) by visual signalling:  
the signal XXX (-..---...-);
- (c) by sound signalling other than radiotelephony:  
the signal XXX (-..---...-);

*Warning Signals to Aircraft in Flight*

**45.** In Seychelles, the following signals shall respectively have the following meanings:

- (a) (i) by day - a series of projectiles discharged at intervals of ten seconds, each showing on bursting black or white smoke, or

- (ii) by night - a series of projectiles discharged at intervals of ten seconds, each showing on bursting white lights or stars, or an intermittent white luminous beam directed at the aircraft,

indicates that the aircraft to which the signal is directed is in the vicinity of such an area as is referred to in Article 64(1)(c) of this Order and is required to change its course;

- (b) by day or by night, a series of projectiles discharged at intervals of ten seconds, each showing on bursting green lights or stars indicates that the aircraft required to land at the nearest aerodrome in accordance with the provisions of Article 64 of this Order.

## SECTION IX

### AIR TRAFFIC CONTROL

#### *Provision of Air Traffic Control Services*

**46** (1) At every aerodrome (other than a Government aerodrome) which is provided with means of two-way radio communication with aircraft and is either situated in a control zone or is an aerodrome in respect of which the Minister has given a direction to the proprietor or person in charge of the aerodrome requiring air traffic control service to be provided there, the person in charge of the aerodrome shall cause air traffic control service to be provided at all times when the aerodrome is open for the take-off and landing of aircraft.

(2) At every aerodrome (other than a Government aerodrome) which is provided with means of two-way radio communication with aircraft and with equipment for providing holding aid, let-down aid or approach aid by radio or radar the person in charge of the aerodrome shall inform the Minister in advance of any period during which any of the said equipment will be in operation for the purpose of providing holding aid, let-down aid or approach aid and, without prejudice to paragraph (1) of this Rule, cause air traffic control service to be provided at all times when the said equipment is notified as being in operation for any of those purposes.

## SCHEDULE 15

Articles 9(4), 10(3), 11(2) and

(5), 28(4), 29(1), 73 and 79

### AIR NAVIGATION (GENERAL) REGULATIONS

#### *Load Sheets*

**1** (1) Every load sheet required by Article 28(4) shall contain the following particulars:

- (a) the nationality mark of the aircraft to which the load sheet relates, and the registration mark assigned to that aircraft by the Minister;
- (b) particulars of the flight to which the load sheet relates;
- (c) the total weight of the aircraft as loaded for that flight;
- (d) the weights of the several items from which the total weight of the aircraft, as so loaded, has been calculated including in particular the weight of the aircraft prepared for service and the respective total weights of the crew (unless included in the weight of the aircraft prepared for service), passengers, baggage and cargo intended to be carried on the flight;
- (e) the manner in which the load is distributed and the resulting position of the centre of gravity of the aircraft which may be given approximately if and to the extent that the relevant certificate of airworthiness so permits,

and shall include at the foot or end of the load sheet a certificate, signed by the person referred to in Article 28(1) of this Order as responsible for the loading of the aircraft, that the aircraft has been loaded in accordance with the written instructions furnished to him by the operator of the aircraft pursuant to the said Article 28.

(2) For the purpose of calculating the total weight of the aircraft the respective total weights of the passengers and crew entered in the load sheet shall be computed from the actual weight of each person and for that purpose each person shall be separately weighed:

Provided that, in the case of an aircraft of which the maximum total weight authorised exceeds 5,700 kg. or which has a total seating capacity of 12 or more persons, the total weights of the passengers and crew may, subject to the provisions of paragraph (4) of this Regulation, be calculated at not less than the weights shown in Table 1 and the load sheet shall bear a notation to that effect:

Table 1

Males over 12 years of age	75 kg.
Females over 12 years of age	65 kg.
Children aged 2 years or more, but not over 12 years of age	39 kg.
Infants under 2 years of age	8 kg.

(3) (a) For the purpose of calculating the total weight of the aircraft the respective total weights of the baggage and cargo entered in the load sheet shall be computed from the actual weight of each piece of baggage, cargo or cargo container and for that purpose each piece or container shall be separately weighed:

Provided that, in the case of an aeroplane of which the maximum total weight authorised exceeds 5,700 kg. or which has a total seating capacity of 12 or more persons, the total weights of the baggage may, subject to the provisions of paragraph (4) of this Regulation, be calculated at not less than the weights shown in Table 2 and the load sheet shall bear a notation to that effect:

Table 2

1	2	3	
Journey made by the aeroplane	Cabin baggage per passenger*	Hold baggage per piece	
		Scheduled Journey	Holiday Journey
Domestic	3 kg.	10 kg.	13 kg.
European	3 kg.	12 kg.	13 kg.
Intercontinental	3 kg.	14 kg.	16 kg.

\*Not infants under 2 years of age.

- (b) If Table 2 has been used, subject to the provisions of paragraph (4) for determining the weight of hold baggage, it shall also be used, subject as aforesaid, for determining the weight of the cabin baggage.
- (c) For the purposes of this Regulation:
  - (i) A journey made by an aeroplane shall be treated as domestic if it is confined within such an area as may be prescribed;
  - (ii) A journey made by an aeroplane, not being a domestic journey, shall be treated as European if it is confined within an area joining successively the following points:

66°30'N 30°00'W

66°30'N 39°00'E

30°00'N 39°00'E

30°00'N 11°00'W

24°00'N 11°00'W

24°00'N 30°00'W

66°30'N 30°00'W.

- (iii) A journey made by an aeroplane shall be treated as intercontinental if it is neither domestic nor European.
- (iv) A journey made by an aeroplane shall be treated as a holiday journey and not as a Scheduled journey if it is made for the carriage of passengers each of whom is carried pursuant to an agreement which provides for carriage by air to a place outside Seychelles, and back from that place or from another place to Seychelles (whether or not on the same aeroplane) and for accommodation at a place outside Seychelles.

(4) (a) If it appears to the person supervising the loading of the aircraft that any passenger or baggage to be carried exceeds the weights set out in Table 1 or Table 2 of this Regulation he shall, if he considers it necessary in the interests of the safety of the aircraft, or if the Minister has so directed in the particular case, require any such person or baggage to be weighed for the purpose of the entry to be made in the load sheet.

(b) If any person or baggage has been weighed pursuant to sub-paragraph (a) of this paragraph, the weights entered in the load sheet shall take account of the actual weight of that person or baggage, or of the weight determined in accordance with the respective proviso to paragraph (2) or (3), whichever weight shall be the greater.

*Weight and Performance: General provisions*

**2** (1) The assessment of the ability of an aeroplane to comply with the requirements of Regulations 3 to 8 inclusive (relating to weight and performance) shall be based on the specified information as to its performance:

Provided that, in the case of an aeroplane in respect of which there is in force under this Order a certificate of airworthiness which does not include a performance group classification, the assessment may be based on the best information available to the commander of the aircraft, in so far as the relevant information is not specified.

(2) In assessing the ability of an aeroplane to comply with condition (7) in the Annex hereto, conditions (4) and (5) of Regulation 4, and conditions (2)(i)(b) and (2)(ii) of Regulation 8, account may be taken of any reduction of the weight of the aeroplane which may be achieved after the failure of a power unit by such jettisoning of fuel as is feasible and prudent in the circumstances of the flight and in accordance with the flight manual included in the certificate of airworthiness relating to the aircraft.

(3) In Regulations 2 to 8 inclusive, and in the Annex hereto, unless the context otherwise requires:

"specified" in relation to an aircraft means specified in, or ascertainable by reference to-

- (a) the certificate of airworthiness in force under this Order in respect of that aircraft; or
- (b) the flight manual or performance schedule included in that certificate, or other document, whatever its title, incorporated by reference in that certificate;

"the emergency distance available" means the distance from the point on the surface of the aerodrome at which the aeroplane can commence its take-off run to the nearest point in the direction of take-off at which the aeroplane cannot roll over the surface of the aerodrome and be brought to rest in an emergency without risk of accident;

"the landing distance available" means the distance from the point on the surface of the aerodrome above which the aeroplane can commence its landing, having regard to the obstructions in its approach path, to the nearest point in the direction of landing at which the surface of the aerodrome is incapable of bearing the weight of the aeroplane under normal operating conditions or at which there is an obstacle capable of affecting the safety of the aeroplane;

"the take-off distance available" means either the distance from the point on the surface of the aerodrome at which the aeroplane can commence its take-off run to the nearest obstacle in the direction of take-off projecting above the surface of the aerodrome and capable of affecting the safety of the aeroplane or one and one half times the take-off run available, whichever is the less;

"the take-off run available" means the distance from the point on the surface of the aerodrome at which the aeroplane can commence its take-off run to the nearest point in the direction of take-off at which the surface of the aerodrome is incapable of bearing the weight of the aeroplane under normal operating conditions.

(4) For the purposes of Regulations 2 to 8 inclusive, and of the Annex hereto:

- (a) the weight of the aeroplane at the commencement of the take-off run shall be taken to be its gross weight including everything and everyone carried on or on it at the commencement of the take-off run;
- (b) the landing weight of the aeroplane shall be taken to be the weight of the aeroplane at the estimated time of landing allowing for the weight of the fuel and oil expected to be used on the flight to the aerodrome

at which it is intended to land or alternate aerodrome, as the case may be;

- (c) where any distance referred to in paragraph (3) of this Regulation has been declared in respect of any aerodrome by the authority responsible for regulating air navigation over the territory of the Contracting State in which the aerodrome is situated, and, in the case of an aerodrome in Seychelles, notified, that distance shall be deemed to be the relevant distance.

(5) Nothing in Regulations 2 to 8 inclusive shall apply to any aircraft flying solely for the purpose of training persons to perform duties in aircraft.

*Weight and Performance of Public Transport Aeroplanes having no Performance Group Classification in their Certificates of Airworthiness*

**3.** With reference to Article 29(1) an aeroplane registered in Seychelles in respect of which there is in force under this Order a certificate of airworthiness which does not include a performance group classification shall not fly for the purpose of public transport unless the weight of the aeroplane at the commencement of the take-off run is such that such of the conditions in the annex hereto as apply to that aircraft are satisfied.

*Weight and performance of Public Transport Airplanes Classified as Aeroplanes of Performance Group A in their Certificate of Airworthiness*

**4.** With reference to Article 29(1) on aeroplane registered in Seychelles in respect of which there is in force under this Order a certificate of airworthiness in which the aeroplane is designated as being of performance group A shall not fly for the purpose of public transport unless the weight of the aeroplane at the commencement of the take-off run is such that the following conditions are satisfied.

- (1) That weight does not exceed the maximum take-off weight for altitude and temperature specified for the altitude and the air temperature at the aerodrome at which the take-off is to be made.
- (2) The take-off run, take-off distance and the emergency distance respectively required for take-off, specified as being appropriate to-
  - (a) the weight of the aeroplane at the commencement of the take-off run;
  - (b) the altitude at the aerodrome;
  - (c) the air temperature at the aerodrome;
  - (d) the condition of the surface of the runway from which the take-off will be made;



- (e) the slope of the surface of the aerodrome in the direction of take-off over the take-off run available, the take-off distance available and the emergency distance available, respectively; and
- (f) not more than 50 per cent of the reported wind component opposite to the direction of take-off or not less than 150 per cent of the reported wind component in the direction of take-off,

do not exceed the take-off run, the take-off distance and the emergency distance available, respectively, at the aerodrome at which the take-off is to be made; in ascertaining the emergency distance required, the point at which the pilot is assumed to decide to discontinue the take-off shall not be nearer to the start of the take-off than the point at which, in ascertaining the take-off run required and the take-off distance required, he is assumed to decide to continue the take-off, in the event of power unit failure.

- (3) (a) The net take-off flight path with one power unit inoperative, specified as being appropriate to:
  - (i) the weight of the aeroplane at the commencement of the take-off run;
  - (ii) the altitude at the aerodrome;
  - (iii) the air temperature at the aerodrome; and
  - (iv) not more than 40 per cent of the reported wind component opposite to the direction of take-off or not less than 150 per cent of the reported wind component in the direction of take-off,

and plotted from a point 35 feet or 50 feet, as appropriate, above the end of the take-off distance required at the aerodrome at which the take-off is to be made to a height of 1,500 feet above the aerodrome, shows that the aeroplane will clear any obstacle in its path by a vertical interval of at least 35 feet; and if it is intended that the aeroplane shall change its direction of flight by more than 15 degrees the vertical interval shall not be less than 50 feet during the change of direction.

- (b) For the purpose of sub-paragraph (a) hereof an obstacle shall be deemed to be in the path of the aeroplane if the distance from the obstacle to the nearest point on the ground below the intended line of flight of the aeroplane does not exceed:
  - (i) a distance of 60 metres plus half the wing span of the aeroplane plus one eighth of the distance from such point to the end of the take-off distance available measured along the intended line of flight of the aeroplane; or
  - (ii) 1,500 metres,

whichever is the less.

- (c) In assessing the ability of the aeroplane to satisfy this condition, it shall not be assumed to make a change of direction of a radius less than the specified radius of steady turn.
- (4) The aeroplane will, in the meteorological conditions expected for the flight, in the event of any one power unit becoming inoperative at any point on its route or on any planned diversion therefrom and with the other power unit or units operating within the maximum continuous power conditions specified, be capable of continuing the flight, clearing by a vertical interval of at least 2,000 feet obstacles within 10 nautical miles either side of the intended track, to an aerodrome at which it can comply with condition (7) in this Regulation relating to an alternate aerodrome, and on arrival over such aerodrome the gradient of the specified net flight path with one power unit inoperative shall not be less than zero at 1,500 feet above the aerodrome; and in assessing the ability of the aeroplane to satisfy this condition it shall not be assumed to be capable of flying at an altitude exceeding the specified maximum permissible altitude for power unit restarting:

Provided that where the operator of the aeroplane is satisfied, taking into account the navigation aids which can be made use of by the aeroplane on the route, that the commander of the aeroplane will be able to maintain his intended track on that route within a margin of 5 nautical miles, the foregoing provisions of this paragraph shall have effect as if 5 nautical miles, were substituted for 10 nautical miles.

- (5) The aeroplane will, in the meteorological conditions expected for the flight, in the event of any two power units becoming inoperative at any point along the route or on any planned diversion therefrom more than 90 minutes flying time in still air at the all power units operating economical cruising speed from the nearest aerodrome at which it can comply with condition (7) in this Regulation, relating to an alternate aerodrome, be capable of continuing the flight with all other power units operating within the specified maximum continuous power conditions, clearing by a vertical interval of at least 2,000 feet obstacles within 10 nautical miles either side of the intended track to such an aerodrome, and on arrival over such aerodrome the gradient of the specified net flight path with two power units inoperative shall not be less than zero at 1,500 feet above the aerodrome; and in assessing the ability of the aeroplane to satisfy this condition it shall not be assumed to be capable of flying at an altitude exceeding the maximum permissible altitude for power unit restarting;

Provided that where the operator of the aeroplane is satisfied, taking into account the navigation aids which can be made use of by the aeroplane on the route, that the commander of the aeroplane will be able to maintain his intended track on that route within a margin of 5 nautical miles, the foregoing provisions of this paragraph shall have effect as of 5 nautical miles were substituted for 10 nautical miles.

- (6) The landing weight of the aeroplane will not exceed the maximum landing weight specified for the altitude and the expected air temperature for the estimated time of landing at the aerodrome at which it is intended to land and at any alternate aerodrome.
- (7) (a) The landing distances required, respectively specified as being appropriate to aerodrome of destination and alternate aerodromes, do not exceed at the aerodromes at which it is intended to land or at any alternate aerodrome, as the case may be, the landing distance available on:
  - (i) the most suitable runway for a landing in still air conditions; and
  - (ii) the runway that may be required for landing because of the forecast wind conditions: Provided that if an alternate aerodrome is designated in the flight plan, the specified landing distance required may be that appropriate to an alternate aerodrome when assessing the ability of the aeroplane to satisfy this condition at the aerodrome of destination.
- (b) For the purposes of sub-paragraph (a) hereof the landing distance required shall be that specified as being appropriate to:
  - (i) the landing weight;
  - (ii) the altitude at the aerodrome;
  - (iii) the temperature in the specified international standard atmosphere appropriate to the altitude at the aerodrome;
  - (iv) (aa) a level surface in the case of runways usable in both directions; (bb) the average slope of the runway in the case of runways usable in only one direction; and
  - (v) (aa) still air conditions in the case of the most suitable runway for a landing in still air conditions;
    - (bb) not more than 50 per cent of the forecast wind component opposite to the direction of landing or not less than 150 per cent of the forecast wind component in the direction of landing in the case of the runway that may be required for landing because of the forecast wind conditions

*Weight and Performance of Public Transport Aeroplanes classified as Aeroplanes of Performance Group C in their Certificate of Airworthiness*

5. With reference to Article 29(1) an aeroplane registered in Seychelles in respect of which there is in force under this Order a certificate of airworthiness in which the

aeroplane is designated as being of performance group C shall not fly for the purpose of public transport unless the weight of the aeroplane at the commencement of the take-off is such that the following conditions are satisfied:

- (1) That weight does not exceed the maximum take-off weight specified for the altitude and the air temperature at the aerodrome at which the take-off is to be made.
- (2) The take-off run required and the take-off distance required, specified as being appropriate to:-
  - (a) the weight of the aeroplane at the commencement of the take-off run;
  - (b) the altitude of the aerodrome;
  - (c) the air temperature at the aerodrome;
  - (d) the average slope of the surface of the aerodrome in the direction of take-off over the emergency distance available; and
  - (e) not more than 50 per cent of the reported wind component opposite to the direction of take-off or not less than 150 per cent of the reported wind component in the direction of take-off,

do not exceed the take-off run available and the emergency distance available, respectively, at the aerodrome at which the take-off is to be made.

- (3) (a) Subject to condition (4) of this Regulation, the net take-off flight path with all power units operating specified as being appropriate to:-
  - (i) the weight of the aeroplane at the commencement of the take-off run;
  - (ii) the altitude of the aerodrome;
  - (iii) the air temperature at the aerodrome;
  - (iv) not more than 50 per cent of the reported wind component opposite to the direction of take-off or not less than 150 per cent of the reported wind component in the direction of take-off;

and plotted from a point 50 feet above the end of the take-off distance required at the aerodrome at which the take-off is to be made to a height of 1,500 feet above the aerodrome shows that the aeroplane will clear any obstacle in its path by a vertical interval of not less than 35 feet; and if it is intended that the aeroplane shall change its direction of flight by more than 15° before reaching the vertical 1500 feet interval shall be not less than 50 feet while the aircraft is changing direction.

- (b) for the purpose of sub-paragraph (a) hereof an obstacle shall be deemed to be in the path of the aeroplane if the distance from the obstacle to the nearest point on the ground below the intended line of flight of the aeroplane does not exceed 75 metres.
  - (c) In assessing the ability of the aeroplane to satisfy this condition, it shall not be assumed to make a change of direction of a radius less than the specified radius of steady turn.
- (4) (a) In the case of an aeroplane which is intended to be flown for any period before reaching a height of 1,500 feet above the aerodrome from which the take-off is to be made in conditions which will not ensure that any obstacles can be located by means of visual observation, the net take-off flight path with one power unit inoperative specified as being appropriate to the factors contained in sub- paragraphs (i) to (iv) of condition 3(a) in this Regulation, and plotted from the point on the net take-off flight path with all power units operating specified as being appropriate to those factors at which in the meteorological conditions expected for the flight the loss of visual reference would occur, shows that the aeroplane will clear by a vertical interval of not less than 35 feet any obstacle in its path; and if it is intended that the aeroplane shall change its direction of flight by more than 15° the vertical interval shall not be less than 50 feet during the change of direction.
- (b) for the purpose of sub-paragraph (a) hereof an obstacle shall be deemed to be in the path of the aerodrome if the distance from the obstacle to the nearest point on the ground below the intended line of flight of the aeroplane does not exceed:
    - (i) 75 metres plus one eighth of the distance from such point to the end of the emergency distance available measured along the intended line of flight of the aeroplane; or
    - (ii) 1,500 metres,

whichever is the less.

- (c) In assessing the ability of the aeroplane to satisfy this condition it shall not be assumed to make a change of direction of a radius less than the specified radius of steady turn.
- (5) The aeroplane at any time after it reaches a height of 1,500 feet above the aerodrome from which the take-off is made will, in the meteorological conditions expected for the flight, in the event of any one power unit becoming inoperative at any point on its route or on any planned diversion therefrom, and with the other power unit or power units operating within the

specified maximum continuous power condition, be capable of continuing the flight at altitudes not less than the relevant minimum altitude for safe flight stated in, or calculated from the information contained in, the operations manual relating to the aeroplane to a point 1,500 feet above an aerodrome at which a safe landing can be made and after arrival at that point be capable of maintaining that height:

Provided that in assessing the ability of the aeroplane to satisfy this condition it shall not be assumed to be capable of flying at any point on its route at an altitude exceeding the performance ceiling, with all power units operating, specified as being appropriate to its estimated weight at that point.

- (6) The landing weight of the aeroplane will not exceed the maximum landing weight specified for the altitude and the expected air temperature for the estimated time of landing at the aerodrome at which it is intended to land and at any alternate aerodrome.
- (7) Subject to condition (8) of this Regulation, the distance required by the aeroplane to land from a height of 50 feet otherwise than in accordance with specified data for short field landing does not, at the aerodrome at which it is intended to land and at any alternate aerodrome, exceed 70 per cent of the landing distance available on the most suitable runway for a landing in still air conditions, and on the runway that may be required for landing because of the forecast wind conditions; and for the purposes of this condition the distance required to land from a height of 50 feet shall be taken to be that specified as being appropriate to:
  - (a) the landing weight;
  - (b) the altitude at the aerodrome;
  - (c) the temperature in the specified international standard atmosphere appropriate to the altitude at the aerodrome;
  - (d) (i) a level surface in the case of runways usable in both directions;  
(ii) the average slope of the runway in the case of runways usable in one direction; and
  - (e) (i) still air conditions in the case of the most suitable runway for landing in still air conditions;  
(ii) not more than 50 per cent of the forecast wind component opposite to the direction of landing or not less than 150 per cent of the forecast wind component in the direction of landing in the case of the runway that may be required for landing because of the forecast wind conditions.

- (8) As an alternative to condition (7) of this Regulation, the distance required by the aeroplane, with all power units operating and with one power unit inoperative, to land in accordance with specified data for short field landing, does not at the aerodrome of intended destination and at any alternate aerodrome exceed the landing distance available on the most suitable runway for landing in still air conditions and on the runway that may be required for landing because of the forecast wind conditions; and for the purpose of this condition the distance required to land from the appropriate heights shall be taken to be that specified as being appropriate to the factors set forth in sub-paragraph (a) to (e) of condition (7) of this Regulation and the appropriate height shall be:
- (a) for a landing with all power units operating: any height between 30 and 50 feet in Seychelles, and 50 feet elsewhere; and
  - (b) for a landing with one power unit inoperative: 50 feet in Seychelles and elsewhere:

Provided that -

- (i) if the specified distance required to land with one power unit inoperative from a height of 50 feet at the aerodrome of intended destination exceeds the landing distance available, it shall be sufficient compliance with sub-paragraph (b) of this condition if an alternate aerodrome which has available the specified landing distance required to land with one power unit inoperative from such a height, is designated in the flight plan;
- (ii) the distance required by the aeroplane to land shall be determined in accordance with condition (7) and not in accordance with this condition if it is intended to land at night, or when the cloud ceiling or ground visibility forecast for the estimated time of landing at the aerodrome of intended destination and at any alternate aerodrome at which it is intended to land in accordance with specified data for short field landing with all power units operating, are less than 500 feet and one nautical mile respectively.

*Weight and Performance of Public Transport Aeroplanes classified as Aeroplanes of Performance Group D in their Certificate of Airworthiness*

**6.** With reference to Article 29(1) an aeroplane registered in Seychelles in respect of which there is in force under this Order a certificate of airworthiness in which the aeroplane is designated as being of performance group D shall not fly for the purpose of public transport at night or when the cloud ceiling or visibility prevailing at the aerodrome of departure and forecast for the estimated time of landing at the aerodrome at which it is intended to land and at any alternate aerodrome are less than 1,000 feet and one nautical mile respectively and shall not fly for the purpose of public transport at any other time unless the weight of the aeroplane at the commencement of the take-off run is such that the following conditions are satisfied:

- (1) That weight does not exceed the maximum take-off weight specified for the altitude and air temperature at the aerodrome at which the take-off is to be made.
- (2) The take-off run required and the take-off distance required specified as, being appropriate to -
  - (a) the weight of the aeroplane at the commencement of the take-off run;
  - (b) the altitude of the aerodrome;
  - (c) the air temperature at the aerodrome;
  - (d) the average slope of the surface of the aerodrome in the direction of take-off over the emergency distance available; and
  - (e) not more than 50 per cent of the reported wind component opposite to the direction of take-off or not less than 150 per cent of the reported wind component in the direction of take-off,

do not exceed the take-off run available and the emergency distance available, respectively, at the aerodrome at which the take-off is to be made.

- (3) (a) The net take-off flight path with all power units operating, specified as being appropriate to -
  - (i) the weight of the aeroplane at the commencement of the take-off run;
  - (ii) the altitude at the aerodrome;
  - (iii) the air temperature at the aerodrome; and
  - (iv) not more than 50 per cent of the reported wind component opposite to the direction of take-off or not less than 150 per cent of the reported wind component in the direction of take-off;

and plotted from a point 50 feet above the end of the take-off distance required at the aerodrome at which the take-off is to be made to the point at which the aeroplane reaches a height of 1,000 feet above the aerodrome shows that the aeroplane will clear any obstacle in its path by a vertical interval of not less than 35 feet, except that if it is intended that the aeroplane shall change its direction of flight by more than 15° before reaching 1,000 feet the vertical interval shall be not less than 50 feet while the aircraft is changing direction.

- (b) For the purpose of sub-paragraph (a) hereof an obstacle shall be deemed to be in the path of the aeroplane if the distance from the



obstacle to the nearest point on the ground below the intended line of flight of the aeroplane does not exceed 75 metres.

- (c) In assessing the ability of the aeroplane to satisfy this condition it shall not be assumed to make a change of direction of a radius less than the specified radius of steady turn.
- (4) The aeroplane, at any time after it reaches a height of 1,000 feet above the aerodrome from which take-off is to be made, will, in the meteorological conditions expected for the flight, in the event of any one power unit becoming inoperative at any point on its route or on any planned diversion therefrom, and with the other power unit or power units, if any, operating within the maximum specified continuous power conditions, be capable of continuing the flight at altitudes not less than the relevant minimum altitudes for safe flight stated in, or calculated from the information contained in, the operations manual relating to the aeroplane to a point 1,000 feet above a place at which a safe landing can be made:

Provided that in assessing the ability of the aeroplane to satisfy this condition it shall not be assumed to be capable of flying at any point on its route at an altitude exceeding the performance ceiling with all power units operating specified as being appropriate to its estimated weight at that point.

- (5) The landing weight of the aeroplane will not exceed the maximum landing weight specified for the altitude and the expected air temperature for the estimated time of landing at the aerodrome at which it is intended to land and at any alternate aerodrome.
- (6) The distance required by the aeroplane to land from a height of 50 feet does not, at the aerodrome at which it is intended to land and at any alternate aerodrome, exceed 70 per cent of the landing distance available on the most suitable runway for a landing in still air conditions, and on the landing because of the forecast wind conditions; and for the purposes of runway that may be required for this condition the distance required to land from a height of 50 feet shall be taken to be that specified as being appropriate to:-
  - (a) the landing weight;
  - (b) the altitude at the aerodrome;
  - (c) the temperature in the specified international standard atmosphere appropriate to the altitude at the aerodrome;
  - (d) (i) a level surface in the case of runways usable in both direction;
  - (ii) the average slope of the runway in the case of runways usable in only one direction;

- (e) (i) still air condition in the case of the most suitable runway for a landing in still air conditions;
- (ii) not more than 50 per cent of the forecast wind component opposite to the direction of landing or not less than 150 per cent of the forecast wind component in the direction of landing in the case of the runway that may be required for landing because of the forecast wind conditions.

*Weight and Performance of Public Transport Aeroplanes classified as Aeroplanes of Performance Group E in their Certificates of Airworthiness*

7 (1) With reference to Article 29(1) an aeroplane registered in Seychelles in respect of which there is in force under this Order a certificate of airworthiness in which the aeroplane is designated as being of performance group E shall not fly for the purpose of public transport unless the weight of the aeroplane at the commencement of the take-off run is such that the following conditions are satisfied:

- (a) That weight for the altitude and the air temperature at the aerodrome at which the take-off is to be made does not exceed the maximum take-off weight specified as being appropriate to:
  - (i) the weight at which the aeroplane is capable in the en route configuration and with all power units operating within the specified maximum continuous power conditions, of a rate of climb of 700 feet per minute if it has retractable landing gear and of 500 feet per minute if it has fixed landing gear, and
  - (ii) the weight at which the aeroplane is capable, in the en route configuration and if it is necessary for it to be flown solely by reference to instruments for any period before reaching the minimum altitude for safe flight on the first stage of the route to be flown, stated in, or calculated from the information contained in, the operations manual relating to the aeroplane and, with one power unit inoperative, of a rate of climb of 150 feet per minute.
- (b) The distance required by the aeroplane to attain a height of 50 feet, with all power units operating within the maximum take-off power conditions specified, when multiplied by a factor of 1.33 does not exceed the emergency distance available at the aerodrome at which the take-off is to be made. The distance required by the aeroplane to attain a height of 50 feet shall be that appropriate to:
  - (i) the weight of the aeroplane at the commencement of the take-off run;
  - (ii) the altitude at the aerodrome;

- (iii) the air temperature at the aerodrome; and
- (iv) not more than 50 per cent of the reported wind component opposite to the direction of take-off or not less than 150 per cent of the reported wind component in the direction of take-off,

do not exceed the take-off run available at the aerodrome at which the take-off is to be made.

- (c) The aeroplane will, in the meteorological conditions expected for the flight, in the event of any one power unit becoming inoperative at any point on its route or on any planned diversion therefrom, and with the other power unit or power units, if any, operating within the specified maximum continuous power conditions, be capable of continuing the flight at altitudes not less than the relevant minimum altitude for safe flight stated in, or calculated from the information contained in, the operations manual to a point 1,000 feet above a place at which a safe landing can be made:

Provided that in assessing the ability of the aeroplane to satisfy this condition it shall not be assumed to be capable of flying at any point on its route or on any planned diversion therefrom at an altitude exceeding that at which it is capable of a rate of climb with all power units operating within the maximum continuous power conditions specified of 150 feet per minute and if it is necessary for it to be flown solely by reference to instruments, be capable, with one power unit inoperative, of a rate of climb of 100 feet per minute.

- (d) The landing weight of the aeroplane for the altitude and the expected air temperature for the estimated time of landing at the aerodrome at which it is intended to land and at any alternate aerodrome will not exceed the maximum landing weight specified:
  - (i) at which the aeroplane is capable, in the en route configuration and with all power units operating within the specified maximum continuous power conditions, of a rate of climb of 700 feet per minute if it has retractable landing gear and of 500 feet per minute if it has fixed landing gear, and
  - (ii) at which the aeroplane is capable in the en route configuration and if it is necessary for it to be flown solely by reference to instruments for any period after leaving the minimum altitude for safe flight on the last stage of the route to be flown, stated in, or calculated from the information contained in, the operations manual relating to the aeroplane and with one power unit inoperative, of a rate of climb of 150 feet per minute.

- (e) The landing distance required does not, at the aerodrome at which it is intended to land and at any alternate aerodrome, exceed 70 per cent of the landing distance available on the most suitable runway for a landing in still air conditions, and for the purposes of this sub-paragraph the distance required to land from a height of 50 feet shall be taken to be that specified as being appropriate to:
  - (i) the landing weight;
  - (ii) the altitude at the aerodrome; and
  - (iii) the temperature in the specified international standard atmosphere appropriate to the altitude at the aerodrome.

(2) An aeroplane designated as aforesaid as an aeroplane of performance group E shall not fly for the purpose of public transport at night or when the cloud ceiling or visibility prevailing at the aerodrome of departure and forecast for the estimated time of landing at the aerodrome at which it is intended to land and at any alternate aerodrome are less than 1,000 feet and one nautical mile respectively:

Provided that the foregoing prohibition shall not apply if the aeroplane is capable, in the en route configuration and with one power unit inoperative, of a rate of climb of 150 feet per minute.

*Weight and Performance of Public Transport Aeroplanes classified as Aeroplanes of Performance Group X in their Certificate of Airworthiness*

**8.** With reference to Article 29(1) an aeroplane in respect of which there is in force under this Order a certificate of airworthiness designating the aeroplane as being of performance group X shall not fly for the purpose of public transport unless the weight of the aeroplane at the commencement of the take-off run is such that the following conditions are satisfied:

- (1) (i) That weight does not exceed the maximum take-off weight specified for the altitude at the aerodrome at which the take-off is to be made, or for the altitude and the air temperature at such aerodrome, as the case may be.
- (ii) The minimum effective take-off runway length required, specified as being appropriate to:
  - (a) the weight of the aeroplane at the commencement of the take-off run;
  - (b) the altitude at the aerodrome;
  - (c) the air temperature at the time of take-off;

- (d) the condition of the surface of the runway from which the take-off will be made;
- (e) the overall slope of the take-off run available; and
- (f) not more than 50 per cent of the reported wind component opposite to the direction of take-off or not less than 150 per cent of the reported wind component in the direction of take-off,

do not exceed the take-off run available at the aerodrome at which the take-off is to be made.

- (iii) (a) The take-off flight path with one power unit inoperative, specified as being appropriate to:
  - (i) the weight of the aeroplane at the commencement of the take-off run;
  - (ii) the altitude at the aerodrome; and
  - (iii) not more than 50 per cent of the reported wind component opposite to the direction of take-off or not less than 150 per cent of the reported wind component in the direction of take-off,

and plotted from a point 50 feet above the end of the minimum effective take-off runway length required at the aerodrome at which the take-off is to be made, shows that the aeroplane will thereafter clear any obstacle in its path by a vertical interval of not less than the greater of 50 feet or 35 feet plus one hundredth of the distance from the point on the ground below the intended line of flight of the aeroplane nearest to the obstacle to the end of the take-off distance available, measured along the intended line of flight of the aeroplane.

- (b) For the purpose of sub-paragraph (a) an obstacle shall be deemed to be in the path of the aeroplane if the distance from the obstacle to the nearest point on the ground below the intended line of flight does not exceed:
  - (i) a distance of 60 metres plus half the wing span of the aeroplane plus one eighth of the distance from such point to the end of the take-off distance available measured along the intended line of flight; or
  - (ii) 1,500 metres,

whichever is the less.

- (c) In assessing the ability of the aeroplane to satisfy this condition, insofar as it relates to flight path, it shall not be assumed to make a change of direction of a radius less than the radius of steady turn corresponding to an angle of bank of 15°.
- (2) (i) (a) Subject to sub-paragraph (b), the weight of the aeroplane at any point on the route or any planned diversion therefrom, having regard to the fuel and oil expected to be consumed up to that point, shall be such that the aeroplane, with one power unit inoperative and the other power unit or units operating within the maximum continuous power conditions specified, will be capable of a rate of climb of at least  $K(V_{so}/100)^2$  feet per minute at an altitude not less than the minimum altitude for safe flight stated in or calculated from the information contained in the operations manual, where  $V_{so}$  is in knots and  $K$  has the value of  $797 - 1060/N$ ,  $N$  being the number of power units installed.
  - (b) As an alternative to (a), the aeroplane may be flown at an altitude from which, in the event of failure of one power unit, it is capable of reaching an aerodrome where a landing can be made in accordance with condition (3)(ii) in this Regulation relating to an alternate aerodrome. In that case the weight of the aeroplane shall be such that, with the remaining power unit or units operating within the maximum continuous power conditions specified, it is capable of maintaining a minimum altitude on the route to such aerodrome of 2,000 feet above all obstacles within 10 nautical miles on either side of the intended track:

Provided that where the operator of the aeroplane is satisfied, taking into account the navigation aids which can be made use of by the aeroplane on the route, that the commander of the aeroplane will be able to maintain his intended track on that route within a margin of 5 nautical miles, the foregoing provisions of this sub-paragraph shall have effect as if 5 nautical miles were substituted therein for 10 nautical miles and

- (aa) the rate of climb, specified for the appropriate weight and altitude, used in calculating the flight path shall be reduced by an amount equal to  $K(V_{so}/100)^2$  feet per minute;
- (bb) the aeroplane shall comply with the climb requirements of condition of 2(i)(a) at 1,000 feet above the chosen aerodrome;
- (cc) account shall be taken of the effect of wind and temperature on the flight path; and

- (dd) the weight of the aeroplane may be assumed to be progressively reduced by normal consumption of fuel and oil.
  - (ii) An aeroplane having four power units shall, if any two power units become inoperative at any point along the route or any planned diversion therefrom, being a point more than 90 minutes flying time (assuming all power units to be operating) from the nearest aerodrome at which a landing can be made in compliance with condition (3)(ii) of this Regulation relating to an alternate aerodrome, be capable of continuing the flight at an altitude of not less than 1,000 feet above ground level to a point above that aerodrome. In assessing the ability of the aeroplane to satisfy this condition, it shall be assumed that the remaining power units will operate within the specified maximum continuous power conditions, and account shall be taken of the temperature and wind conditions expected for the flight.
- (3)
- (i) The landing weight of the aeroplane will not exceed the maximum landing weight specified for the altitude at the aerodrome at which it is intended to land and at any alternate aerodrome.
  - (ii) The required landing runway lengths respectively specified as being appropriate to the aerodromes of intended destination and the alternate aerodromes do not exceed at the aerodrome at which it is intended to land or at any alternate aerodrome, as the case may be, the landing distance available on:
    - (a) the most suitable runway for landing in still air conditions; and
    - (b) the runway that may be required for landing because of the forecast wind conditions,

the required landing runway lengths being taken to be those specified as being appropriate to:

- (aa) the landing weight;
- (bb) the altitude at the aerodrome;
- (cc) still air conditions in the case of the most suitable runway for a landing in still air conditions; and
- (dd) not more than 50 per cent of the forecast wind component opposite to the direction of landing or not less than 150 per cent of the forecast wind component in the direction of landing in the case of the runway that may be required for landing because of the forecast wind conditions.

*Noise and vibration caused by aircraft on aerodromes*

**9.** With reference to Article 73, the conditions under which noise and vibration may be caused by aircraft (including military aircraft) on Government aerodromes, licensed aerodromes or on aerodromes at which the manufacture, repair or maintenance of aircraft is carried out by persons carrying on business as manufacturers or repairers of aircraft, shall be as follows, that is to say, that, whether in the course of the manufacture of the aircraft or otherwise -

- (a) the aircraft is taking off or landing, or
- (b) the aircraft is moving on the ground or water, or
- (c) the engines are being operated in the aircraft -
  - (i) for the purpose of ensuring their satisfactory performance,
  - (ii) for the purpose of bringing them to a proper temperature in preparation for, or at the end of, a flight, or
  - (iii) for the purpose of ensuring that the instruments, accessories or other components of the aircraft are in a satisfactory condition.

*Certificates of Maintenance, Release and Compliance - issue by maintenance engineers licensed by specified countries*

**10.** With reference to Article 9(4), Article 10(3), and Article 11(5) the following countries are specified -

Antigua

AustraliaBahamas

Barbados

British Honduras

British Virgin Islands

State of Brunei

Burma

Canada

Cayman Islands

Dominica



Ghana  
Grenada  
Guyana  
Hong Kong  
India  
Jamaica  
Kenya  
Kuwait  
Malawi  
Malaysia  
Montserrat  
New Zealand  
Pakistan  
Republic of Ireland  
Republic of South Africa  
Sri Lanka  
St. Christopher, Nevis  
and Anguilla  
St. Lucia  
St. Vincent  
Singapore  
The Sudan  
Trinidad and Tobago  
Turks and Caicos Islands  
Uganda

United Kingdom

United Republic of Tanzania

Zambia

*Radio Navigational Equipment to be carried in aircraft*

**11** (1) This Regulation shall apply to all aircraft of over 2,300 kg. maximum total weight authorised when flying for the purpose of public transport.

(2) (a) For the purpose of Scale B in paragraph 3 of Schedule 6 radio navigational equipment shall be provided, subject to the provisions of sub-paragraph (b) of this paragraph, in all aircraft to which this Regulation applies in accordance with the following Table. The numbered areas in column 1 of that Table are more particularly described in paragraph (3) of this Regulation, and the letters in column 2 have the meanings assigned to them by paragraph (4) of this Regulation:

Table

Column 1	Column 2
Area in which the aircraft is flying	Combination of Equipment to be carried
Area 1	Either A, B, C, D or E
Area 2	Either A, C, D or E
Area 3	Either A, C or E
Area 4	D or E
All other areas	E

(b) Where not more than one item of equipment in a combination of equipment carried in an aircraft pursuant to this Regulation is unserviceable when the aircraft is about to begin a flight, the aircraft may nevertheless take off on that flight if -

- (i) it is not reasonably practicable for the repair or replacement of that item to be carried out before the beginning of the flight; and
- (ii) the aircraft has not made more than one complete flight since the item was last serviceable; and
- (iii) the commander of the aircraft has satisfied himself that taking into account the latest information available as to the route and aerodrome to be used (including any planned diversion), and the weather

conditions likely to be encountered, the flight can be made safely and in accordance with any relevant requirements of air traffic control,

and in such case the commander of the aircraft shall cause written particulars of the flight, and the reasons for making it, to be given to the Minister within 10 days thereafter.

(3) The Areas 1 to 4 referred to in column 1 of the Table in the preceding paragraph are as follows:

(a) *Area 1*

The area enclosed by the notified boundaries of the United Kingdom Flight Information Regions.

(b) *Area 2*

The area enclosed by rhumb lines joining successively the following points, but excluding area 1:

62°00'N 10°00'W	63°00'N 08°00'W	63°00'N 03°00'W
62°00'N 00°45'W	58°50'N 06°00'E	58°50'N 15°00'E
61°45'N 15°00'E	61°45'N 25°00'E	60°15'N 24°00'N
58°20'N 25°00'E	54°15'N 13°45'E	50°45'N 15°00'E
48°00'N 10°00'E	48°00'N 06°20'E	44°00'N 06°20'E
44°00'N 01°30'W	46°00'N 02°00'W	46°00'N 09°00'W
54°34'N 08°00'W	54°34'N 10°00'W	62°00'N 10°00'W

(c) *Area 3*

The area enclosed by rhumb lines joining successively the following points:

61°45'N 15°00'E	61°45'N 12°30'E	63°30'N 12°30'E
63°30'N 18°00'E	65°00'N 14°45'E	66°30'N 16°45'E
66°30'N 27°00'E	65°30'N 28°30'E	61°45'N 25°00'E
61°45'N 15°00'E		

(d) *Area 4*

The area enclosed by rhumb lines joining successively the following points, but excluding area 1 and 2:

62°00'N 10°00'W	63°00'N 08°00'W	63°00'N 03°00'W
62°00'N 00°45'W	62°00'N 04°00'E	65°00'N 10°00'E
68°30'N 13°00'E	68°30'N 23°00'E	66°30'N 23°00'E
66°30'N 16°45'E	65°00'N 14°45'E	63°30'N 18°00'E
63°30'N 12°30'E	61°45'E 12°30'E	61°45'N 26°00'E
58°20'N 24°00'E	50°30'N 17°30'E	41°30'N 23°15'E
41°30'N 30°00'E	40°00'N 37°00'E	30°00'N 37°00'E
30°00'N 10°00'W	62°00'N 10°00'W.	

(4) Each of the letters in Column 2 of the Table in paragraph (2)(a) of this Regulation shall signify the combination of equipment which is specified opposite that letter in columns 2 and 3 of the following Table. The Roman numerals in column 3 of the last-mentioned Table have the meanings assigned to them in paragraph (5) of this Regulation:

Table		
<i>Column 1</i> <i>Reference letter</i> <i>of combination</i> <i>of Equipment</i>	<i>Column 2</i> <i>Single or duplicate</i> <i>Equipment</i>	<i>Column 3</i> <i>Items of Equipment</i> <i>in the combination</i>
A	Single	(i),(ii),(iii) (iv) and (v)
B	Duplicate Single Single Single	(i) (ii) (iii) (v)
C	Duplicate Single Single Single	(i) (ii) (iv) (v)
	Single	(iii)

D	Duplicate	(iv)
	Single	(v)
E	Duplicate	(iii)
	Single	(iv)
	Single	(v)

(5) The Roman numerals indicating the items of equipment in column 3 of the Table in the preceding paragraph signify the following-

- (i) equipment which will enable the aircraft to be navigated by means of signals received from radio navigation land stations forming part of the Decca radio navigation system;
- (ii) a flight log intended to operate with the equipment described in the preceding paragraph and to display on a chart to the pilot at the controls of the aircraft a continuous and instantaneous pictorial plot of the path of the aircraft;
- (iii) automatic direction finding equipment which indicates to the pilot at the controls of the aircraft the bearing of any radio station transmitting signals in the low and medium frequency bands received by such equipment.
- (iv) equipment capable of giving to the pilot at the controls of the aircraft visual indications of bearings of the aircraft by means of signals received from very high frequency omni-directional radio ranges;
- (v) a VHF receiver capable of receiving signals from a 75MHz marker beacon.

*Aeroplanes flying for the purpose of public transport of passengers - Aerodrome facilities for approach to landing and landing*

**12** (1) This Regulation shall apply to every aeroplane registered in Seychelles engaging on a flight for the purpose of public transport of passengers on a scheduled journey and to every aeroplane so registered whose maximum total weight authorised exceeds 5,700 kg. engaging on such a flight otherwise than on a scheduled journey.

(2) For the purposes of Article 27(1)(c), the following manning and equipment are specified in relation to aerodromes intended to be used for landing or as an alternate aerodrome by aircraft to which this Regulation applies:

- (a) air traffic control service, including the reporting to aircraft of the current meteorological conditions at the aerodrome;

- (b) very high frequency radiotelephony;
- (c) at least one of the following radio navigational aids, either at the aerodrome or elsewhere, and in either case for the purpose of assisting the pilot in locating the aerodrome and in making an approach to landing there:
  - (i) radio direction finding equipment utilising emissions in the very height frequency bands;
  - (ii) a non-directional radio beacon transmitting signals in the low or medium frequency band;
  - (iii) very high frequency omni-directional radio range;
  - (iv) radio navigation land stations forming part of the Decca radio navigation system;
  - (v) radar equipment.

It shall be sufficient if the equipment specified in sub-paragraph (c) is provided, even if for the time being it is not in operation.

(3) An aircraft to which this Regulation applies shall not land or mark an approach to landing at any aerodrome unless services and equipment according with paragraph (2) of this Regulation are provided and are in operation at that aerodrome, and can be made use of by that aircraft, and, in the case of the navigation aids specified in sub-paragraph (c), items (i) to (iv), instructions and procedures for the use of the aid are included in the operations manual. A person shall be deemed not to have contravened the provisions of this paragraph if he proves that -

- (a) for the time being use could not be made of the radio navigation aids provided under paragraph (2)(c) whether by reason of those aids not being in operation or of the unserviceability of equipment of the aircraft itself, and
- (b) the approach to landing was made in accordance with instructions and procedures appropriate to that circumstance and included in the operations manual.

(4) An aircraft to which this Regulation applies shall, without prejudice to the requirements of Regulation 11, be equipped with the equipment necessary to enable use to be made of at least one of the navigation aids specified in paragraph 2(c) of this Regulation and in use for landing at the aerodrome, and in particular the equipment for use with the radio navigation land stations referred to in paragraph (2)(c)(iv) of this Regulation shall include a flight log designed to operate with that equipment and to display on a chart to the pilot at the controls of the aircraft a continuous and instantaneous pictorial plot of the path of the aircraft. Nothing in this paragraph shall

require the duplication of any equipment carried in pursuance of any other provision of this Order or of any regulation made thereunder.

*Pilot Maintenance - specified repairs or replacements*

**13.** With reference to Article 11(2) the following repairs or replacements are hereby specified:

- (1) Replacement of landing gear tyres, landing skids or skid shoes.
- (2) Replacement of elastic shock absorber cord units on landing gear where special tools are not required.
- (3) Replacement of defective safety wiring or split pins excluding those in engine, transmission, flight control and rotor systems.
- (4) Patch-repairs to fabric not requiring rib stitching or the removal of structural parts or control surfaces, if the repairs do not cover up structural damage and do not include repairs to rotor blades.
- (5) Repairs to upholstery and decorative furnishing of the cabin or cockpit interior when repair does not require dismantling of any structure or operating system or interfere with an operating system or affect the structure of the aircraft.
- (6) Repairs, not requiring welding, to fairings, non-structural cover plates and cowlings.
- (7) Replacement of side windows where that work does not interfere with the structure or with any operating systems.
- (8) Replacement of safety belts or safety harness.
- (9) Replacement of seats or seat parts not involving dismantling of any structure or of any operating system.
- (10) Replacement of bulbs, reflectors, glasses, lenses or lights.
- (11) Replacement of any cowling not requiring removal of the propeller, rotors or disconnection of engine or flight controls.
- (12) Replacement of unserviceable sparking plugs.
- (13) Replacement of batteries.
- (14) Replacement of wings and tail surfaces and controls, the attachments of which are designed to provide for assembly immediately before such flight and dismantling after each flight.

- (15) Replacement of main rotor blades that are designed for removal where special tools are not required.
- (16) Replacement of generator and fan belts designed for removal where special tools are not required.

*Mandatory Reporting - specified reportable occurrences, time and manner of reporting and information to be reported*

**14** (1) With reference to Article 79(1) of this Order, the following reportable occurrences are specified, that is to say those:-

- (a) involving damage to an aircraft;
- (b) involving injury to a person;
- (c) involving the impairment during a flight of the capacity of a member of the flight crew of an aircraft to undertake the functions to which his licence relates;
- (d) involving the use in flight of any procedures taken for the purpose of overcoming an emergency;
- (e) involving the failure of an aircraft system or of any equipment of an aircraft;
- (f) arising from the control of an aircraft in flight by its flight crew;
- (g) arising from failure or inadequacy of facilities or services on the ground used or intended to be used for purposes of or in connection with the operation of aircraft;
- (h) arising from the loading of the carriage of passengers, cargo (including mail) or fuel,

and those which are not referred to in sub-paragraph (a) to (h) of this Regulation but which, in the opinion of a person referred to in sub-paragraphs (a) to (e) of Article 79(1) of this Order, constitute an occurrence endangering, or which if not corrected would endanger, the safety of an aircraft, its occupants or any other person.

(2) For the purposes of this Regulation, an aircraft system includes the flight control, power plant, fuel, hydraulic, pneumatic, pressurisation, electrical, navigation and any other system of the aircraft.

(3) With reference to Article 79(1) of this Order, a report containing the information referred to in paragraph (4) of this Regulation shall be despatched in writing and by the quickest available means to the Minister within 96 hours of the reportable occurrence coming to the knowledge of the person making the report:



Provided that if at that time any of the said information is not in the possession of that person, he shall despatch that information to the Minister in writing and by the quickest available means within 96 hours of its coming into his possession.

(4) With reference to Article 79(1) of this Order a report shall, as far as possible, contain the following information:-

- (a) The type, series and registration marks of the aircraft concerned;
- (b) The name of the operator of the aircraft;
- (c) The date of the reportable occurrence;
- (d) If the person making the report has instituted an investigation into the reportable occurrence, whether or not this has been completed;
- (e) A description of the reportable occurrence, including its effects and any other relevant information;
- (f) In the case of a reportable occurrence which occurs during flight-
  - (i) The Greenwich Mean Time of the occurrence;
  - (ii) The last point of departure and the next point of intended landing of the aircraft at that time;
  - (iii) The geographical position of the aircraft at that time;
- (g) In the case of a defect in or malfunctioning of an aircraft or any part or equipment of an aircraft, the name of the manufacturer of the aircraft, part or equipment, as the case may be, and, where appropriate, the part number and modification standard of the part or equipment and its location on the aircraft;
- (h) The signature and name in block of the person making the report, the name of his employer and the capacity in which he acts for that employer;
- (i) In the case of a report made by the commander of an aircraft or a person referred to in sub-paragraph (c) or (d) of Article 79(1) of this Order the address or telephone number at which communications should be made to him, if different from that of his place of employment.

#### ANNEX TO SCHEDULE 15

#### Regulation 3

WEIGHT AND PERFORMANCE OF PUBLIC TRANSPORT  
AEROPLANES HAVING NO PERFORMANCE  
GROUP CLASSIFICATION IN THEIR CERTIFICATES OF  
AIRWORTHINESS

Conditions (1) and (2) apply to all aeroplanes to which Regulation 3 applies;

Conditions (3) to (10) apply to all aeroplanes to which Regulation 3 applies -

- (i) of which the specified maximum total weight authorised exceeds 5,700 kg., or
- (ii) of which the specified maximum total weight authorised does not exceed 5,700 kg. and which comply with neither condition (1)(a) nor condition 1(b)'

Conditions (11) to (18) inclusive apply to all aeroplanes to which Regulation 3 applies of which the specified maximum total weight authorised does not exceed 5,700 kg., and which comply with condition (1)(a) or condition (1)(b) or with both those conditions.

*All aeroplanes*

- (1) Either -
  - (a) the wing loading of the aeroplane does not exceed 20 lb per square foot; or
  - (b) the stalling speed of the aeroplane in the landing configuration does not exceed 60 knots; or
  - (c) the aeroplane, with any one of its power units inoperative and the remaining power unit or units operating within the maximum continuous power conditions specified, is capable of a gradient of climb of at least 1 in 200 at an altitude of 5,000 feet in specified international standard atmosphere.

(2) The weight of the aeroplane at the commencement of the take-off run does not exceed the maximum take-off weight, if any, specified for the altitude and the air temperature at the aerodrome at which the take-off is to be made.

*Aeroplanes of a specified maximum total weight authorised exceeding 5,700 kg. and aeroplanes of a specified maximum total weight authorised not exceeding 5,700 kg. which comply with neither condition (1)(a) nor condition (1)(b).*

(3) (a) The distance required by the aeroplane to attain a height of 50 feet, with all power units operating within the maximum take-off power conditions specified

does not exceed the take-off run available at the aerodrome at which the take-off is to be made.

(b) The distance required by the aeroplane to attain a height of 50 feet with all power units operating within the maximum take-off power conditions specified, when multiplied by a factor of either 1.33 for aeroplanes having two power units or by a factor of 1.18 for aeroplanes having four power units, does not exceed the emergency distance available at the aerodrome at which the take-off is to be made.

(c) For the purposes of sub-paragraphs (a) and (b) the distance required by the aeroplane to attain a height of 50 feet shall be that appropriate to:

- (i) the weight of the aeroplane at the commencement of the take-off run;
- (ii) the altitude at the aerodrome;
- (iii) the air temperature at the aerodrome;
- (iv) the condition of the surface of the runway from which the take-off will be made;
- (v) the slope of the surface of the aerodrome in the direction of take-off over the take-off run available and the emergency distance available, respectively; and
- (vi) not more than 50 per cent of the report wind component opposite to the direction of take-off or not less than 150 per cent of the reported wind component in the direction of take-off.

(4) (a) The take-off flight path with one power unit inoperative and the remaining power unit or units operating within the maximum take-off power conditions specified, appropriate to:

- (i) the weight of the aeroplane at the commencement of the take-off run;
- (ii) the altitude at the aerodrome;
- (iii) the air temperature at the aerodrome;
- (iv) not more than 50 per cent of the reported wind component opposite to the direction of take-off or not less than 150 per cent of the report wind component in the direction of take-off,

and plotted from a point 50 feet above the end of the appropriate factored distance required for take-off under condition (3)(b) of this Annex at the aerodrome at which the take-off is to be made, shows that the aeroplane will clear any obstacle in its path by a

vertical interval of at least 35 feet except that if it is intended that an aeroplane shall change its direction by more than 15° the vertical interval shall be not less than 50 feet during the change of direction.

(b) For the purpose of sub-paragraph (4)(a) an obstacle shall be deemed to be in the path of the aeroplane if the distance from the obstacle to the nearest point on the ground below the intended line of flight does not exceed:

- (i) a distance of 60 metres plus half the wing span of the aeroplane plus one-eighth of the distance from such point to the end of the take-off distance available, measured along the intended line of flight; or
- (ii) 1,500 metres,

whichever is the less.

(c) In assessing the ability of the aeroplane to satisfy this condition, it shall not be assumed to make a change of direction of a radius less than a radius of steady turn corresponding to an angle of bank of 15°.

(5) The aeroplane will, in the meteorological conditions expected for the flight, in the event of any one power unit becoming inoperative at any point on its route or on any planned diversion therefrom and with the other power unit or units operating within the maximum continuous power conditions specified, be capable of continuing the flight clearing obstacles within 10 nautical miles either side of the intended track by a vertical interval of at least:

- (a) 1,000 feet when the gradient of the flight path is not less than zero; or
- (b) 2,000 feet when the gradient of the flight path is less than zero,

to an aerodrome at which it can comply with condition (9), and on arrival over such aerodrome the flight path shall have a gradient of not less than zero at 1,500 feet above the aerodrome.

For the purpose of this condition the gradient of climb of the aeroplane shall be taken to be one per cent less than that specified.

(6) The aeroplane will, in the meteorological conditions expected for the flight, at any point on its route or on any planned diversion therefrom be capable of climbing at a gradient of at least 1 in 50, with all power units operating within the maximum continuous power conditions, specified at the following altitudes:

- (a) the minimum altitudes for safe flight on each stage of the route to be flown or of any planned diversion therefrom specified in, or

calculated from the information contained in, the operations manual relating to the aeroplane; and

- (b) the minimum altitudes necessary for compliance with conditions (5) and (7), as appropriate.

(7) If on the route to be flown or any planned diversion therefrom, the aeroplane will be engaged in a flight over water during which at any point it may be more than 90 minutes flying time in still air from the nearest shore, it will in the event of two power units becoming inoperative during such time and with the other power unit or units operating within the maximum continuous power conditions specified be capable of continuing the flight having regard to the meteorological conditions expected for the flight, clearing all obstacles within 10 nautical miles either side of the intended track by a vertical interval of at least 1,000 feet, to an aerodrome at which a safe landing can be made.

(8) The landing weight of the aeroplane will not exceed the maximum landing weight, if any, specified for the altitude and the expected air temperature for the estimated time of landing at the aerodrome at which it is intended to land and at any alternate aerodrome.

(9) The distance required by the aeroplane to land from a height of 50 feet does not, at the aerodrome at which it is intended to land, exceed 60 per cent of the landing distance available on -

- (i) the most suitable runway for a landing in still air conditions; and
- (ii) the runway that may be required for landing because of the forecast wind conditions; provided that if an alternate aerodrome is designated in the flight plan the landing distance required at the aerodrome at which it is intended to land shall not exceed 70 per cent of that available on the runway.

The distance required to land from a height of 50 feet shall be taken to be that appropriate to -

- (a) the landing weight;
- (b) the altitude at the aerodrome;
- (c) the temperature in the specified international standard atmosphere appropriate to the altitude at the aerodrome;
- (d)
  - (i) a level surface in the case of runways usable in both direction;
  - (ii) the average slope of the runway in the case of runways usable in only one direction; and

- (e) (i) still air conditions in the case of the most suitable runway for a landing in still air conditions; and
- (ii) not more than 50 per cent of the forecast wind component opposite to the direction of landing or not less than 150 per cent of the forecast wind component in the direction of landing in the case of the runway that may be required for landing because of the forecast wind conditions.

(10) The distance required by the aeroplane to land from a height of 50 feet does not, at any alternate aerodrome, exceed 70 per cent of the landing distance available on -

- (i) the most suitable runway for a landing in still air conditions; and
- (ii) the runway that may be required for landing because of the forecast wind conditions.

For the purpose of this condition the distance required to land from a height of 50 feet shall be determined in the manner provided in condition (9).

*Aeroplanes of a specified maximum total weight authorised not exceeding 5,700 kg. and which comply with either condition (1)(a) or condition (1)(b), or with both these conditions*

(11) If the aeroplane is engaged in a flight at night or when the cloud ceiling or visibility prevailing at the aerodrome of departure and forecast for the estimated time of landing at the aerodrome of destination or at any alternate aerodrome are less than 1,000 feet and one nautical mile respectively, it will, with any one of its power units inoperative and the remaining power unit or units operating within the maximum continuous power conditions specified, be capable of climbing at a gradient of at least 1 in 200 at an altitude of 2,500 feet in the specified international standard atmosphere.

(12) (a) The distance required by the aeroplane to attain a height of 50 feet with all power units operating within the maximum take-off power conditions specified, does not exceed the take-off run available at the aerodrome at which the take-off is to be made;

(b) The distance required by the aeroplane to attain a height of 50 feet with all power units operating within the maximum take-off power conditions specified, when multiplied by a factor of 1.33 does not exceed the emergency distance available at the aerodrome at which the take-off is to be made;

(c) For the purposes of sub-paragraphs (a) and (b) the distance required by the aeroplane to attain a height of 50 feet shall be that appropriate to:

- (i) the weight of the aeroplane at the commencement of the take-off run;

- (ii) the altitude at the aerodrome;
- (iii) the temperature in the specified international standard atmosphere appropriate to the altitude at the aerodrome or, if greater, the air temperature at the aerodrome less 15°centigrade;
- (iv) the slope of the surface of the aerodrome in the direction of take-off over the take-off run available and the emergency distance available respectively; and
- (v) not more than 50 per cent of the reported wind component opposite to the direction of take-off or not less than 150 per cent of the reported wind component in the direction of take off.

(13) The take-off flight path, with all power units operating within the maximum take-off power conditions specified, appropriate to:

- (i) the weight of the aeroplane at the commencement of the take-off run;
- (ii) the altitude at the aerodrome;
- (iii) the temperature in the specified international standard atmosphere appropriate to the altitude at the aerodrome, or, if greater, the air temperature at the aerodrome less than 15°centigrade; and
- (iv) not more than 50 per cent of the reported wind component opposite to the direction of take-off or not less than 150 per cent of the reported wind component in the direction of take-off,

and plotted from a point 50 feet above the end of the factored distance required for take-off under condition (12)(b), at the aerodrome at which the take-off is to be made, shows that the aeroplane will clear any obstacle lying within 60 metres plus half the wing span of the aeroplane on either side of its path by a vertical interval of at least 35 feet. In assessing the ability of the aeroplane to satisfy this condition it shall not be assumed to make a change of direction of a radius less than a radius of steady turn corresponding to an angle of bank of 15°.

(14) The aeroplane will, in the meteorological conditions expected for the flight, in the event of any one power unit becoming inoperative at any point on its route or on any planned diversion therefrom and with the other power unit or units, if any, operating within the maximum continuous power conditions specified, be capable of continuing the flight so as to reach a point above a place at which a safe landing can be made at a suitable height for such landing.

(15) The aeroplane will, in the meteorological conditions expected for the flight, at any point on its route or any planned diversion therefrom, be capable of climbing at a gradient of at least 1 in 50, with all power units operating within the maximum continuous power conditions specified at the following altitudes:

- (a) the minimum altitudes for safe flight on each stage of the route to be flown or on any planned diversion therefrom specified in, or calculated from, the information contained in the operations manual relating to the aeroplane; and
- (b) the minimum altitudes necessary for compliance with condition (14).

(16) If on the route to be flown or any planned diversion therefrom the aeroplane will be engaged in a flight over water during which at any point it may be more than 30 minutes flying time in still air from the nearest shore, it will, in the event of one power unit becoming inoperative during such time and with the other power unit or units operating within the maximum continuous power conditions specified, be capable of climbing at a gradient of at least 1 in 200 at an altitude of 5,000 feet in the specified international standard atmosphere.

(17) The landing weight of the aeroplane will not exceed the maximum landing weight, if any, specified for the altitude and the expected air temperature for the estimated time of landing at the aerodrome at which it is intended to land and at any alternate aerodrome.

(18) The distance required by the aeroplane to land from a height of 50 feet does not at the aerodrome at which it is intended to land and at any alternate aerodrome, exceed 70 per cent, or, if a visual approach and landing will be possible in the meteorological conditions forecast for the estimated time of landing, 80 per cent, if the landing distance available on:

- (i) the most suitable runway for a landing in still air conditions; and
- (ii) the runway that may be required for landing because of the forecast wind conditions,

the distance required to land from a height of 50 feet being taken to be that appropriate to:

- (a) the landing weight;
- (b) the altitude at the aerodrome;
- (c) the temperature in the specified international standard atmosphere appropriate to the altitude at the aerodrome;
- (d)
  - (i) a level surface in the case of runways usable in both directions;
  - (ii) the average slope of the runway in the case of runways usable in only one direction; and
- (e)
  - (i) still air conditions in the case of the most suitable runway for a landing in still air conditions;



- (ii) not more than 50 per cent of the forecast wind component opposite to the direction of landing or not less than 150 per cent of the forecast wind component in the direction of landing in the case of the runway that may be required for landing because of the forecast wind conditions.

#### EXPLANATORY NOTE

This Order contains the provisions relating to registration of aircraft, the certification of operators of aircraft, the certification of airworthiness of aircraft, operation of aircraft and control of air traffic, noise certification, personnel licensing, the licensing of aerodromes, the validation of any certificate or licence and the approval of persons and equipment, in Seychelles.

---

Article 76 of the Air Navigation (Overseas Territories) Order

S.I 8 of 1974.

**\*The Seychelles International Airport (Customs Aerodrome) Order**

*[28th January 1974]*

**1** This Order may be cited as the Seychelles International Airport (Customs Aerodrome) Order.

**2** The Seychelles International Airport is hereby designated as a place of landing or departure of aircraft for the purpose of the enactments for the time being in force relating to customs.

---

Article 91 of the Air Navigation (Overseas Territories) Order

S.I 69 of 1982  
S.I. 60 of 1983.  
S.I.21 of 2004

**The Air Navigation (Fees) Regulations**

*[1st January, 1983]*

1 These Regulations may be cited as the Air Navigation (Fees) Regulations.

2 (1) In these Regulations, the expression "the Order" means the Air Navigation (Overseas Territories) Order.

(2) Expressions used in these Regulations shall, unless the context otherwise requires, have the same meaning as in the Order.

3 The provisions of the Schedule to these Regulations shall have effect with respect to the fees to be paid in connection with the certificates, licences and other documents, and with examinations, tests, inspections, investigations, permissions and approvals, required by or for the purposes of the Order or any regulations made thereunder.

## SCHEDULE

### PART A FLIGHT CREW AND SIMULATOR LICENSING FEES 3

1. Fees .....	3
<i>Flight Crew Licensing</i> .....	3
<i>Assessments of Licensing Requirements</i> .....	4
<i>Ground Examinations</i> .....	4
<i>Administrative Fees</i> .....	5
<i>Validation of Flight Crew Licensing</i> .....	5
<i>Authorisation and Approval of Persons</i> .....	6
<i>Approval of Flight Simulators and their Use</i> .....	8
<i>Type Rating for New or Unusual Types of Aircraft</i> .....	9
<i>Approval of type Rating Organisations and Conversion Course</i> .	9
<i>Approval of Other Training Organisations and</i>	
<i>Conversion Courses</i> .....	10
<i>Authorisation and Approval of Medical Examiners</i> .....	11
<i>Medical Examiners for Personnel Licences</i> .....	11
<i>Copies of and Amendments to Documents</i> .....	11

2. DEFINITIONS .....	11
<b>PART B AIRWORTHINESS AND MAINTENANCE FEES</b>	<b>13</b>
1. FEES .....	13
<i>Certificate of Airworthiness – Series</i> .....	13
<i>Certificate of Airworthiness – Issue following prior revocation ..</i>	14
<i>Certificate of Airworthiness Renewal</i> .....	14
<i>Permit for Aircraft to Fly without Ceertificated of</i>	
<i>Airworthiness</i> .....	15
<i>Certificate of Airworthiness – Change of Category</i> .....	15
<i>Approval in Respect of Aircraft Equipment (excluding</i>	
<i>Engines) and Modification, Repair etc of such Equipment</i> .....	15
<i>Approval in Respect of the Modification, Repair etc. of Aircraft</i>	
<i>(excluding Engines</i> .....	16
<i>Variation and Concession</i> .....	17
<i>Approval of Persons</i> .....	17
<i>Certificate of Airworthiness for Export</i> .....	17
<i>Licensing of Aircraft Maintenance Engineers</i> .....	18
<i>Ground Examination</i> .....	18
<i>Administrative Fees</i> .....	19
<i>Validation of Aircraft Maintenance Engineer Licences</i> .....	19
<i>Copies of Documents</i> .....	19
<i>Time at which Fees are to be paid</i> .....	20
2. DEFINITIONS .....	20
<b>PART C FEES FOR AIR OPERATOR’S CERTIFICATE</b> .....	<b>22</b>
1. FEES .....	22

<i>Fees on Application for the grant of AOC</i> .....	22
<i>Fees on Application for Variation AOC</i> .....	23
<i>Fees on Application for renewal of an AOC</i> .....	23
<i>New Type of Aircraft-Additional Fee</i> .....	24
<i>Extended Twin Engine Operation</i> .....	24
<i>Special Operations</i> .....	24
<i>Exemptions</i> .....	24
<i>Copies of Documents</i> .....	24
2. DEFINITIONS .....	24
<b>PART D FEES FOR AERODROME LICENSING AERODROME</b>	<b>26</b>
1. FEES .....	26
<i>Grant and Renewal of Aerodrome licences</i> .....	26
<i>Grant and Renewal of Heliport licences</i> .....	26
<i>Heliport Inspections</i> .....	27
<i>Copies of Documents</i> .....	27
2. DEFINITIONS .....	27
<b>PART E FEES FOR AIRCRAFT REGISTRATION</b> .....	<b>28</b>
1. FEES .....	28
Certificate of Registration of an Aircraft .....	28
<i>Copies of Documents</i> .....	29
2. Definitions .....	30
<b>PART F ADDITIONAL FEES</b> .....	<b>29</b>
1. FEES .....	29
<i>Additional Fee where Functions are Performed Abroad</i> .....	30
<i>Assessment of Manuals</i> .....	30

## **PART A FLIGHT CREW AND SIMULATOR LICENSING FEES**

### **1. Fees**

Fees shall be payable to the Directorate as follows:

#### ***Flight Crew Licensing***

(1) Upon making an application for the grant, extension or renewal of a licence to act as a flight crew member, an applicant shall pay:

- (a) for the grant of a Professional Pilot's Licence, a Flight Navigator's Licence or a Flight Engineer's Licence including an initial type rating and instrument rating where these are including in the application, a fee of SR 1000.
- (b) for the renewal of a Professional Pilot's Licence, a Flight Navigator's Licence or a Flight Engineer's Licence, a fee of SR 800.
- (c) for the grant of a Private Pilot's Licence, a fee of SR 500.
- (d) for the renewal of a Private Pilot's Licence, a fee of SR 250.
- (e) for the grant or renewal of a Flight Radiotelephony Operator's Licence (except when the applicant is either the holder of a licence to act as Pilot, Flight Navigator or Flight Engineer, or the holder of a medical certificate), a fee of SR 150.

(2) Upon making an application for the inclusion or variation of a rating in a Professional Pilot's licence, a Private Pilot's Licence or in a Flight Engineer's Licence, the applicant shall pay:

- (a) for the inclusion of a second or subsequent type of aircraft in the aircraft rating, a fee of SR 500.
- (b) for the inclusion of a Flying Instructor's rating or an Assistant Flying Instructor's Rating (except when the applicant is the holder of a Private Pilot's Licence which includes, respectively for each case, a Flying Instructor's Rating or an Assistant Flying Instructor's Rating entitling the holder to give instruction in flying aircraft of the same types included in the application), a fee of SR 500.
- (c) for the variation of a Flying Instructor's rating or an Assistant Flying Instructor's Rating, a fee of SR 150.
- (d) for the inclusion of an Instrument rating (Aeroplanes) or Instrument rating (Helicopters), or specific type related Instrument Rating, except when the applicant is the holder of a Private Pilot's Licence which

includes the particular rating, or for the variation of such a rating, a fee of SR 500.

- (e) for the inclusion, variation or renewal of any other rating or qualification in a licence, a fee of SR 300.

### ***Assessments of Licensing Requirements***

(3) Upon making an application for a written assessment particular to that applicant of the evidence, examinations or tests which the Directorate will require in respect of his knowledge, experience, competence or skill in respect of a Professional Licence, a Private Pilot's Licence or a Flying Instructor's rating, the applicant shall pay a fee of SR 300.

### ***Ground Examinations***

(4) Upon making an application for an examination to be conducted by the Directorate for the inclusion of a rating therein or for any other purpose, the applicant shall pay:

- (a) for each initial or additional aircraft type rating examination in respect of an aircraft type for which no provision exists at an approved training organisation, a fee of SR 500 for Normal or Small Rotocraft Category certified aircraft types and SR 1000 for Commuter Category or Large Rotorcraft aircraft types.
- (b) for Aircraft Performance Group subjects, for each subject, a fee of SR 500.
- (c) for Seychelles Licence revalidation and ICAO Validation or Conversion examinations, Aviation Law and Procedures examinations, a fee of SR 500;
- (d) for any other ground examination, a fee of SR 250 per paper;

provided further that if the examination is to be conducted other than at a place specified by the Directorate the applicant shall pay in addition to the fee for that examination, a fee of such amount as may be decided by the Directorate having regard to the expense incurred by it.

### ***Administrative Fees***

- (5) Upon making an application for:
  - (a) an examination paper to be re-marked, the applicant shall pay a fee of SR 200 and the fee shall be refunded if a pass is subsequently awarded as a consequence of an error made by the Directorate:

- (b) the refund or transfer of fees or when an examination has been re-arranged at the request of the applicant, the applicant shall pay a fee of SR 200;
- (c) the issue of a duplicate or replacement examination result notification, the applicant shall pay a fee of SR 150.

#### ***Validation of Flight Crew Licences***

- (6) Upon making an application for the:
  - (a) issue of a certificate of validation of a licence the applicant shall pay a fee of SR 800.
  - (b) issue of a certificate of validation of a certificate forming part of a licence, the applicant shall pay a fee of SR 200.
  - (c) renewal of a certificate of validation of a licence the applicant shall pay a fee of SR 400.
  - (d) renewal of a certificate of validation of a certificate forming part of a licence the applicant shall pay a fee of SR 100.

#### ***Authorisation and Approval of Persons***

(7) Upon making an application for appointment or re-appointment as an authorised examiner or as a person approved to conduct courses of training, the applicant shall pay:

- (a) in the case of an application for appointment or re-appointment as an examiner authorised to conduct tests and to sign certificates of test and certificates of experience in respect of an aircraft class or type rating or for synthetic flight purposes:
  - (i) in respect of aircraft certificated for Single Pilot operation, a fee of SR 2000;
  - (ii) in respect of aircraft certificated for Multi Pilot operation, a fee of SR 2500;
  - (iii) in respect of aircraft certificated for Single Pilot operation and where the applicant is already authorised so to act in respect of another type or class of aircraft, a fee of SR 500;
- (b) in the case of an application for appointment or re-appointment as an examiner authorised to conduct tests and to sign certificates of test and certificates of experience in respect of Instrument Rating included in a pilot's licence:

- (i) in respect of aircraft certificated for Single Pilot operation, a fee of SR 2000;
  - (ii) in respect of aircraft certificated for Multi Pilot operation, a fee of SR 2500;
- (c) in the case of an application for appointment or re-appointment as an examiner authorised for the combined purposes of instrument and type ratings:
  - (i) in respect of aircraft certificated for Single Pilot operation, a fee of SR 2500;
  - (ii) in respect of aircraft certificated for Multi Pilot operation, a fee of SR 3000;
  - (iii) in the case of an application for appointment or re-appointment as an examiner authorised to conduct revalidation test for the purposes of sub-paragraphs 7(a), (b) and (c)
  - (aa) in respect of aircraft certificated for Single Pilot operation, a fee of SR 2500;
  - (bb) in respect of aircraft certificated for Multi Pilot operation, a fee of SR 3000.
- (d) in the case of an application for appointment or re-appointment as an examiner authorised to conduct tests and to sign certificates of test for a Flying Instructor's Rating, a Flying Instructor's Rating (restricted) or an assistant Flying Instructor's Rating, a fee of SR 2500;
- (e) in the case of an application for appointment or re-appointment as an examiner authorised to conduct tests and to sign certificates of test and certificates of experience in respect of an aircraft rating included in a Flight Engineer's Licence, a fee of SR 1500;
- (f) in the case of an application for appointment or re-appointment as an examiner authorised to conduct flight test and examinations and to sign certificates of test and certificates of experience in respect of the Private Pilot's Licence, a fee of SR 1500;
- (g) in the case of an application for appointment or re-appointment as an examiner authorised to conduct flight tests and to sign certificates of test and certificates of experience in respect of a Professional Pilot's Licence, a fee of SR 2500;
- (h) in the case of an application for appointment or re-appointment as an examiner authorised to conduct examinations and to sign certificates



of experience in respect of the Private Pilot's Licence, a fee of SR 1000;

- (i) in the case of an application for appointment as an examiner authorised to conduct examinations in respect of the Flight Radiotelephony Operator's Licence, a fee of SR 1000;
- (j) in the case of an application for re-appointment as an examiner authorised to conduct examinations in respect of the Flight Radiotelephony Operator's Licence, a fee of SR 500;
- (k) in the case of an application for appointment or re-appointment as a person approved to conduct courses of training in respect of the flight instructor, rating, flight instructor rating (restricted), type rating instructor rating (helicopter) on single pilot helicopter types, or instrument rating instructor rating or class rating instructor rating, a fee of SR 1000;
- (l) in the case of an application for appointment or re-appointment as a person approved to conduct courses of training in simulated instrument flight, a fee of SR 1000;
- (m) in the case of an application for a one-off approval of a person to conduct a course of training in simulated instrument flight, a fee of SR 500;
- (n) in the case of an application for appointment or re-appointment as a person authorised to carry out synthetic flight instruction on a flight simulator for type rating purposes only, and the instruction required for multi-crew co-operation, where the applicant does not hold a Professional Pilot's Licence, a fee of SR 1000;
- (o) in the case of an application for appointment or re-appointment as a person authorised to conduct skill tests for the issue of a Private Pilot's Licence (helicopter), type ratings on single pilot helicopters and for the revalidation or renewal of type ratings on single pilot helicopters, a fee of SR 1000.
- (p) in the case of an application for appointment or re-appointment as a person authorised to conduct Safety and Emergency Procedures training and examinations, a fee of SR 1000.

(8) Upon making an application for the amendment of the particulars set out on an appointment or re-appointment as an authorised examiner or as a person approved to conduct courses of training, the applicant shall pay a fee of SR 200.

#### ***Approval of Flight Simulators and their Use***

(9) Upon making an application for the approval, renewal or validation of approval of a flight simulator, the applicant shall pay:

- (a) for the first application for approval, a fee of SR 2500;
- (b) for the application for renewal of approval by a simulator operator, a fee of SR 1000;
- (c) for the first and any subsequent application for approval by an aircraft operator to use a simulator approved under sub-paragraph (a) and (b), a fee of SR 1000;
- (d) for an application for the approval of a flight simulator for the purpose only of its use on one test for a certificate of test, where the applicant holds or is employed by the holder of an Air Operator's Certificate, a fee of SR 700 and in any other case a fee of SR 500.

Provided that, where the total costs of the approval exceeds the amount stated above, the applicant shall pay a fee of such amount as may be decided by the Directorate of having regard to the expense incurred by it in carrying out the work.

#### ***Type Rating for New or Unusual Types of Aircraft***

(10) Upon an application being made for the inclusion in a pilot's licence of an aircraft rating in respect of an aircraft type where no application for an aircraft rating in respect of that type has been granted by the Directorate during the period of five years immediately preceding the date of the application in question, the applicant shall pay, in addition to any other fee payable by virtue of this Regulation in relation to that application, a fee of an amount decided by the Directorate having regard to the cost to the Directorate of:

- (a) training a member or employee of the Directorate to act as pilot in command of that type of aircraft; and
- (b) training a member or employee of the Directorate to a standard of technical knowledge of that type of aircraft which in the opinion of the Directorate will enable that member or employee of the Directorate to examine the applicant for the purposes of his application. The payment shall be made by the employer of the applicant if it is a term or condition of the applicant's employment that he apply for the rating and in any other case the payment shall be made by the applicant.

#### ***Approved of Type Rating Organisations and Conversion Courses***

- (11) (a) Upon making an application for initial approval as a type rating training organisation, the applicant shall pay SR 5000;

- (b) for each type to be included in the approval the applicant shall pay a fee according to weight, as detailed in the Table 1 hereof:
- (c) to add a type to an existing approval the applicant shall pay a fee according to weight, as detailed in Table 1 hereof:
- (d) upon making application for renewal of a type rating training organisation approval, the applicant shall pay in respect of each aircraft type applied for, a fee according to weight, as detailed in Table 1 hereof:

Table 1

(i) Does not exceed 5,700 kg	SR 500
(ii) Exceeds 5,700 kg but does not exceed 15,000 kg	SR 1000
(iii) Exceeds 15,000 kg	SR 2000

provided that, where the cost to the Directorate of:

- a. training a Member or employee of the Directorate to act as pilot in command of the type of aircraft to which the course relates;
- b. training a Member or employee of the Directorate to a standard of technical knowledge of that type of aircraft which in the opinion of the Directorate will enable that Member or employee of the Directorate to examine the applicant's proposals for the purposes of the application or to inspect and monitor the type rating training organisation; and
- c. inspecting and monitoring the type rating training organisation:

exceeds the amount specified above, a fee of such amount as may be decided by the Directorate having regard to the expense thereby incurred.

***Approval of Other Training Organisations for Type Ratings***

(12) (a) Upon making an application for the approval or re-approval of a course to conduct ground training only for the type rating, the applicant shall pay in respect of each type applied for a fee of SR 5000;

- (b) Upon making an application for the approval or re-approval of a course of flight training for the type rating only, the applicant shall pay in respect of each type applied for, a fee of SR 2500;

***Authorisation and Approval of Medical Examiners***

(13) Upon making an application for the approval or renewal of an approval to conduct aviation Medical Examinations, the applicant shall pay in respect of each Class applied for, a fee according to Class, as detailed in Table 2 hereof:

Table 2

	Class of Medical	Approval	Renewal
(i)	Class 1 (inclusive of Class 2 and 3)	SR 2500	SR 1500
(ii)	Class 2 (inclusive of Class 3)	SR 1500	SR 1000
(iii)	Class 3 only	SR 1000	SR 500

***Medical Examinations for Personnel Licences***

(14) Upon making an application for a medical examination to be conducted by an Authorised Medical Examiner, the applicant shall pay the total fee appropriate to the Class of medical certificate applied as determined by the designated Examiner.

***Copies of and Amednments to Documents***

- (15) (a) Upon making the application for the issue by the Directorate of a copy or replacement of a document issued under these regulations, the applicant shall pay a fee of SR 200.
- (b) Upon making application for the amendment of the personal particulars included in a licence to act as a flight crew member, other than a change of name consequent upon marriage, the applicant shall pay a fee of SR 100.

**2. Definitions**

(1) For the purpose of this Part of the Schedule:

‘Commuter category’ means a propeller-driven twin-engined aeroplane that has a seating configuration, excluding the pilot seat(s), of nineteen or fewer and a maximum certificated take-off weight of 8618 kg (19 000 lb) or less as defined by the JAA or equivalent certification standards;

‘Directorate’ means the Directorate of Civil Aviation

‘Large Aeroplane category’ means an aeroplane of more than 5700 kg (12,500 pounds) maximum certificated take-off weight, not including the commuter aeroplane category as defined by the JAA or equivalent certification standards.

‘Large rotorcraft category’ means any rotorcraft with a certified maximum take-off weight exceeding 2730 kg (6000 pounds) as defined by the JAA or equivalent certification standards:

‘MTWA’ in relation to an aircraft means the maximum total weight of the aircraft and its contents at which the aircraft may take-off anywhere in the world in the most favourable circumstances in accordance with the Certificate of Airworthiness in force in respect of the aircraft:

‘Normal Category’ means the aeroplane’s certification category including, utility and aerobatic categories that have a seating configuration, excluding the pilot seat(s), of nine or fewer and a maximum certificated take-off weight of 5670 kg (12 500 lb) or less as defined by the JAA or equivalent certification standards:

‘Private Pilot’s Licence’ means a licence of one of the following classes:

Private Pilot’s Licence (Aeroplanes)

Private Pilot’s Licence (Balloons and Airships)

Private Pilot’s Licence (Helicopters and Gyroplanes)

‘Professional pilot’s licence’ means a licence of one of the following classes:

Airline Transport Pilot’s Licence (Aeroplanes)

Airline Transport Pilot’s Licence (Helicopters and Gyroplanes)

Commercial Pilot’s Licence (Aeroplanes)

Commercial Pilot’s Licence (Helicopters and Gyroplanes)

‘renewal’ means the grant of a further specified period of validity for a licence, rating, qualification approval or authorisation (‘the licence etc’) which allows the holder to exercise the privileges thereof for a further specified period where the licence etc is no longer valid at the time the application is received.

‘revalidation’ means the grant of a further specified period of validity for a licence, rating, qualification approval or authorization (‘the licence etc’) which allows the holder to continue to exercise the privileges thereof for a further specified period where the licence etc is valid at the time the application is received.

‘Small rotorcraft category’ means a rotorcraft with a certified maximum take-off weight of 2730 kg (6000 pounds) or less as defined by the JAA or equivalent certification standards;

‘the Order’ means the Air Navigation (Overseas Territories) Order and any reference to a Part or Article of the Order shall, if that Order be amended or revised, be taken to be a reference to the corresponding Part or Article of the Air Navigation Order for the time being in force;

- (2) All other expressions used in this Part of the Schedule shall, unless the context otherwise requires, have the same respective meanings as in the Order.

## **Part B AIRWORTHINESS AND MAINTENANCE FEES**

### **1. Fees**

Fees shall be payable to the Directorate as follows:

#### ***Certificate of Airworthiness – Series***

(1) For the first issue of a Certificate of Airworthiness in respect of a series aircraft, the applicant shall pay:

- (i) in the case of a glider, a fee of SR 1000; or
- (ii) in the case of a balloon a fee of SR 1000; or
- (iii) in the case of a helicopter certified as a Small Rotorcraft, a fee of SR 800 in respect of each 500 kg, or part thereof, of the maximum weight of the aircraft; or
- (iv) in the case of a helicopter certified as a Large Rotorcraft, a fee of SR 1000 for each 500 kg, or part thereof, of the maximum weight of the aircraft; or
- (v) in the case of an aircraft certified as a Normal aircraft, a fee of SR 800 in respect of each 500 kg, or part thereof, of the maximum weight of the aircraft; or
- (vi) in the case of an aircraft certified as a Commuter aircraft, a fee of SR 1500 for each 500 kg, or part thereof, of the maximum weight of the aircraft; or
- (vii) in the case of an aircraft certified as a Large aircraft, a fee of SR 600 in respect of each 500 kg, or part thereof, of the maximum weight of the aircraft.

***Certificate of Airworthiness – Issue following prior revocation***

(2) For a Certificate of Airworthiness in respect of an aircraft where a Certificate of Airworthiness has previously been issued in respect of that aircraft and has been subsequently revoked, the applicant shall pay a fee or fees equivalent to that fee or fees which would be due if that application were an application for the first issue of a Certificate of Airworthiness, as specified in sub-paragraph (1) above.

***Certificate of Airworthiness – Renewal***

- (3) For the renewal of a Certificate of Airworthiness the applicant shall pay:
- a) in the case of a glider, a fee of SR 1000; or
  - b) in the case of a balloon a fee of SR 800; or
  - c) in the case of a helicopter certified as a Small Rotorcraft, a fee of SR 800 in respect of each 500 kg, or part thereof, of the maximum weight of the aircraft; or
  - d) in the case of a helicopter certified as a Large Rotorcraft, a fee of SR 800 for each 500 kg, or part thereof, of the maximum weight of the aircraft; or
  - e) in the case of an aircraft certified as a Normal aircraft, a fee of SR 600 in respect of each 500 kg, or part thereof, of the maximum weight of the aircraft; or
  - f) in the case of an aircraft certified as a Commuter aircraft, a fee of SR 1000 for each 500 kg, or part thereof, of the maximum weight of the aircraft; or
  - g) in the case an aircraft certified as a Large aircraft, a fee of SR 500 in respect of each 600 kg, or part thereof, of the maximum weight of the aircraft.

***Permit for Aircraft to Fly without Certificate of Airworthiness***

(4) In respect of an application for the grant or variation of a permit for an aircraft to fly without there being in force in respect thereof a Certificate of Airworthiness, the applicant shall pay:

- (i) in the case of an aircraft having a maximum weight not exceeding 500 kg, a fee of SR 1000 or, if the total cost of the investigations exceeds that amount, a fee of such amount as may be decided by the Directorate, having regard to the expense incurred by it in making the investigations; or

- (ii) in the case of an aircraft having a maximum weight exceeding 500 kg, but not exceeding 2730 kg, a fee of SR 2500 or, if the total cost of the investigations exceeds that amount, a fee of such amount as may be decided by the Directorate, having regard to the expense incurred by it in making the investigations; or
- (iii) in the case of any other aircraft, a fee of SR 3500 or, if the total cost of the investigations exceeds that amount, a fee of such amount as may be decided by the Directorate, having regard to the expense incurred by it in making the investigations.

***Certificate of Airworthiness – Change of Category***

(5) In respect of an application to change the category of a Certificate of Airworthiness to enable the aircraft to fly for additional purposes, the applicant shall pay a fee of SR 2000.

***Approval in Respect of Aircraft Equipment (excluding Engines) and Modification, Repair etc of such Equipment***

- (6) (a) In respect of an application for the approval, pursuant to any provision of Part III of the Order, of aircraft equipment, including radio apparatus or the manner of its installation (but excluding applications in respect of engines), the applicant shall pay:
  - (i) in the case of equipment, including radio apparatus, installed, or in the opinion of the Directorate primarily intended to be installed, in aircraft certified as a Small Rotorcraft or Normal aircraft, a fee of SR 2500 or, if the total cost of the investigations exceeds that amount, a fee of such amount as may be decided by the Directorate, having regard to the expense incurred by it in making the investigations; or
  - (ii) in the case of any other equipment, including any other radio apparatus, a fee of SR 3500 or, if the total cost of the investigations exceeds that amount, a fee of such amount as may be decided by the Directorate, having regard to the expense incurred by it in making the investigations.
- (b) In respect of an application for the approval, pursuant to any provision of Part III of the Order, of the modification, repair etc of aircraft equipment, including radio apparatus or the manner of its installation (but excluding applications in respect of engines), the applicant shall pay for the investigations required by the Directorate a fee of SR 1000 or such amount as may be decided by the Directorate, having regard to the expense incurred by it in making the investigations.

***Approval in Respect of the Modification, Repair etc of Aircraft (excluding Engines)***



(7) In respect of an application for the approval, pursuant to any provision of Part III of the Order, of the modification, repair etc of aircraft (but excluding applications in respect of engines), the applicant shall pay:

- (a) for the approval of a minor modification, a fee of SR 500;
- (b) for the approval of any other modification, repair etc:
  - (i) in the case of an aircraft certified as a Small Rotorcraft or Normal aircraft, a fee of SR 3000 or, if the total cost of the investigations exceeds that amount, a fee of such amount as may be decided by the Directorate, having regard to the expense incurred by it in making the investigations; or
  - (ii) in the case of any other aircraft, a fee of SR 4000 or, if the total cost of the investigations exceeds that amount, a fee of such amount as may be decided by the Directorate, having regard to the expense incurred by it in making the investigations.

#### ***Variations and Concessions***

(8) In respect of an application for a variation to an Approved maintenance Schedule maintenance period or a Minimum Equipment List repair intervals, a fee of SR 500.

#### ***Approval of Persons***

(9) (a) In respect of an application for the approval of a person for the purposes of any provision of Part III of the Order other than Article 12, or for any variation of the terms of such approval, the applicant shall pay:

- (i) in the case of an approval as an Over hauler, a fee of SR 15000;
  - (ii) in the case of an approval to maintain aeroplanes or rotorcraft certified as Commuter, Large or Large Rotorcraft a fee of SR 15000;
  - (iii) in the case of an approval to maintain aeroplanes or rotorcraft certified as Normal or Small Rotorcraft, a fee of SR 5000;
  - (iv) in the case of any other approval, a fee of SR 5000;
  - (v) in the case of a variation or extension to the approval, a fee of SR 5000.
- (b) The fee for the renewal of the above approvals shall be the same as for the issue of the initial approval.

### ***Certificate of Airworthiness for Export***

(10) In respect of an application for a certificate of Airworthiness for Export in respect of an aircraft, the applicant shall pay:

- (a) in the case of a glider or a balloon, a fee of SR 1000 or, if the total cost of the investigations exceeds that amount, a fee of such amount as may be decided by the Directorate, having regard to the expense incurred by it in making the investigations;
- (b) in the case of a helicopter or a powered lift (tilt rotor) aircraft, a fee of SR 600 per 500 kg, or part thereof, of the maximum weight of the aircraft;
- (c) in the case of an aircraft, other than a glider, a balloon, a helicopter or a powered lift (tilt rotor) aircraft, a fee of SR 600 per 500 kg, or part thereof, of the maximum weight of the aircraft.

### ***Licensing of Aircraft Maintenance Engineers***

(11) (a) Upon making an application for the grant, renewal, variation or validation of a Licence to act as an Aircraft Maintenance Engineer or for the inclusion of a type rating in such a Licence, the applicant shall pay:

- (i) for the grant of a Licence in any category or sub-division of a category, a fee of SR 1000;
  - (ii) for the inclusion of a type rating in a category or sub-division of a category of a Licence, a fee of SR 500;
  - (iii) for the variation of a Licence to include an additional category or sub-division thereof, a fee of SR 300;
  - (iv) for the renewal of a Licence, a fee of SR 800;
  - (v) for the variation of a Licence other than such a variation as falls within subparagraphs (ii) and (iii) above a fee of SR 200;
- (b) For the purpose of sub-paragraph (a) hereof, 'the inclusion of a type rating' means the specification of a type of aircraft or of a type of equipment in relation to any certificate or certificates, which the Licence authorities the holder to issue.

### ***Ground Examinations***

(12) Upon making an application for an examination to be conducted by the Directorate for the inclusion of a type rating therein or for any other purpose, the applicant shall pay:

- (a) for each initial or additional type rating examination, a fee of SR 500.
- (b) for Seychelles Licence revalidation and ICAO Validation or Conversion examinations Aviation Law and Procedures examinations, a fee of SR 500;
- (c) for any other ground examination, a fee of SR 250 per paper;

provided further that if the examination is to be conducted other than at a place specified by the Directorate the applicant shall pay in addition to the fee for that examination a fee of such amount as may be decided by the Directorate having regard to the expense incurred by it.

***Administrative Fees***

- (13) Upon making an application for:
  - (a) an examination paper to be re-marked, the applicant shall pay a fee of SR 200 and the fee shall be refunded if a pass is subsequently awarded as a consequence of an error made by the Directorate;
  - (b) the refund or transfer of fees or when an examination has been re-arranged at the request of the applicant, the applicant shall pay a fee of SR 200;
  - (c) the issue of a duplicate or replacement examination result notification, the applicant shall pay a fee of SR 150.

***Validation of Aircraft Maintenance Engineer Licences***

- (14) (a) Upon making an application for the issue of a certificate of validation of a licence the applicant shall pay a fee of SR 800.
- (b) Upon making an application for the issue of a certificate of validation of a certificate forming part of a licence, the applicant shall pay a fee of SR 200.
- (c) Upon making an application for the renewal of a certificate of validation of a licence the applicant shall pay a fee of SR 400.
- (d) Upon making an application for the renewal of a certificate of validation of a certificate forming part of a licence the applicant shall pay a fee of SR 100.

***Copies of Documents***

(15) Upon application being made for the issue by the Directorate of a copy or replacement document issued under Part III of the Order the applicant shall pay:

- (a) in the case of a copy or replacement of:
  - (i) a Permit to Fly,
  - (ii) a Certificate of Airworthiness,
  - (iii) a Certificate of Approval of a Person other than one issued under Article 12 of the Order,
  - (iv) a Certificate of Approval of Aircraft Radio Installation, or
  - (v) an Aircraft Maintenance Engineer's Licence, a fee of SR 300;
- (b) in the case of a copy or replacement of any other document a fee of SR 150.

***Time at which Fees are to be paid***

(16) Except as otherwise provided in this Regulation, the fees specified in this Regulation shall be payable upon application being made for the certificate, licence, other document or approval, as the case may be:

Provided that where the amount of the fee depends on the expense incurred by the Directorate:

- (a) the Directorate may require that the application be accompanied by payment of an amount up to 10 per cent of the maximum of such fee;
- (b) the fee in respect of investigations made during any month shall be payable at the end of that month, and any amount paid on application shall be deducted from the fee payable at the end of the final month of investigations.

**2. Definitions**

- (1) For the purposes of this Part of the Schedule:

‘Calendar year’ means the period of 12 months beginning with 1 January in any year;

‘Certificate of Airworthiness for Export’ means a Certificate issued by the Directorate certifying that the aircraft to which the Certificate refers has been examined aircraft to which the Certificate refers has been examined and is considered airworthy in accordance with applicable British Civil Airworthiness Requirements and with any special requirements notified by the importing country;

‘Commuter category’ means a propeller-driven twin-engined aeroplane that has a seating configuration, excluding the pilot seat(s), of nineteen or fewer and a maximum certificated take-off weight of 8618 kg (19 000 lb) or less as defined by the JAA or equivalent certification standards;

‘Directorate’ means the Directorate of Civil Aviation;

‘Large Aeroplane category’ means an aeroplane of more than 5700 kg (12,500 pounds) maximum certificated take-off weight, not including the commuter aeroplane category as defined by the JAA or equivalent certification standards;

‘Large rotorcraft category’ means any rotorcraft with a certified maximum take-off weight exceeding 2730 kg (6000 pounds) as defined by the JAA or equivalent certification standards;

‘Maximum weight’ in relation to an aircraft means the maximum total weight of the aircraft and its contents at which the aircraft may take-off anywhere in the world in the most favourable circumstances in accordance with the Certificate of Airworthiness in force in respect of the aircraft or, in relation to an aircraft not having a Certificate of Airworthiness in force in respect thereof, means the maximum weight specified in the application for a Certificate or Permit, as the case may be;

‘Minor modification’ means a modification which, in the opinion of the Directorate, will not require an investigation exceeding one hour;

‘Normal Category’ means the aeroplane’s certification category including, utility and aerobatic categories that have a seating configuration, excluding the pilot seat(s), of nine or fewer and a maximum certificated take-off weight of 5670 kg (12 500 lb) or less as defined by the JAA or equivalent certification standards;

‘Series Aircraft’ means an aircraft, which in the opinion of the Directorate is identical in all matters affecting airworthiness to another aircraft in respect of which a Certificate of Airworthiness has been issued under an Air Navigation Order;

‘Small rotorcraft category’ means a rotorcraft with a certified maximum take-off weight of 2730 kg (6000 pounds) or less as defined by the JAA or equivalent certification standards;

‘the Order’ means the Air Navigation (Overseas Territories) Order and any reference to a Part or Article of the Order shall, if that Order be amended or revised, be taken to be a reference to the corresponding Part or Article of the Air Navigation Order for the time being in force;

(2) All other expressions used in this Part of the Schedule shall, unless the context otherwise requires, have the same respective meanings as in the Order.

**Part C FEES FOR AIR OPERATOR’S CERTIFICATE**

**1. Fees**

Fees shall be payable to the Directorate as follows:

***Fees on Application for the grant of AOC***

(1) When an application is made for the grant of an Air Operator’s Certificate (AOC), the applicant shall pay a fee of the amount specified Table 1 hereof per certification category of the aircraft specified in the application.

Table 1

<b>Certification Category</b>	<b>Fee</b>
Small Rotorcraft	SR 10,000
Large Rotorcraft	SR 20,000
Normal	SR 10,000
Commuter	SR 20,000
Large	SR 60,000

(2) When an application is made for the grant of an Air Operator’s Certificate authorising flights by a balloon, the applicant shall pay fee of SR 1000 or SR 500 for each month of validity applied for in respect of the Certificate, whichever is higher.

***Fees on Application of Variation AOC***

(3) When an application is made for the variation of an Air Operator’s Certificate to specify additional types of aircraft in the Certificate, the applicant shall pay a fee of the amount specified in Table 2 hereof, appropriate to each type within the certification category specified in the application.

Table 2

<b>Certification Category</b>	<b>Fee</b>
Small Rotorcraft	SR 2,000
Large Rotorcraft	SR 3,000
Normal	SR 4,000
Commuter	SR 5,000
Large	SR 6,000

***Fee on Application for renewal of an AOC***

(4) On 1<sup>st</sup> January of each three-year period, or part thereof, during which an Air Operator's Certificate remains in force the holder of the Certificate shall pay a fee of the amount specified in Table 3 hereof appropriate to each type within the certification category specified in the Certificate.

Table 3

<b>Certification Category</b>	<b>Fee</b>
Small Rotorcraft	SR 4,000
Large Rotorcraft	SR 6,000
Normal	SR 8,000
Commuter	SR 16,000
Large	SR 30,000

***New Type of Aircraft-Additional Fee***

(5) Upon an application being made for the grant of an Air Operator's Certificate or for the variation of such a Certificate being in either case an application to specify a type of aircraft in the Certificate where no application to specify a type of aircraft in the Certificate where no application to specify that type of aircraft in an Air Operator's Certificate has previously been granted by the Directorate, the applicant shall pay, in addition to any other fee payable by virtue of this Regulation, a fee of such amount as may be decided by the

Directorate having regard to the expense incurred by it in training a member or employee up to a level to act as pilot in command of that type of aircraft, where the Directorate deems it necessary.

### ***Extended Twin Engine Operation***

(6) When an application is made for the grant of an Approval to conduct Extended Twin Engine Operations, the applicant shall pay in respect of each type of aeroplane applied for, a fee of SR 5000, provided that when an application is made by the holder of such a Permission in respect of a different type of aeroplane, the applicant shall pay, for each type of aeroplane applied for, a fee of SR 1000.

### ***Special Operations***

(7) When an application is made for the grant of an approval for an aircraft to carry out any special operation, the applicant shall pay SR 1500 per aircraft.

### ***Exemptions***

(8) Upon making an application for the grantm variation or renewal of an exemption issued in accordance with Article 87 of the Order in connection to a Public Transport flight, the applicant shall pay a fee of SR 1000.

### ***Copies of Documents***

(9) Upon application being made for the issue by the Authority of a copy or replacement of a document issued under Part II of the Order the applicant shall pay a fee of SR 100.

## **2. Definitions**

For the purpose of this Part of the Schedule:

- (1) 'Air Operator's Certificate' means a Certificate granted pursuant to Article 6 of the Order certifying that the holder of the Certificate is competent to secure that aircraft operated by him on flights for the purpose of public transport are operated safely;

'Commuter category' means a propeller-driven twin-engined aeroplane that has a seating configuration, excluding the pilot seat(s), of nineteen or fewer and a maximum certificates take-off weight of 8618 kg (19 000 lb) or less as defined by the JAA or equivalent certification standards;

'Directorate' means the Directorate of Civil Aviation;



‘Large Aeroplane category’ means an aeroplane of more than 5700 kg (12,500 pounds) maximum certificated take-off weight, not including the commuter aeroplane category as defined by the JAA or equivalent certification standard;

‘Large rotocraft category’ means any rotocraft with a certified maximum take-off weight exceeding 2730 kg (6000 pounds) as defined by the JAA or equivalent certification standards;

‘Maximum total weight authorised’ in relation to an aircraft means the maximum total weight of the aircraft and its contents at which the aircraft may take-off anywhere in the world in the most favourable circumstances in accordance with the Certificate of Airworthiness in force in respect of the aircraft;

‘Normal Category’ means the aeroplane’s certification category including, utility and aerobatic categories that have a seating configuration, excluding the pilot seat(s), of nine or fewer and a maximum certificated take-off weight of 5670 kg (12 500 lb) or less as defined by the JAA or equivalent certification standards;

‘Small rotorcraft category’ means a rotorcraft with a certified maximum take-off weight of 2730 kg (6000 pounds) or less as defined by the JAA or equivalent certification standards;

‘Special Operation’ means any operation such as Reduced Vertical Separation Minima (RVSM), Reduced Navigation Performance (RNP), MNPS, CAT 2/3 operations or any operations the Directorate may classify as special operation;

‘the Order’ means the Air Navigation (Overseas Territories) Order and any reference to a Part or Article of the Order shall, if that Order be amended or revised, be taken to be a reference to the corresponding Part or Article of the Air Navigation Order for the time being in force;

(2) References to periods during which an Air Operator’s Certificate remains in force shall be deemed to include periods during which the Certificate is suspended.

(3) All other expressions used in this Part of the Schedule shall, unless the context otherwise requires, have the same respective meanings as in the Order.

## **Part D FEES FOR AERODROME LICENSING AERODROME**

### **1. Fees**

Fees shall be payable to the Directorate as follows:

***Grant and Renewal of Aerodrome licences***

- (1) When an application is made for the grant or renewal of an aerodrome licence, the applicant shall pay, in the case of an application for a day licence, a fee of the amount specified in column 2 of the Table 1 hereof, and in the case of an application for a day and night licence, a fee of the amount specified in column 3 of the said Table, being in either case a fee appropriate ICAO Classification of aircraft which the applicant expects to use the aerodrome as set out in Column 1 of the said Table:

Table 1

1	2	3
ICAO Classification Code	Fee for Day licence	Fee for Day and Night licence
1	SR 2500	SR 3500
2	SR 3000	SR 4000
3	SR 5500	SR 6500
4	SR 8000	SR 10000

***Grant and Renewal of Heliport licences***

- (1) When an application is made for the grant or renewal of a heliport licence, the applicant shall pay, in the case of an application for a day licence, a fee of the amount specified in column 2 of the Table 2 hereof, and in the case of an application for a day and night licence, a fee of the amount specified in column 3 of the said Table, being in either case a fee appropriate ICAO Classification of rotorcraft which the applicant expects to use the heliport as set out in column 1 of the said Table:

Table 2

1	2	3
ICAO Classification Code	Fee for Day licence	Fee for Day and Night licence
1	SR 1500	SR 2500
2	SR 2000	SR 3000
3	SR 3500	SR 4500

### *Heliport Inspections*

- (3) Upon application for an official inspection of an aerodrome not followed by the grant or the renewal of a licence, the applicant shall pay a fee of SR 250.

### *Copies of documents*

- (4) When an application is made for the issue by the Directorate of a copy or replacement of a document issued under Part IX of the Order, the applicant shall pay a fee of SR 100.

## **2. Definitions**

- (1) For the purpose of this Part of the Schedule:

‘Day and Night Licence’ means an aerodrome licence authorising the use of the aerodrome to which it relates by aircraft for the purpose of public transport of passengers or for the purpose of instruction in flying at any time;

‘Day Licence’ means an aerodrome licence authorising the use of the aerodrome to which it relates by aircraft flying for the purpose of public transport of passengers or for the purpose of instruction in flying during the period from 2 an hour before sunrise until 2 an hour after sunset in any day;

‘Directorate’ means the Directorate of Civil Aviation;

‘Heliport Licence’ means a licence granted pursuant to Article 68 of the Order intended for use by helicopters;

‘ICAO Classification code’ means aircraft or rotorcraft as classified in accordance with ICAO Annex 14;

‘the Order’ means the Air navigation (Overseas Territories) Order and any reference to a Part or Article of the Order shall, if that Order be amended or revised, be taken to be a reference to the corresponding Part or Article of the Air Navigation Order for the time being in force.

- (2) All other expressions used in this Part of the Schedule shall, unless the context otherwise requires, have the same respective meanings as in the Order.

## **PART E FEES FOR AIRCRAFT REGISTRATION**

### **1. Fees**

Fees shall be payable to the Directorate as follows:

#### ***Certificate of Registration of an Aircraft***

- (1) Upon making an application for the grant of a Certificate of Registration of an aircraft, other than such an application as is referred to in sub-paragraph (3) below, the applicant shall pay a fee in accordance with Table 1 hereof:

Table 1

Aircraft in respect of which application is made	Fee Payable
Balloon	SR 500
Un-powered glider	SR 500
Any other aircraft having a maximum weight	
Not exceeding 5700 kg	SR 1000
Exceeding 5700 kg	SR 1500

- (2) Upon making an application to reserve an out of sequence registration mark for an aircraft, the applicant shall pay SR 500 for each six month period of reservation or part thereof.

- (3) Upon making an application for the grant of a Certificate of Registration of an aircraft specifying an out of sequence registration mark, the applicant shall pay the appropriate fee payable under sub-paragraph (1) above plus SR 1000:

#### ***Copies of Documents***

(4) Upon making an application for the issue by the Directorate of a copy of any document issued under Article 4 of the Order, the applicant shall pay a fee of SR 100.

## **2. Definitions**

(1) For the purposes of this Part of the Schedule:

‘Directorate’ means the Directorate of Civil Aviation;

‘Maximum weight’ in relation to an aircraft means in the case of an aircraft in respect of which a certificate of airworthiness is or has been in force the maximum total weight authorised in the certificate of airworthiness in force, in respect of the aircraft or, if no such certificate is in force, the certificate of airworthiness last in force in respect of that aircraft. In any other case ‘maximum weight’ means the maximum total weight authorised of the prototype or modification thereof to which the aircraft in the opinion of the Directorate conforms.

‘the Order’ means the Air Navigation (Overseas Territories) Order and any reference to a Part or Article of the Order shall, if that Order be amended or revised, be taken to be a reference to the corresponding Part or Article of the Air Navigation Order for the time being in force.

(2) All other expressions used in this Part of the Schedule, shall unless the context otherwise requires, have the same respective meanings as in the Air Navigation Order.

## **PART F ADDITIONAL FEES**

### **1. Fees**

Fees shall be payable to the Directorate as follows:

#### ***Additional Fee where Functions are Performed Abroad***

(1) When an application is made for the Directorate to perform a function in respect of which a fee is specified in this Regulation as a result of which the Directorate has to travel outside the Seychelles, the applicant shall pay, in addition to the appropriate fee specified in his Regulation, a fee equal to the additional cost thereby incurred during which time such member of employee or any other person appointed to act on behalf of the Directorate is absent from the country in which he is normally stationed.

#### ***Assesment of Manuals***

(2) For the assessment of manuals required to be submitted for the issue or continuation of an Air Operator’s Certificate or an Approved Maintenance

Organisation, including the assessment of amendments and subsequent issues a fee of SR 100 per man/hour.

---

**ARTICLES 67, 71 AND 89 OF AIR NAVIGATION (OVERSEAS TERRITORIES) ORDER**

S.I.38 of 1976.  
S.I.50/1978.  
S.I.23/1979.  
S.I.28/1979.  
S.I. 4/1981.  
S.I. 3/1986.  
S.I.64/1987.  
S.I. 3/1991.

**THE SEYCHELLES INTERNATIONAL AIRPORT NOTIFICATION, 1976.\***

1. This Notification may be cited as the Seychelles International Airport Notification.

2. In this Notification -

"Director" means the Director of Civil Aviation;

"flying club" means a flying club recognised as such by the Director;

"the aerodrome" means the Seychelles International Airport.

3. The aerodrome is hereby notified as an aerodrome available for take-off and landing by aircraft engaged on flights for the purpose of the public transport of passengers or for instruction in flying.

4. The charges and fees for the use of the aerodrome shall be as set out in the Schedule hereto.

5. Unless some alternative arrangement has been made with the Director, all single landing charges and all parking fees due and payable in respect of an aircraft shall be paid by or on behalf of the operator of the aircraft before the aircraft leaves the aerodrome, and all annual monthly landing charges shall be paid in advance, and the Director may refuse clearance to the aircraft until such charges and fees have been paid.

**SCHEDULE**

**LANDING CHARGES**

1. Subject to paragraphs 2 to 7 the charge for the landing of an aircraft at the aerodrome shall be -

---

Note: \*This notification made under Article 60 of the Colonial Air Navigation Orders 1961 to 1972 were kept in force under the Air Navigation (Overseas Territories) Order, 1976 notwithstanding the repeal by it of the Colonial Air Navigation Orders, 1961 - 1972.

Maximum ramp weight of aircraft		Charge per 1000 kg or part of 1000kg maximum ramp weight (R)
Exceeding kg (R)	Not exceeding kg (R)	
-	10,000	22.00
10,000	60,000	29.00
60,000	110,000	33.00
110,000	210,000	36.50
210,000	-	41.50

**2** (1) Subject to sub-paragraph (2) where the landing or take-off of the aircraft occurs between 19.00 and 05.30 hours there shall be added to the charge payable under paragraph 1 a surcharge of 40% of that charge.

(2) An aircraft arriving from, or leaving for, any place outside Seychelles shall be subject to a minimum charge of R.550, in the case where the charge calculated in accordance with paragraph 1 is less than R550, or R.770, in the case where the charge calculated in accordance with paragraph 1A(1) is less than R770.

**3.** Where an aircraft is landed for the sole purpose of training or checking flying personnel by prior arrangement with the Director, the charge for such landing is one-third of the appropriate charge specified in paragraph 1 above;

**4.** Landing charges for aircraft not exceeding a weight of 2000 kg operated by flying clubs or privately owned and used solely for private or private business purposes or for instructional or practice flying, and not being used for hire or reward, shall be one-half of the appropriate charge specified in paragraphs 1 and 3 above:

Provided that the Director may, at his discretion, approve an annual or monthly landing charge for landings by such aircraft and such annual or monthly landing charge shall be in lieu of single charges and shall cover all landings by such aircraft within the period for which the annual or monthly charge is paid, and shall be calculated, in the case of an annual charge at R.1000.000.

**5.** Landing charges for helicopters shall be at one-half of the rate applicable to fixed-wing aircraft.



6. No charge is payable in respect of a landing at the aerodrome -
- (a) of an aircraft in respect of which the Director has given special landing permission, provided the aircraft is being used for the purpose specified on the giving of the permission, and is landed in accordance with any directions given by the Director;
  - (b) of an aircraft that is carrying out a test flight with the prior approval of the Director;
  - (c) of aircraft engaged in search and rescue operations;

7. For the purposes of calculating the charge for the landing of an aircraft, the maximum ramp weight of the aircraft is that specified in its Certificate of Airworthiness or the associated Flight Manual, taking no account of any restriction or limiting factor that may be applicable in particular circumstances.

#### PARKING FEES

8 (1) Subject to sub-paragraph 92), the charge for parking an aircraft in the open on a parking area provided for that purpose shall be R.7.50 per 45m or part of 45m of parking area occupied by the aircraft for each 24 hours or part of 24 hours during which the aircraft is parked (the period being calculated from the start of parking regardless of sub-paragraph 2(2)(b))

- (2) No parking charge shall be payable in respect of an aircraft -
- (a) for which in terms of paragraph 6 no landing charge is payable of;
  - (b) which is parked for a continuous period of less than 6 hours.

---

Articles 67, 71 and 89 of the Air Navigation (Overseas) Territories Order

S.I.66 of 1988.  
S.I.42 of 1994.

### **Praslin Aerodrome (Notification, Charges and Fees) Regulations**

*[1st January, 1989]*

1 These Regulations may be cited as the Praslin Aerodrome (Notification, Charges and Fees) Regulations.

2 In these Regulations -

"Director General" means the Director General of Civil Aviation;

"flying club" means a flying club recognised as such by the Director General;

"the aerodrome" means Praslin Aerodrome.

**3** The aerodrome is hereby notified as an aerodrome available for take-off and landing of aircraft engaged on flights for the purpose of the public transport of passengers or of instruction in flying.

**4** There shall be paid for the use of the aerodrome the charges and fees set out in the Schedule.

**5** (1) Unless some alternative arrangement has been made with the Director General, all single landing charges and all parking fees due and payable in respect of an aircraft shall be paid by or on behalf of the operator of the aircraft before the aircraft leaves the aerodrome, and all annual and monthly landing charges shall be paid in advance, and the Director General may refuse clearance to the aircraft until such charges and fees have been paid.

(2) The passenger service fee shall be paid by the passenger to the person or agency issuing the passenger ticket who shall within 30 days of the issue of the ticket remit the fee to the Director General.

## SCHEDULE

### LANDING CHARGES

**1.** Subject to paragraphs 2-7, the charges for the landing of an aircraft at the aerodrome shall be R.22/- for each 1,000 kg or part thereof of the weight of the aircraft.

**2.** Where an aircraft is landed for the sole purpose of training or checking flying personnel, by prior arrangement with the Director General, the charge for such a landing is one-third of the appropriate charge specified in paragraph 1.

**3.** (1) When an aircraft is operating for hire or reward on internal flights within Seychelles the Director General may, at his discretion approve an annual or monthly landing charge for landings by that aircraft and, subject to subparagraph (2), such annual or monthly landing charge shall be in lieu of single landing charges and shall cover all landings by that aircraft within the period for which the annual or monthly charge is paid. The amount of such charge shall be -

- (a) in the case of an annual charge, fifty times the cost of a single landing charge;
- (b) in the case of a monthly charge, six times the cost of a single landing charge.

(2) The annual or monthly landing charge paid under subparagraph (1) in respect of an aircraft shall not cover a landing of that aircraft in respect of a flight which

originates or terminates outside Seychelles, and there shall be paid for each such landing a single landing charge.

**4.** Landing charges for aircraft not exceeding a weight of 2000 kg operated by flying clubs or privately owned and used solely for private or private business purposes or for instructional or practice flying, and not being used for hire or reward shall be one-half of the appropriate charge specified in paragraphs 1 and 2:

Provided that the Director General may, at his discretion, approve an annual or monthly landing charge for landing by such aircraft and such annual or monthly landing charge shall be in lieu of single charges and shall cover all landings by such aircraft within the period for which the annual or monthly charge is paid, and shall be calculated as follows -

- (a) in the case of an annual charge, R.1000/-;
- (b) in the case of a monthly charge, R.100/-.

**5.** Landing charges for helicopters shall be at one-half of the rate applicable to fixed-wing aircraft.

**6.** No charge is payable in respect of a landing at the aerodrome -

- (a) of an aircraft in respect of which the Director General has given special landing permission, provided the aircraft is being used for the purpose specified on the giving of the permission, and is landed in accordance with any directions given by the Director General;
- (b) of an aircraft that is carrying out a test flight with the prior approval of the Director General;
- (c) of an aircraft engaged in search and rescue operation;
- (d) of any other aircraft or class of aircraft exempted by the Director General.

**7.** Where the landing or take-off of aircraft occurs between 1900 hours and 0530 hours there shall be added to the charge payable under paragraph 1, a surcharge of 40% of that charge.

**8.** For the purpose of calculating the charge for the landing of an aircraft, the weight of the aircraft is the maximum permissible weight specified for the aircraft in the Certificate of Airworthiness or the associated Flight Manual, taking no account of any restriction or limiting factor that may be applicable in particular circumstances.

#### *PARKING FEES*

**9.** (1) When an aircraft is parked in the open of an area prepared and provided for that purpose and is so parked for a period of more than six continuous hours, there

shall be paid a parking fee for each day or part thereof during which the aircraft is parked, calculated at the daily rate of R.7.50 for each forty five square meters of space or part thereof occupied by the aircraft.

(2) For the purpose of assessing the fees payable under subparagraph (1), the first six hours specified in that subparagraph during which the aircraft is parked shall be included in the period of parking.

(3) Notwithstanding the foregoing provisions of this paragraph, parking fees shall not be payable in respect of an aircraft for which landing charges are not required to be paid.

**10.** (1) Subject to subparagraph (2), there shall be charged in respect of every passenger embarking on a domestic flight at the aerodrome a passenger service fee of R3.

(2) Subparagraph (1) shall not apply to a passenger under 2 years of age.

(3) In this paragraph, “domestic flight” means a flight in a public transport aircraft departing from the aerodrome.

---

Paragraph 3 of the Schedule

S.I. 55 of 1971.  
S.I. 95 of 1975.  
S.I. 72 of 1976.

**THE CIVIL AVIATION (INVESTIGATION OF ACCIDENTS) REGULATIONS**

*[21st June, 1971]*

ARRANGEMENT OF REGULATIONS

1. Citation.
2. Interpretation.
3. Application of regulations.
4. Purpose of accident investigation.
5. Accident to be notified.
6. Contents of notice.

7. Removal of damaged aircraft.
8. Inspectors of accidents.
9. Powers of inspectors.
10. Inspector's investigation.
11. Notice and representations.
12. Review Board.
13. Hearing and review.
14. Publication of reports.
15. Re-opening of investigation or review.
16. Public inquiries.
17. Rehearing of public inquiries.
18. General.
19. Obstruction.

---

1. These regulations may be cited as the Civil Aviation (Investigation of Accidents) Regulations.

2. (1) In these Regulations, unless the context otherwise requires -

"commander" in relation to an aircraft means the member of the crew designated as commander of that aircraft by the operator thereof, or failing such a person, the person who is for the time being the pilot in command of the aircraft;

"Director" means the Director General of Civil Aviation;

"Inspector" means a person appointed as an Inspector of Accidents under these regulations;

"operator" in relation to an aircraft means the person for the time being having the management of that aircraft;

"owner" means, where an aircraft is registered, the registered owner;

"pilot in command" in relation to an aircraft means a person who for the time being is in charge of the piloting of the aircraft without being under the direction of any other pilot in the aircraft;

"substantial damage" includes any damage or structural failure which adversely affects the structural strength, performance or flight characteristics of the aircraft and which would normally require the major repair or replacement of the affected component.

(2) The Interpretation and General Provisions Act shall apply with the necessary adaptations for the purpose of interpreting these regulations and otherwise in relation thereto as it applies for the purposes of interpreting, and in relation to, an Act.

**3** These regulations relate only to civil aviation and shall apply to accidents arising out of or in the course of air navigation which occur to civil aircraft in or over Seychelles, or elsewhere to civil aircraft registered in Seychelles.

**4** The main purpose of investigating accidents under these regulations shall be to determine the circumstances and causes of the accident with a view to avoiding accidents in the future, rather than to ascribe blame to any person.

**5** An accident shall be notified in accordance with the provisions of regulation 6 if, between the time when any person boards an aircraft with the intention of flight and such time as all persons have disembarked therefrom -

- (a) any person suffers death or serious injury while in or upon the aircraft or by direct contact with the aircraft or anything attached thereto; or
- (b) the aircraft receives substantial damage.

**6** (1) Where an accident occurs of which notification is required to be given under regulation 5, the commander of the aircraft involved at the time of the accident or if he be killed or incapacitated then the operator of the aircraft shall forthwith give notice thereof to the Director by the quickest means of communication available and in the case of an accident occurring in or over Seychelles, shall also notify forthwith the local police authorities of the accident and of the place where it occurred.

(2) The notice to the Director referred to in paragraph (1) of this regulation shall commence with the identifying abbreviation ACCID, and shall state as far as possible -

- (a) the type, model and the nationality and registration marks of the aircraft;
- (b) the name of the owner, operator and hirer, if any of the aircraft;
- (c) the name of the commander of the aircraft;

- (d) the date and Greenwich mean time of the accident;
- (e) the last point of departure and the next point of intended landing of the aircraft;
- (f) the position of the aircraft with reference to some easily defined geographical point;
- (g)
  - (i) the number of persons on board the aircraft at the time of the accident,
  - (ii) the number of those persons killed as a result of the accident,
  - (iii) the number of those persons seriously injured as the result of the accident,
  - (iv) the number of persons killed or seriously injured elsewhere than on the aircraft;
- (h) the nature of the accident and brief particulars of damage to the aircraft as far as is known.

(3) Where an accident to which these regulations apply occurs, whether in or over Seychelles or elsewhere, the owner, operator, commander or hirer of the aircraft shall, if so required by notice in writing from the Director, send to the Director within such time as may be specified in the notice, such information as is in his possession or control with respect to the accident in such form as the Director may require.

**7** (1) Where an accident occurs in or over Seychelles, or which notification is required to be given under regulation 5, no person other than an authorised person shall have access to the aircraft involved in the accident and the aircraft shall not except under the authority of the Director be removed or otherwise interfered with:

Provided that -

- (i) the aircraft may be removed or interfered with so far as may be necessary for the purpose of extricating persons or animals involved, removing any mails carried by the aircraft, preventing destruction by fire or other cause, or preventing any danger or obstruction to the public or to air navigation or to other transport;
- (ii) goods or passengers' baggage may be removed from the aircraft under the supervision of a police officer but, if the aircraft has come from a place outside Seychelles, shall not be removed from the vicinity of the aircraft except on clearance by or with the consent of an officer of Customs;

- (iii) if an aircraft is wrecked on the water, the aircraft or any contents thereof may be removed to such extent as may be necessary for bringing it or them to a place of safety.

(2) In this regulation the expression "authorised person" means any person authorised by the Director either generally or specially to have access to any aircraft involved in an accident and includes any police officer or any officer of Customs.

**8** (1) For the purpose of carrying out investigation into the circumstances and causes of accidents to which these regulations apply the President shall appoint one or more persons to be an Inspector or Inspectors of Accidents.

(2) In the case of any accident, whether or not such accident is one of which notification is required to be given under regulation 5, an Inspector shall determine whether or not an investigation is to be carried out.

(3) Without prejudice to the power of an Inspector to seek such advice or assistance as he may deem necessary in making an investigation, the Director may at the request of an Inspector appoint persons to assist the Inspector in a particular investigation and such persons shall for the purpose of so doing have such of the powers of an Inspector under these regulations as may be specified in their appointment.

**9** For the purpose of the investigation of any accident to which these regulations apply, an Inspector shall have power -

- (a) by summons under his hand to call before him and examine all such persons as he thinks fit, to require such persons to answer any question or furnish any information or produce any books, papers, documents and articles which the Inspector may consider relevant, and to retain any such books, papers, documents and articles until the completion of the investigation or any inquiry held pursuant to regulation 16 of these regulations;
- (b) to take statements from all such persons as he thinks fit and to require any such person to make and sign a declaration of the truth of the statement made by him;
- (c) to have access to and examine any aircraft involved in the accident and the place where the accident occurred, and for that purpose to require any such aircraft or any part or equipment thereof to be preserved unaltered pending examination;
- (d) to examine, remove, test, take measures for the preservation of, or otherwise deal with, the aircraft or any part thereof or anything contained therein;



- (e) to enter and inspect any place or building the entry or inspection whereof appears to the Inspector to be requisite for the purposes of the investigation or of any inquiry held as aforesaid;
- (f) to take measures for the preservation of evidence.

**10** (1) Public notice that an investigation by an Inspector is taking place shall be given in such manner as the Inspector may think fit and shall invite any persons who desire to make representations concerning the circumstances or causes of the accident to do so in writing within a time to be specified in the notice.

(2) An Inspector's investigation shall be held in private.

(3) Where it appears to the Inspector that in order to resolve any conflict of evidence or that for any other reason it is expedient so to do, he may permit any person to appear before him and to call evidence and examine witnesses.

(4) Every person summoned by the Inspector as a witness in accordance with these regulations shall be allowed such expenses as the Director, with the approval of the Minister for Finance may determine.

(5) Subject to the provisions of regulation 11, upon completion of an Inspector's investigation the Inspector shall make a report to the Director. The report shall state the circumstances of the accident and conclusions as to the cause, together with any observations and recommendations which the person making the report thinks fit to make with a view to the preservation of life and the avoidance of similar accidents in the future.

**11** (1) No report shall be made to the Director under regulation 10(5) in respect of an accident until the Inspector has -

- (a) served a notice under this regulation upon the operator and commander of the aircraft involved in that accident and on any other person, including the Director, whose reputation is, in the Inspector's opinion, likely to be adversely affected by the report, and
- (b) considered any representations which may be made to him in accordance with subregulation (3) by or on behalf of the persons served with such notice.

(2) The notice referred to in subregulation (1) shall include particulars of any of those proposed findings and conclusions as to the circumstances and causes of the accident which may affect the person on whom the notice is served.

(3) Any representations made pursuant to subregulation (1) shall be in writing and shall be served on the Inspector within 28 days of service of the notice referred to in that paragraph.

(4) Any person who has been served with a notice pursuant to subregulation (1) shall be served with a copy of the report made to the Director.

**12** (1) Any person, other than the Director, who has been served with a notice pursuant to regulation 11(1) may, at any time before the expiration of the period of 21 days from the day on which he has been served with a copy of the report to the Director, serve on the Director written notice (hereinafter called "the notice of review") that he wishes those findings and conclusions in the report from which it appears that any degree of blame for the accident may be attributed to him, or to any deceased person whose executor, administrator or other personal representative he is, to be reviewed by a Review Board.

(2) The Review Board shall consist of a person to be appointed for the purpose by the Chief Justice, sitting with such technical Assessors, if any, as may be so appointed.

(3) The notice of review shall state concisely the grounds on which the findings and conclusions in the report are challenged. A copy of the notice of review shall, at the same time as it is served on the Director, be served on the Attorney General and the person requesting the review shall inform the Attorney General whether or not he proposes to be legally represented at the hearing of the review and of the name and address of the barrister or attorney, if any, acting for him, or of any other person who will be representing him at the review.

(4) A copy of the notice of review shall also be served by the person requesting the review on each of the persons on whom the Inspector has served a notice under regulation 11; and for this purpose the person requesting the review may require the Inspector to furnish him with the names and addresses of those persons.

(5) In a case where the Director, having made representations pursuant to regulation 11(1), wishes those findings and conclusions in the report from which it appears that any degree of blame for the accident may be attributed to the Director to be reviewed by a Review Board appointed under this regulation, the Director shall, before the expiration of the period of 14 days from the day of receipt by the Director of the Inspector's report, serve a notice of review on the Attorney General. The Director shall serve a copy of the notice on each of the persons on whom the Inspector has served a notice under regulation 11.

**13** (1) Where notice of review has been served under regulation 12, the Director shall forthwith entrust the review to the appointed Review Board.

(2) The Director shall serve on the person requesting the review and all persons on whom the Inspector has served a notice under regulation 11, not less than 21 days' notice of the date, time and place of the hearing of the review (hereinafter called "the notice of hearing").

(3) The hearing shall be in public unless the Review Board determines, in relation to the whole or part of the review, that it is to be held in private in the interest of justice or in the public interest.

(4) The Review Board shall be assisted by the Attorney General, or by a barrister or attorney instructed by him, who shall present any evidence required by the Review Board and may examine any witnesses giving evidence at the review.

(5) The person requesting the review shall be heard by the Review Board and shall have the right to produce witnesses and examine any other witnesses giving evidence at the review.

(6) Before the date fixed for the hearing of the review the Review Board shall hold a preliminary meeting at which any directions may be given or any preliminary or interlocutory order as to the procedure may be made. Notice of the date, time and place of the preliminary meeting shall be given by the Attorney General to all persons on whom the notice of hearing has been served and any person intending to make any application to the Review Board at the meeting shall give notice thereof to the Attorney General.

(7) Any person, including the Director, who in the opinion of the Review Board may be affected by the review may be granted leave to appear and to produce witnesses and examine any other witnesses giving evidence at the review. Any application for such leave may be made to the Review Board at the preliminary meeting.

(8) In any proceedings of the Review Board the person requesting the review and any other person appearing pursuant to leave granted under subregulation (7) may appear in person or be represented by any other person whom he may have authorised to represent him.

(9) In addition to all the powers of an Inspector under these regulations, the Review Board may administer the oath to any witness, or require any witness to make and sign a declaration of the truth of the statements made by him in his examination.

(10) Every person summoned by the Review Board as a witness in accordance with this regulation shall be allowed such expenses as the Director, with the approval of the Minister for Finance, may determine.

(11) (a) The Review Board may, if it thinks fit, order any person who appears or is represented as mentioned in subregulation (8) to pay in respect of the costs of the Review Board such sum as may be specified in the order, or the taxed amount of those costs or such part thereof as may be so specified, and, without prejudice to the generality of the foregoing, the Review Board shall, in determining whether to make an order as to costs against any person, have regard to whether or not that person took advantage of such

opportunities as were open to him to make representations under regulation 11.

- (b) Any costs required by an order under the foregoing sub-paragraph to be taxed shall be taxed by the Registrar of the Supreme Court.
- (c) Any sum payable by virtue of an order under paragraph (a) shall, if the Supreme Court so orders, be recoverable by execution issued from the Supreme Court or otherwise as if payable under an order of that court.

(12) Upon completion of the review the Review Board shall make a report to the Director containing a summary of the proceedings at the hearing and either confirming or rejecting in whole or in part those findings and conclusions of the Inspector which were the subject of the review, together with its reasons therefor, and the Director shall serve a copy of the report on all persons who appeared or were represented before the Review Board.

**14** The Director shall, unless in his opinion there are good reasons to the contrary, cause the Inspector's report and, where a Review Board has been held, the report of the Review Board, to be made public wholly or in part in such manner as he thinks fit:

Provided that -

- (i) in any case where notice has been given under regulation 11(1), the Inspector's report shall not be published before the expiry of the time for service of a notice of review under regulation 12(1);
- (ii) in any case where a Review Board is held, the Inspector's report shall not be published until the completion of the review.

**15** (1) In the case of any investigation by an Inspector which has not been the subject of a review and in the case of a review, the Director may cause the investigation to be reopened or, as the case may be, may direct the review to be reheard, in both cases either generally or as to any part thereof, and the Director shall do so -

- (a) if new and important evidence has been discovered, or
- (b) if for any other reason there is in his opinion ground for suspecting that a miscarriage of justice has occurred.

(2) If the Director directs any review to be reheard, the Chief Justice may direct that the review shall be reheard either by the Review Board by whom it was heard in the first instance or by some other Review Board appointed by him to hold the rehearing.

(3) Any investigation reopened or review reheard shall be subject to and conducted in accordance with the provisions of these regulations relating to an Inspector's investigation or review thereof as the case may be.

**16** (1) Where it appears to the Director that it is expedient in the public interest to hold a Public Inquiry into the circumstances and causes of, or into any particular matter relating to, an accident to which these regulations apply, he may direct that a Public Inquiry be held by a Commissioner appointed by the Chief Justice. In any such case any investigation by an Inspector relating to the accident or to the particular matter, as the case may be, shall be discontinued except for the purpose of rendering assistance as required by subregulation (3).

(2) The Commissioner (hereinafter called "the Court") shall be a barrister or attorney of not less than five years standing and shall be assisted by not less than two Assessors possessing aeronautical, engineering or other special skill or knowledge. The assessors shall be appointed by the Chief Justice.

(3) Where the Director has directed a Public Inquiry to be held, he shall remit the case to the Attorney General, and thereafter the preparation and presentation of the case shall be conducted by the Attorney General or by a barrister or attorney instructed by him; the Inspector shall render such assistance to the Court and to the Attorney General as is in his power.

(4) When a Public Inquiry has been ordered the Attorney General may cause a notice, to be called a notice of inquiry, to be served upon the owner, operator, hirer and commander of any aircraft involved in the accident, as well as upon any person who in his opinion ought to be served with such notice. The notice shall contain a statement of the questions which on the information then in the possession of the Attorney General he intends to raise on the hearing of the inquiry and he may by subsequent notice amend, add to, or omit any of the questions specified in the notice of inquiry.

(5) The Attorney General, the owner, the operator, the hirer, the commander and any other person upon whom a notice of inquiry has been served, shall be deemed to be parties to the proceedings.

(6) Any other person, including the Director, may, by leave of the Court appear, and any person who so appears shall thereupon become a party to the proceedings. Any application for such leave may be made to the Court at a preliminary meeting.

(7) At any time before the date appointed for holding the inquiry, the Court may hold a preliminary meeting at which any directions may be given or any preliminary or interlocutory order as to the procedure may be made. Any persons making any application to the Court at the preliminary meeting shall give notice thereof to the Attorney General.

- (8) (a) The Court shall have, for the purposes of the inquiry, all the powers of a Magistrate's Court, and without prejudice to those powers, the Court may -
- (i) enter and inspect, or authorise any person to enter and inspect, any place or building entry or inspection whereof appears to the Court requisite for the purposes of the inquiry;
  - (ii) by summons require the attendance as witnesses of all such persons as the Court thinks fit to call and examine, and require such persons to answer any questions or furnish any information or produce any books, papers, documents and articles which the Court may consider relevant;
  - (iii) administer the oath to any such witness, or require any witness to make and sign a declaration of the truth of the statement made by him in his examination;
- (b) The Assessors shall have the same power of entry and inspection as the Court.

(9) Affidavits and statutory declarations may, by permission of the Court and saving all just exceptions, be used as evidence at the hearing.

(10) At the time and place appointed for holding the inquiry the Court may proceed with the inquiry whether the parties, upon whom a notice of inquiry has been served, or any of them are present or not.

(11) The Court shall hold the inquiry in open Court save to the extent to which the Court is of opinion that in the interest of justice or in the public interest any part of the evidence, or any argument relating thereto, should be heard in camera.

(12) The proceedings on the inquiry shall commence with the production and examination of witnesses on behalf of the Attorney General. These witnesses, after being examined on behalf of the Attorney General, may be cross-examined by the parties in such order as the Court may direct, and may then be re-examined on behalf of the Attorney General. Questions asked and documents tendered as evidence in the course of the examination of these witnesses shall not be open to objection merely on the ground that they do or may raise questions which are not contained in or which vary from the question specified in the notice of inquiry or subsequent notices referred to in subregulation (4).

(13) When the examination of the witnesses produced on behalf of the Attorney General has been concluded, the Attorney General or the person appearing on his behalf shall state the questions in reference to the accident and to the conduct of persons connected with the accident upon which the opinion of the Court is desired. In framing the questions for the opinion of the Court, the Attorney General or such person shall make such modifications in, additions to or omissions from the questions in the notice

of inquiry or subsequent notices referred to in subregulation (4) as, having regard to the evidence which has been given, the Attorney General or such person or the Court may think fit.

(14) After the questions for the opinion of the Court have been stated, the Court shall proceed to hear the parties to the proceedings and determine the questions so stated. Each party to the proceedings shall be entitled to address the Court and produce witnesses or recall any of the witnesses who have already been examined for further examination and generally adduce evidence. The parties shall be heard and their witnesses examined, cross-examined and re-examined in such order as the Court shall direct. Further witnesses may also be produced and examined on behalf of the Attorney General and may be cross-examined by the parties and re-examined on behalf of the Attorney General.

(15) When the whole of the evidence in relation to the questions for the opinion of the Court has been concluded any of the parties who desires so to do may address the Court upon the evidence and the Court may be addressed in reply upon the whole case on behalf of the Attorney General.

(16) The Court may adjourn the inquiry from time to time and from place to place, and where an adjournment is asked for by any party to the inquiry the Court may impose such terms as to payment of costs or otherwise as it may think just as a condition of granting the adjournment.

(17) The Court shall make a report to the Director stating fully the circumstances of the case and the opinion of the Court touching the causes of the accident or on the particular matter referred to the Court and adding any observations and recommendations which the Court thinks fit to make with a view to the preservation of life and the avoidance of similar accidents in future.

(18) Each Assessor shall either sign the report with or without reservations, or state in writing his dissent therefrom and his reasons for such dissent, and such reservations or dissent and reasons (if any) shall be forwarded to the Director with the report. The Director shall unless in his opinion there are good reasons to the contrary cause any such report and reservations or dissent and reasons (if any) to be made public wholly or in part in such a manner as he thinks fit.

(19) Every person attending as a witness before the Court shall be allowed such expenses as would be allowed to a witness attending before the Supreme Court, and in case of dispute as to the amount to be allowed, the same shall be referred by the Court to the Registrar of the Supreme Court who, on request signed by the Court, shall ascertain and certify the proper amount of the expenses; provided that in the case of any party to the proceedings or of any person in the employment of such a party, any such expenses may be disallowed if the Court in its discretion so directs.

**17** (1) The Director may, in any case where a Public Inquiry has been held, direct a rehearing of the inquiry either generally or as to any part thereof and shall do so -

- (a) if new and important evidence has been discovered, or
- (b) if for any other reason there is in his opinion ground for suspecting that a miscarriage of justice has occurred.

(2) If the Director directs any inquiry to be reheard, the Chief Justice may direct that the inquiry shall be re-heard either by the Court by whom the inquiry was heard in the first instance or by some other person appointed by him to hold the rehearing.

(3) Any rehearing shall be subject to, and conducted in accordance with, the provisions of these regulations relating to the holding of Public Inquiries.

**18** (1) Where an accident has occurred in or over Seychelles to an aircraft registered in any country or territory other than Seychelles, the Director may authorise an investigator appointed by the duly competent authority of that other country or territory to carry out an investigation in Seychelles and in that event the Director shall, so far as he is able, facilitate inquiries by the investigator so appointed.

(2) In any investigation by an Inspector or any Public Inquiry an accredited representative of the country or territory in which the aircraft is registered, or of any country or territory in which the aircraft was manufactured or which has, on request, furnished information in connection with the accident, may take part in the investigation or in the Inquiry as the case may be, that is to say he shall be permitted to visit the scene of the accident, examine the wreckage, question witnesses, receive copies of all pertinent documents (saving all just exceptions), have access to all relevant evidence and make submissions; and he may be accompanied by such technical and other advisers as may be considered necessary by the authorities of the country or territory by which he is appointed.

(3) The Inspector, in the case of the period of 28 days prescribed in regulation 11(3), and the Director, in the case of the period of 21 days prescribed in regulation 12(1), shall have power to extend the said period, and this power shall be exercisable notwithstanding that the period so prescribed has expired.

**19** (1) A person shall not obstruct or impede the Court or the Review Board or an Inspector or an Assessor or any person acting under the authority of the Director in the exercise of any powers or duties under these regulations.

(2) A person shall not without reasonable excuse (proof whereof shall lie on him) fail, after having had the expenses (if any) to which he is entitled tendered to him, to comply with any summons or requisition of the Court holding a Public Inquiry or a Review Board or an Inspector holding an investigation under these regulations.



**Civil Aviation (Mortgage of Aircraft) Regulations**

*[28th June, 1996]*

1. These Regulations may be cited as the Civil Aviation (Mortgage of Aircraft) Regulations.

2. In these Regulations-

“aircraft” means an aircraft registered in the Register of Aircraft kept under article 4(1) of the Air Navigation (Overseas) Territories, Order.

“Register” means the Register of Mortgages of Aircraft kept under regulation 3(2);

“Registrar” means the Registrar of Mortgages of Aircraft under these Regulations;

3. (1) The Director General of Civil Aviation shall be the Registrar of Mortgages of Aircraft under these Regulations.

(2) The Registrar shall keep and maintain a Register of Mortgages of Aircraft.

(3) The Registrar on application made under these Regulations, shall enter in the Register-

- (a) a mortgage of aircraft and any store of spare parts for that aircraft;
- (b) a priority notice in respect of contemplated mortgages of aircraft and any store of spare parts for that aircraft;
- (c) amendment of entries in the Register;
- (d) discharge of a mortgage, and
- (e) any order made by a court in relation to a mortgage.

(4) The office of the Registrar shall be kept open for entering mortgages and for making other entries in the Register from Monday to Friday every week, other than a public holiday under the Public Holidays Act, between the hours of 8.00 am to 4.00 pm on each day.

(5) Any application delivered to the Registrar when the office remains closed shall be treated as having been received immediately after the office is next opened.

**4.** (1) An aircraft and any store of spare parts for that aircraft, in these Regulations referred to as the “mortgaged property” may be made a security for a loan or other valuable consideration and the instrument creating the security is in these Regulations called a “mortgage”.

(2) A mortgage under these Regulations shall be governed by the law designated in the mortgage as the law government the mortgage and, in the absence of such designation, shall be governed by the laws of Seychelles.

**5.** (1) An application to enter a mortgage in the Register may be made to the Registrar by or on behalf of the mortgagee in Form 1 of Schedule A.

(2) An application under subregulation (1) shall be accompanied by-

(a) copy of the mortgage certified by the applicant as a true copy; and

(b) the fee specified in Schedule B.

(3) Where a mortgage is in a language other than English, the applicant shall submit a translation thereof in the English language certified by the applicant as being, to the best of the applicant’s knowledge and belief, a true translation of the mortgage.

**6.** (1) On receipt of an application made under regulation 5, the Registrar shall enter the mortgage in the Register by making an entry of the mortgage in the Register.

(2) Mortgages shall be entered in the Register in the order in which the applications are received by the Registrar and the Registrar shall endorse and sign a memorial on each mortgage stating the date and time it was received by the Registrar.

(3) The Registrar shall notify the applicant of the date and time of the entry of the mortgage in the Register and of the registration number of the entry and shall send a copy of the notification to the mortgagor and the owner of the mortgaged property.

**7.** (1) A notice of an intention to make an application to enter a contemplated mortgage under these Regulations in the Register, in these Regulations referred to as a “priority notice”, may, on an application made by or on behalf of the prospective mortgage, be entered in the Register.

(2) An application to enter a priority notice in the Register shall be in the Form 2 of the Schedule A and shall be accompanied by the fee specified in Schedule B.

(3) On receipt of an application under this regulation, the Registrar shall enter the priority notice in the Register by making an entry of the priority notice in the Register.

(4) Priority notices shall be entered in the Register in the order in which the applications are received and the Registrar shall endorse and sign on each application a memorial stating the date and time it was received by the Registrar.

(5) The Registrar shall notify the applicant of the date and time of the entry of the priority notice in the Registrar and of the registration number in the Register and shall send a copy of the notification to the prospective mortgagor and the owner of the mortgaged property.

- 8.** (1) An application to amend any entry in the Register in relation to-
- (a) the name of the mortgagor or mortgagee;
  - (b) the address of such person; or
  - (c) the description of the mortgaged property,

may be made by on a behalf of the mortgagee in Form 3 of Schedule A.

(2) The application under subregulation (1) shall be signed by or on behalf of the mortgagor and mortgagee and shall be accompanied by the fee specified in Schedule B.

(3) On receipt of an application under this regulation the Registrar shall amend the Register accordingly and notify the mortgagee, mortgagor and the owner of the mortgaged property of such amendment.

**9.** (1) Where a mortgage entered in the Register is discharged the mortgagor shall notify the Registrar of the discharge in Form 4 in Schedule A.

(2) The notice under subregulation (1)-

- (a) shall, subject to paragraph (c), be signed by the mortgagor and mortgagee;
- (b) shall be accompanied by the mortgage with the discharge or receipt for the mortgage money endorsed thereon;
- (c) shall, where the mortgagee fails or refuses to sign the notice of discharge, be accompanied by any other documents which show, to the satisfaction of the Registrar, that the mortgage had been discharged; and
- (d) shall be accompanied by the fee specified in the Schedule B.

(3) On receipt of a notice of discharge the Registrar shall in the relevant entry in the Register in respect of the mortgage make an entry in the Register that the mortgage had been discharged by endorsing thereon the word "discharged" and the date and time of receipt of the notice and notify the mortgagor, mortgagee and the owner of the mortgaged property of such entry.

**10.** (1) Any person may on application made to the Registrar inspect any entry in the Register and the documents relating to such entry during such time as the office is kept open under regulation 3(4).

(2) The Registrar may on application made to the Registrar issue to the applicant a copy of any entry in the register and of the documents relating thereto, certified as a true copy of such entry or documents.

(3) The Registrar may on application made to the Registrar notify an applicant whether or not there are any entries in the Register relating to any aircraft and any store of spare parts for that aircraft specified in the application.

(4) An application made under subregulation (1) or (2) or (3) shall be accompanied by the fee specified in Schedule B.

(5) Any document issued under this regulation as a true copy certified by the Registrar shall be admissible in evidence at any trial to the same extent and in the same manner as the original would be admissible.

**11.** (1) Where there are more than one mortgage entered in the Register in respect of the same mortgaged property the mortgagees shall, notwithstanding any express, implied or constructive notice, be, subject to subregulation (3), entitled in priority, one over the other, according to the date and time at which each mortgage is entered in the Register and not according to the date of the mortgage itself.

(2) A mortgage entered in the Register shall not be effected by any act of bankruptcy committed by the mortgagor after the date of entry of the mortgage in the Register, notwithstanding that the mortgagor, where the mortgagor is adjudicated bankrupt, at the commencement of the bankruptcy had the mortgaged property in the possession, order or disposition of the mortgagor or was the reputed owner thereof and the mortgage shall be preferred to any right, claim or interest in the mortgaged property of other creditors of the bankrupt or any trustee or assignee on their behalf.

(3) Where a priority notice has been entered in the register under regulation 7 and the contemplated mortgage referred to therein is made and entered in the Register within 14 days thereafter, that mortgage shall be deemed to have priority from the time when the priority notice was entered on the Register.

(4) In reckoning the 14 days under subregulation (3), any day on which the office is not open under regulation 3(4), shall be excluded.

(5) Nothing in this regulation shall be construed as giving a mortgage entered in the Register any priority over any possessory lien in respect of work done on the aircraft (whether before or after the creation of the mortgage) on the express or implied authority of any person lawfully entitled to possession of the aircraft or over any right to detain the aircraft under any law.

**12.** Except as may be necessary for making the mortgaged property available as a security for the mortgage debt, the mortgagee shall not by reason of the mortgage be deemed the owner of the mortgaged property nor shall the mortgagor, if the mortgagor is the owner, be deemed to have ceased to be owner thereof.

**13.** (1) Every mortgage of a mortgage entered in the Register shall, subject to subregulations (2) and (3) have power absolutely to dispose of the mortgaged property and to give effectual receipts for the purchase money.

(2) The power conferred under subregulation (1) shall only be exercised by the leave of a court of competent jurisdiction and subject to the conditions imposed by such court.

(3) Notice of an application for leave of court shall be given to the mortgagor, all other mortgagees, if any, and the owner of the mortgaged property.

(4) Where a mortgagee has obtained the leave of a court of competent jurisdiction to exercise the powers conferred under subregulation (1), the mortgagee shall prior to the exercise of that power apply to the Registrar for entering of the order of the court in the Register.

(5) An application under subregulation (4) shall be accompanied-

- (a) by a copy of the order certified by the court to be a true copy, together with, where the order is in a language other than English, a translation of the order in the English language certified by the applicant as being, to the best of the applicant's knowledge and belief, a true translation thereof;
- (b) by an affidavit of the applicant verifying compliance with subregulation (3);
- (c) by the fees specified in Schedule B.

(6) On an application under subregulation (4), made in accordance with subregulation (5), the Registrar shall enter the order in the Register by making an endorsement in the relevant entry of the Register in relation to the mortgage.

(7) Where an order entered in the Register is an order of a court of competent jurisdiction outside Seychelles, the order shall be given effect to in Seychelles as an order of the Supreme Court of Seychelles.

(8) In this regulation "a court of competent jurisdiction" means the court designated as the court of competent jurisdiction in the mortgage and, in the absence of such designation, the Supreme Court of Seychelles.

(9) The removal of an aircraft from the Register of aircraft kept under article 4(1) of the Air Navigation (Overseas Territories) Order shall not affect the rights of any

mortgagee of a mortgaged property under these Regulations and entries shall continue to be made in the Register of Mortgages of Aircraft kept under these Regulations as if the aircraft had not been removed from the said register of aircraft.

**14.** (1) A mortgage entered in the Register may be transferred to any person and the instrument effecting the transfer shall be in Form 5 in Schedule A.

(2) On production of an instrument of transfer effected under subregulation (1) together with the fee specified in Schedule B, the Register shall record it by entering in the Register the name of the transferee as the mortgagee of the mortgaged property.

(3) The Registrar shall make an endorsement on the instrument of transfer that it has been recorded in the Register stating the day and time of the record.

**15.** (1) Where the interest of a mortgage of any mortgaged property is transmitted to any person on the death or bankruptcy of the mortgagee or by any lawful means, other than by a transfer under regulation 14, the transmission shall be authenticated by a declaration of the person to whom the interest is transmitted.

(2) A declaration under subregulation (1) shall contain a statement of the manner in which and the person to whom the interest has been transferred and shall be accompanied by an affidavit verifying to the accuracy contained in the statement.

(3) The Registrar shall, on receipt of the declaration and the affidavit together with the fee specified in Schedule B, enter the name of the person entitled to the transmission in the Register as the mortgagee of the mortgaged property.

**16.** All applications and other documents tendered to the Registrar under these Regulations shall be filed of record in the office, in such a manner as the Registrar may determine.

**17.** Any person who in an application, notice or an affidavit under these Regulations makes any statement which the person knows to be false is guilty of an offence and liable on conviction to a fine of R100,000 and to imprisonment for 5 years.

## SCHEDULE 1

FORM 1

Reg. 5

### APPLICATION FOR ENTRY OF MORTGAGE

I ..... of ..... hereby apply for the mortgage, the particulars of which are given below, to be entered in the Register of Mortgages of Aircraft.

## PARTICULARS

1. Date of Mortgage:
2. Description of the Mortgaged aircraft (including its type, nationality and registration marks and aircraft serial number) and of any store of spare parts for that aircraft (The description of the store of spare parts shall include an indication of their character and appropriate number and the place where they are stored shall be stated):
3. The sum secured by the mortgage:
4. Does the mortgage require the mortgagee to make further advances? If so, what amount :
5. Name and address of the mortgagor:
6. Registration Number of any Priority notice, if any:

Date :

Signature of applicant

-----

FORM 2

PRIORITY NOTICE

(Reg 7)

I ..... of ..... hereby give notice that I am contemplating entering into a mortgage particulars of which are given below and that if I do enter into the said mortgage, I shall apply for it to be entered in the Register of Morgages of Aircraft. I hereby apply for this notice to be entered in this Register.

PARTICULARS

1. Description of the aircraft  
which is the subject of the  
contemplated mortgage  
(including its type,  
nationality and registration  
marks and aircraft serial  
number) and any store of  
spare parts for that aircraft  
to which it is contemplated  
to extend:
2. Sum to be secured by the  
contemplated mortgage:
3. Is it contemplated that the  
mortgage will require the



mortgagee to make further  
advances? If so, of what  
amount :

4. Name and address of the  
Prospective mortgagor:

Date :

Signature of applicant

-----

FORM 3

CHANGE IN PARTICULARS (Reg 8)

We ..... hereby give notice that the particulars shown in the Register of  
Mortgages of Aircraft under registration number ..... shall be amended as  
follows :-

[State the changes]

Signature of Mortgagee

Signature of Mortgagor

Date:

-----

FORM 4

DISCHARGE OF MORTGAGE (Reg 9)

I ..... of ..... Hereby give notice that the mortgage entered in the Register of Mortgages of Aircraft under registration number ..... has been discharged.

Date

Signature of mortgagee

I agree that the aforesaid mortgage has been discharged.

Date

Signature of mortgagee

-----

FORM 5

TRANSFER OF MORTGAGE

(Reg 14)

[To be endorsed on the original mortgage]

I ..... of ..... in consideration of ..... paid to me by ..... Hereby transfer to ..... the benefit of this mortgage.

Date

Signature of mortgagee

-----

SCHEDULE B

FEES

1. Application under regulation 5 \$500 for entry of each

	mortgage	
2.	Application under regulation 7	\$300 for entry of each priority notice
3.	Application under regulation 8	\$100 for each application
4.	Notice under regulation 9	\$100 for each notice of discharge
5.	Application under regulation 10-	
	(a) under subregulation (1)	\$200 for each application
	(b) under subregulation (2)	\$100 for each copy
	(c) under subregulation (3)	\$ 50 for each copy
6.	Application under regulation 13(5)	\$100 for each order
7.	Record of transfer of mortgage under regulation 14	\$100 for each transfer
8.	Record of transmission of an interest under regulation 15	\$100 for each transmission

In this Schedule the symbol \$ denotes dollars in the currency of United States of America.

---

Section 3(1)

**Civil Aviation (Civil Aviation Directives) Regulations**

S.I. 56 of 2005

*[19th December, 2005]*

1. These Regulations may be cited as the Civil Aviation (Civil Aviation Directives) Regulations.

2. In these Regulations-

“Authority” means the Seychelles Civil Aviation Authority established by section 3 of the Seychelles Civil Aviation Authority Act, 2005;

“international aviation standard” means any international standard or recommended practice or procedure consistent with article 37 of the International Civil Aviation Organisation Convention;

“national aviation standard” means any national standard or recommended practice or procedure consistent with article 37 of the International Civil Aviation Organisation Convention.

**3.** The Authority may, by the publication of civil aviation directives or otherwise prescribe conditions and technical standards relating to any national aviation standard or international aviation standard, not by stating the text thereof but by making reference to the number, title and year of issue of that aviation standard, or to any other particulars by which that aviation standard is sufficiently identified.

**4.** If any national aviation standard or international aviation standard referred to in a civil aviation directive is at any time after the incorporation thereof in the civil aviation directive amended or substituted, it shall be deemed to be a reference to that aviation standard as so amended or substituted, as the case may be, unless the contrary is expressly stated in the civil aviation directive.

---

## **Civil Aviation Regulations**

*[3<sup>rd</sup> September, 2007]*

S.I. 51 of 2000  
S.I. 18 of 2005  
S.I. 55 of 2005  
S.I. 23 of 2007

- 1.** These Regulations may be cited as the Civil Aviation Regulations.
- 2.** Notwithstanding anything to the contrary in the Air Navigation (Overseas Territories) Order, any power conferred on the Minister by that Order, other than the power to make regulations, may be exercised by -
  - (a) the Chief Executive Officer;
  - (b) the General Manager, Safety Regulation;
  - (c) the Deputy General Manager, Safety Regulation;
  - (d) the Head Flight Operations;
  - (e) Head Airworthiness;
  - (f) Senior Personnel Licensing Officer;
  - (g) Head Aerodrome Safety; or
  - (h) Head Air Traffic Standards.

**3.** Any power referred to in regulation 2 exercised at any time in accordance with that regulation shall be lawful.

**4.** The Civil Aviation (Amendment) Regulations, 2005 is hereby repealed.

---